



# BEZ **Generation "D"** Condensing Units

## PRODUCT DATA & SPECIFICATIONS

Part # 1108863

**PRODUCT SUPPORT**  
 web: [www.b-rp.ca/bez](http://www.b-rp.ca/bez)  
 email: [smcu@b-rp.ca](mailto:smcu@b-rp.ca)  
 call: 1-844-893-3222 x521

scan: 

**60**  
Hz

Indoor/Outdoor Air-Cooled  
Scroll Condensing Units

3/4 to 17 HP -  
High and Low  
Temperature Refrigeration



INCLUDES MODELS FOR DOE & NRCAN  
**AWEF-COMPLIANT APPLICATIONS**

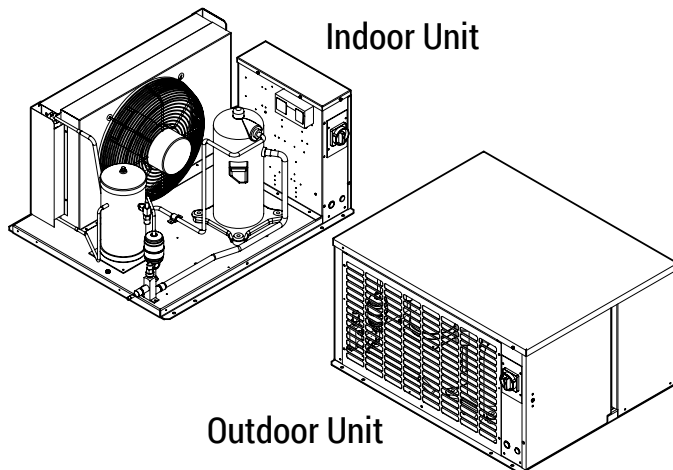

**SMARTSPEED™**

FAN MOTOR TECHNOLOGY

See Page 4 for details

**LIMITROL+**

FLOATING HEAD PRESSURE CONTROL SYSTEM

See Page 5 for details

## CONTENTS

	Page
Nomenclature.....	2
Features, Options and Pre-Selected Option Packages.....	2 - 3
<b>SMARTSPEED™</b> Fan Motor Technology .....	4
<b>LIMITROL+</b> Floating Head Pressure Control System.....	5
Selection Capacity Data.....	6 - 18
Electrical Data.....	19 - 22
Annual Walk-In Energy Factor (AWEF) Ratings.....	23 - 24
Dimensional Data.....	25 - 29
Specifications.....	30
Wiring Diagrams.....	31 - 34
Wiring Diagrams - Models with <b>SMARTSPEED™</b> .....	35 - 36
Product Support Resources.....	BACK

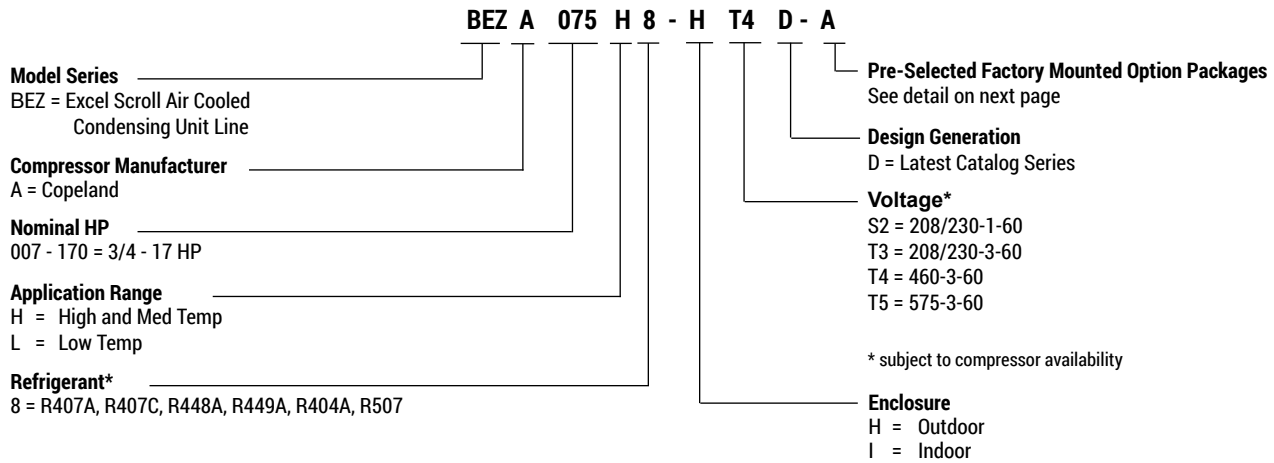

**STANDARD FEATURES**

*Indoor Unit:*

- Compatible with Low GWP Refrigerants
- Weatherproof electrical control box with compressor contactor and fused control circuit
- Copeland scroll compressor
- High efficiency enhanced tube and fin condenser design
- SmartSpeed EC Fan Motor Technology standard on models using chassis 1 (see page 35)
- Energy efficient PSC condenser fan motor on models using chassis 2 thru 6 (see page 35)
- Receiver with fusible plug and liquid shut off valve
- Suction service valve
- Pre-formed copper tubing
- Liquid injection (low temp. models)
- Unit leak tested and shipped with helium holding charge

- Fixed high pressure switch and adjustable low pressure control
- Receiver inlet valve on 2-fan units models only
- Discharge thermostat on applicable models only
- Painted cabinet
- Time delay relay for compressor

*Outdoor Unit: All Standard Features of Indoor Unit, Plus:*



- Painted weather-resistant housing with removable hood
- Flooded head pressure control (adjustable)
- Crankcase heater
- Fan cycling control with flex hose (2 fan units)

**AVAILABLE OPTIONS**

- Suction accumulator with and without boil-out coil
- Discharge line check valve
- Oil separator with and without oil return filter and solenoid valve
- Receiver inlet ball valve
- Heated and Insulated receiver
- Over-sized receiver
- Sealed liquid line filter drier & sight-glass
- Ball valve - liquid line (shipped loose)
- Insulated suction lines
- Leg kits
- Discharge air hood
- Sub cooling circuit on 5 - 17 HP models
- Liquid line solenoid valve (with standard 230 volt coil) - shipped loose
- Variable speed EC motors as head pressure control (see Bulletin B40-HPC-AG or <https://docs.b-rp.ca/1101112.pdf> for details)
- QuickVac Evacuation and Refrigerant Recovery Valves
- Dual pressure control with flex hoses
- Compressor circuit breaker
- Current sensing relay - for use with oil safety control (where applicable)
- Defrost heater contactor c/w fuse block
- Evaporator fan contactor c/w fuse block
- Disconnect switch
- Disconnect fusing
- Pump down toggle switch
- Lock out control circuit relay
- Mechanical time clock
- Electronic voltage / Phase monitor
- **SmartSpeed Fan Motor Technology on models using chassis 2-6 (see page 4)**
- **Limitrol+ Floating Head Pressure Control System (see page 5 or Bulletin B40-LIMITROL-AG or [docs.b-rp.ca/1101115.pdf](https://docs.b-rp.ca/1101115.pdf) for details)**

**PRE-SELECTED FACTORY MOUNTED OPTION PACKAGES**

**BEZ - SCROLL CONDENSING UNITS**

	For High / Moderate Ambients	For Moderate / Low Ambients
<b>GOOD</b> 	<b>Package B:</b> + Liquid Line Filter Drier <sup>1</sup> & Sight Glass	<b>Package D:</b> + Liquid Line Filter Drier <sup>1</sup> & Sight Glass + Heated and Insulated Receiver
<b>BETTER</b> 	<b>Package N:</b> + Liquid Line Filter Drier <sup>1</sup> & Sight Glass + Suction Accumulator w/o Heat Exchanger	<b>Package J:</b> + Liquid Line Filter Drier <sup>1</sup> & Sight Glass + Suction Accumulator w/o Heat Exchanger + Heated and Insulated Receiver
<b>BEST</b> 	<b>Package P:</b> + Liquid Line Filter Drier <sup>1</sup> & Sight Glass + Suction Accumulator w/o Heat Exchanger + Suction Filter <sup>2</sup> + Non-Fused Disconnect	<b>Package Q:</b> + Liquid Line Filter Drier <sup>1</sup> & Sight Glass + Suction Accumulator w/o Heat Exchanger + Suction Filter <sup>2</sup> + Non-Fused Disconnect + Heated and Insulated Receiver

<sup>1</sup> Liquid Line Filter Drier: Sealed on ALL One Fan Model Units, Replaceable on ALL Two Fan Model Units.

<sup>2</sup> Suction Filter: Sealed on ALL One Fan Model Units, Replaceable on ALL Two Fan Model Units.

**For information on Evaporator Defrost Kits and Fuse Packages, visit [www.b-rp.ca/dfk](http://www.b-rp.ca/dfk)**

**RECOMMENDATIONS FOR SELECTING FACTORY MOUNTED OPTION PACKAGES**

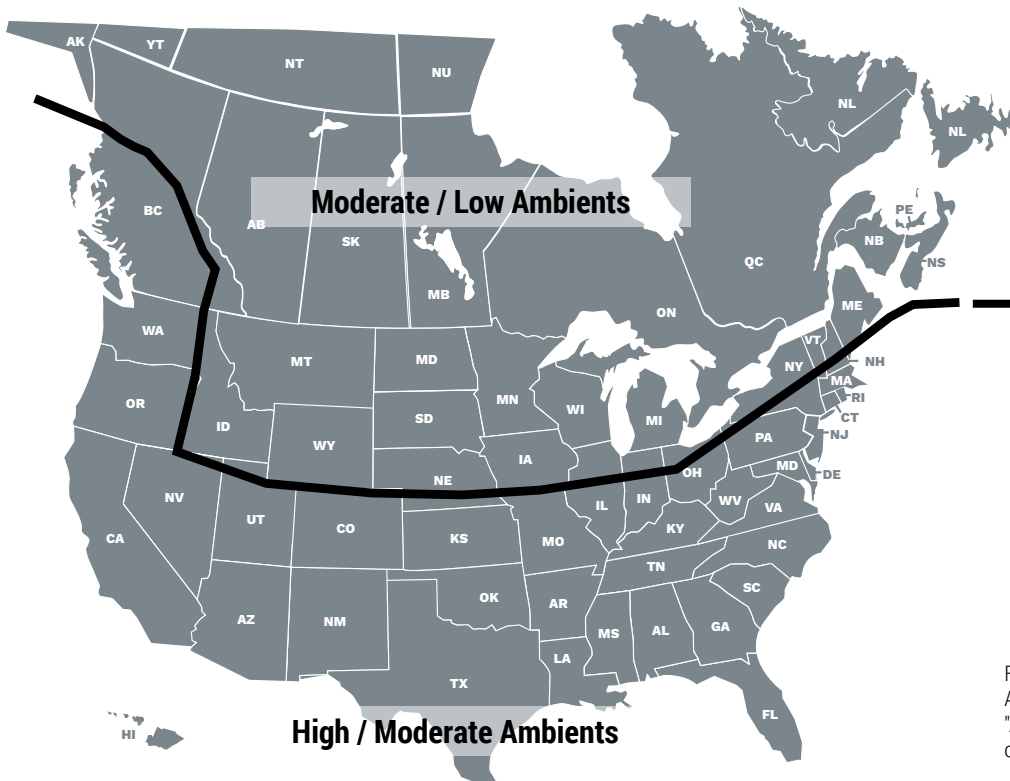

**For Moderate / Low Ambients:**  
 Good: Package D  
 Better: Package J  
 Best: Package Q

**For High / Moderate Ambients:**  
 Good: Package B  
 Better: Package N  
 Best: Package P

For further details, visit our website and see Application Bulletin BAB-0101-02-1: "About Heated And Insulated Receivers" or contact your local sales representative.

**US Patent No.  
9,297,567**

# SMARTSPEED™

FAN MOTOR TECHNOLOGY



## DESIGN FEATURES

- Standard on models using chassis 1 (optional on chassis 2 thru 6)
- No special controls required. No worries about wind or cold climates.
- Ambients above 55°F - EC motor operates at full speed, crankcase heater and heated + insulated receiver disabled from control circuit
- Ambients below 55°F - EC motor operates at low speed, crankcase heater and heated + insulated receiver enabled from control circuit

**Condensing Unit EER - Standard Unit vs. SmartSpeed**

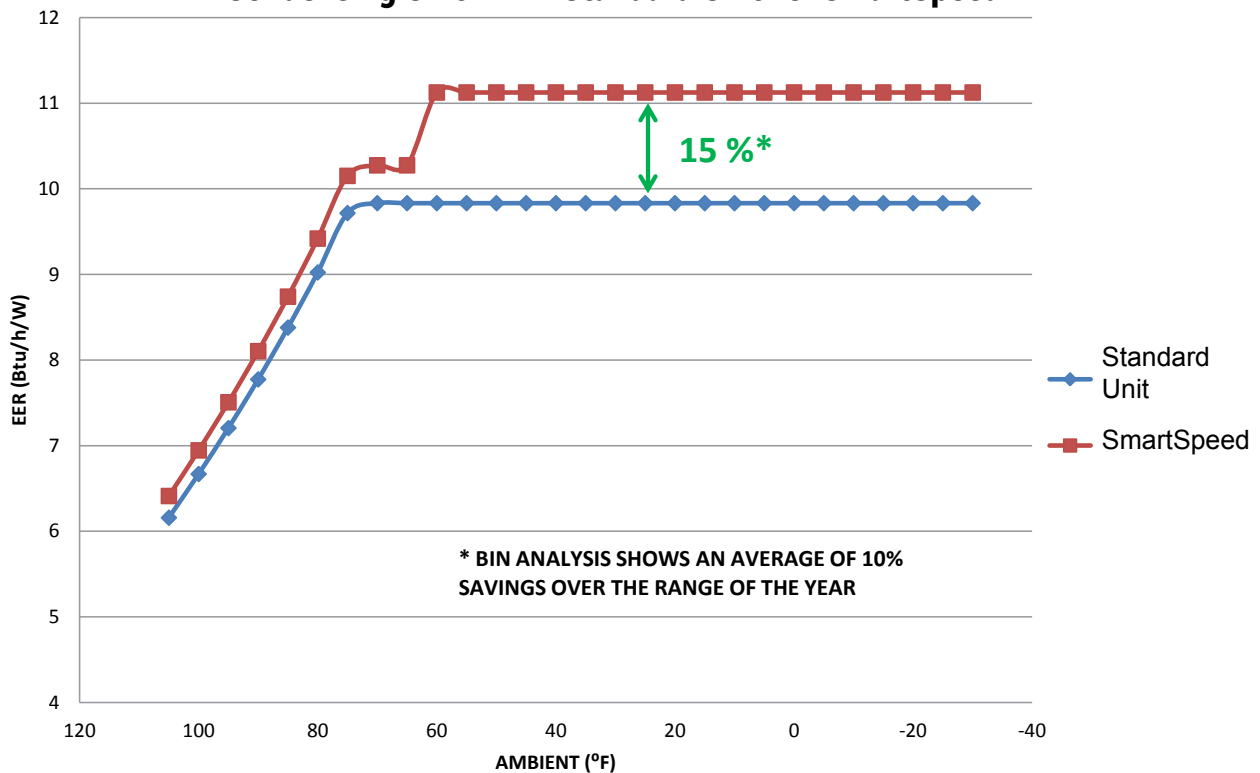

**Refer to  
Pages 35-36  
For Wiring Details**

Condensing Unit with SmartSpeed Power Consumption Per Motor		
Chassis Size (see pages 31-35)	Ambients above 55°F. Fan Full Speed. Crankcase and Receiver Heaters Off.	Ambients below 55°F. Fan Low Speed. Crankcase and Receiver Heaters On.
1	102 W	19 W
2	168 W	37 W
3,4	362 W	76 W
5	630 W	152 W
6	1180 W	240 W

# LIMITROL

FLOATING HEAD PRESSURE CONTROL SYSTEM

- **Reduces compressor energy consumption and run time**
- **EC motor technology further saves energy and reduces electrical requirements**
- **Lowered environmental impact through reduced refrigerant use**
- **Stable system performance in lower ambients**

**What is Limitrol+?** Limitrol+ combines various technologies into a responsive system that floats head pressure, saving energy and reduces environmental impact.

Unlike competitive systems, Limitrol+ combines variable speed EC motor technology, condenser portioning and various systems modifications to provide the ultimate in performance and control.

As a result, Limitrol+ functions in much colder ambients where previous systems have proven ineffective.

**What does it do?** Conventional head pressure control systems maintain a constant head pressure regardless of ambient temperatures. Limitrol+ intelligently responds to ambient conditions to float head pressure without sacrificing system performance at lower temperatures.

**What are its applications?**

- Condensing units over 5 HP
- Ideally suited and most effective in applications with fluctuating ambients
- Perfect for installations where reduced refrigerant charges are desired or required.

**How much can Limitrol+ save you?**

MODEL	Philadelphia, PA		New York, NY		Boston, MA		Charlotte, NC		Atlanta, GA		Los Angeles, CA		St Louis, MO		St. Paul, MN		Toronto, ON	
	%	\$	%	\$	%	\$	%	\$	%	\$	%	\$	%	\$	%	\$	%	\$
<b>5 HP Cooler</b>	22	616	23	1,099	25	1,081	18	474	16	521	16	835	20	624	25	798	27	638
<b>7.5 HP Cooler</b>	21	1,008	22	1,805	23	1,707	18	843	17	954	17	1,499	19	1,053	24	1,270	25	1,000
<b>10 HP Cooler</b>	18	1,204	18	2,131	20	2,095	15	975	14	1,089	18	2,446	16	1,227	20	1,529	21	1,223
<b>15 HP Cooler</b>	19	1,852	20	3,300	21	3,170	16	1,567	15	1,767	19	3,570	17	1,916	22	2,337	22	1,834
<b>6 HP Freezer</b>	24	903	25	1,621	26	1,548	21	753	20	848	23	1,548	22	928	26	1,119	27	891
<b>7.5 HP Freezer</b>	21	994	21	1,783	23	1,726	17	800	16	891	18	1,591	19	1,012	23	1,255	24	1,004
<b>13 HP Freezer</b>	19	1,425	19	2,535	21	2,450	16	1,150	15	1,286	15	2,110	17	1,471	21	1,798	22	1,428
<b>15 HP Freezer</b>	18	1,602	19	2,846	20	2,717	16	1,312	15	1,479	14	2,224	17	1,672	20	2,009	21	1,587

\* The above is a BIN Hour Analysis. Weather data was used from ASHRAE Weather Data Viewer and electrical rates for each city are based on June 2013 data from EIA (U.S. Energy Information Administration).

\*\* Above numbers do not include refrigerant savings, and further cost savings can be expected.

For more information on Limitrol+ Floating Head Pressure Control System visit [b-rp.ca/limitrol](http://b-rp.ca/limitrol) or see Bulletin B40-LIMITROL-AG (<https://docs.b-rp.ca/1101115.pdf>)

For more information on Head Pressure Control, please refer to our “Head Pressure Control Application Guide” Bulletin B40-HPC-AG (<https://docs.b-rp.ca/1101112.pdf>)

# SELECTION CAPACITY DATA

# BEZ - SCROLL CONDENSING UNITS

## R404A R507 High Temperature

Model BEZA	Saturated Suction Temp.		Selection Capacity BTU/h					
			Ambient Temperature					
	°F	°C	85°F (29.4°C)	90°F (32.2°C)	95°F (35°C)	100°F (37.8°C)	105°F (40.6°C)	110°F (43.3°C)
BEZA007H8  Compressor Model ZB06KAE / YB06KAE	40	4.4	10400	9970	9510	9050	8580	8120
	35	1.7	9600	9190	8780	8360	7940	7520
	30	-1.1	8790	8430	8060	7680	7310	6920
	25	-3.9	8010	7690	7360	7020	6690	6340
	20	-6.7	7270	6980	6690	6390	6080	5770
	15	-9.4	6570	6310	6050	5780	5510	5220
	10	-12.2	5910	5680	5450	5200	4950	4700
	5	-15.0	5300	5100	4890	4660	4440	4200
	0	-17.8	4750	4570	4370	4170	3950	3730
	BEZA008H8  Compressor Model ZB07KAE / YB07KAE	40	4.4	12600	12000	11400	10900	10300
35		1.7	11500	11000	10500	10000	9480	8950
30		-1.1	10500	10100	9630	9170	8710	8250
25		-3.9	9580	9190	8790	8390	7990	7580
20		-6.7	8690	8350	8000	7650	7300	6940
15		-9.4	7860	7560	7260	6950	6640	6330
10		-12.2	7080	6820	6560	6290	6020	5750
5		-15.0	6350	6120	5890	5660	5430	5190
0		-17.8	5660	5460	5260	5050	4850	4640
BEZA009H8  Compressor Model ZB08KAE / YB08KAE		40	4.4	14000	13400	12800	12100	11500
	35	1.7	12800	12200	11700	11100	10500	9930
	30	-1.1	11700	11200	10700	10200	9650	9130
	25	-3.9	10700	10200	9780	9320	8860	8390
	20	-6.7	9760	9360	8950	8540	8130	7720
	15	-9.4	8900	8540	8180	7820	7460	7100
	10	-12.2	8090	7780	7470	7150	6830	6510
	5	-15.0	7340	7060	6780	6510	6230	5940
	0	-17.8	6610	6370	6120	5880	5630	5380
	BEZA010H8  Compressor Model ZS09KAE / YS09KAE	40	4.4	16500	15700	15000	14300	13600
35		1.7	15200	14500	13900	13300	12700	12100
30		-1.1	14000	13400	12800	12200	11700	11200
25		-3.9	12800	12300	11800	11300	10800	10400
20		-6.7	11800	11300	10800	10300	9920	9540
15		-9.4	10700	10300	9860	9450	9080	8740
10		-12.2	9730	9340	8960	8590	8260	7960
5		-15.0	8800	8440	8090	7760	7460	7200
0		-17.8	7920	7590	7260	6960	6680	6440
BEZA011H8  Compressor Model ZS11KAE / YS11KAE		40	4.4	18700	17900	17100	16300	15500
	35	1.7	17300	16600	15800	15100	14400	13800
	30	-1.1	16000	15300	14600	14000	13400	12800
	25	-3.9	14700	14100	13500	12900	12400	11900
	20	-6.7	13500	12900	12400	11900	11400	11000
	15	-9.4	12300	11800	11300	10900	10400	10100
	10	-12.2	11200	10700	10300	9890	9520	9200
	5	-15.0	10100	9720	9320	8950	8610	8330
	0	-17.8	9130	8750	8380	8030	7720	7460
	BEZA015H8  Compressor Model ZS13KAE / YS12KAE	40	4.4	21200	20200	19300	18500	17700
35		1.7	19800	19000	18200	17400	16700	16000
30		-1.1	18500	17700	17000	16300	15700	15200
25		-3.9	17200	16500	15900	15300	14800	14300
20		-6.7	15900	15300	14800	14200	13800	13400
15		-9.4	14700	14200	13700	13200	12800	12500
10		-12.2	13500	13000	12600	12200	11900	11600
5		-15.0	12300	11900	11500	11200	10900	10700
0		-17.8	11200	10800	10500	10100	9880	9700
BEZA020H8  Compressor Model ZS15KAE / YS14KA		40	4.4	24500	23400	22400	21400	20500
	35	1.7	23000	22000	21100	20300	19500	18800
	30	-1.1	21500	20700	19900	19100	18500	17900
	25	-3.9	20100	19300	18600	18000	17400	17000
	20	-6.7	18700	18000	17400	16800	16400	16000
	15	-9.4	17300	16700	16200	15700	15300	15000
	10	-12.2	16000	15400	14900	14500	14200	14000
	5	-15.0	14600	14100	13700	13300	13100	12900
	0	-17.8	13300	12800	12500	12100	11900	11700

table continues in next column >>>

Model BEZA	Saturated Suction Temp.		Selection Capacity BTU/h					
			Ambient Temperature					
	°F	°C	85°F (29.4°C)	90°F (32.2°C)	95°F (35°C)	100°F (37.8°C)	105°F (40.6°C)	110°F (43.3°C)
BEZA025H8  Compressor Model ZS19KAE / YS16KAE	40	4.4	31300	29900	28500	27200	25900	24600
	35	1.7	28800	27500	26300	25100	23900	22800
	30	-1.1	26400	25300	24200	23100	22100	21100
	25	-3.9	24200	23200	22200	21200	20300	19500
	20	-6.7	22100	21200	20300	19400	18600	17900
	15	-9.4	20100	19300	18500	17700	17000	16400
	10	-12.2	18200	17500	16800	16100	15400	14900
	5	-15.0	16500	15800	15100	14500	13900	13400
	0	-17.8	14800	14200	13600	13000	12500	12000
	BEZA030H8  Compressor Model ZS21KAE / YS21KAE	40	4.4	39800	38000	36200	34600	32900
35		1.7	36800	35100	33600	32000	30600	29300
30		-1.1	33900	32400	31000	29600	28400	27200
25		-3.9	31100	29800	28500	27300	26200	25200
20		-6.7	28500	27300	26200	25100	24100	23200
15		-9.4	26000	25000	23900	23000	22100	21300
10		-12.2	23600	22700	21800	20900	20100	19400
5		-15.0	21400	20500	19700	18900	18200	17600
0		-17.8	19200	18400	17700	16900	16300	15700
BEZA035H8  Compressor Model ZS26KAE / YS24KAE		40	4.4	43400	41500	39600	37800	36000
	35	1.7	40200	38400	36700	35100	33500	32100
	30	-1.1	37100	35500	34000	32500	31100	29900
	25	-3.9	34200	32700	31300	30000	28800	27700
	20	-6.7	31300	30100	28800	27600	26600	25600
	15	-9.4	28700	27500	26400	25300	24400	23500
	10	-12.2	26100	25000	24000	23100	22200	21500
	5	-15.0	23600	22700	21700	20900	20100	19500
	0	-17.8	21300	20400	19500	18700	18000	17400
	BEZA040H8  Compressor Model ZS29KAE / YS26KAE	40	4.4	50200	47900	45700	43600	41600
35		1.7	46400	44400	42400	40500	38700	37000
30		-1.1	42800	40900	39100	37400	35800	34400
25		-3.9	39300	37700	36100	34500	33100	31800
20		-6.7	36000	34600	33100	31800	30500	29400
15		-9.4	32900	31600	30300	29100	28000	27000
10		-12.2	29900	28700	27600	26500	25500	24600
5		-15.0	27100	26000	24900	23900	23000	22300
0		-17.8	24400	23400	22400	21500	20600	19900
BEZA045H8  Compressor Model ZS33KAE / YS30KAE		40	4.4	54200	51700	49400	47100	44900
	35	1.7	50100	47900	45800	43800	41800	40100
	30	-1.1	46300	44300	42400	40600	38900	37300
	25	-3.9	42600	40800	39100	37500	36000	34600
	20	-6.7	39100	37500	36000	34500	33200	32000
	15	-9.4	35800	34300	32900	31600	30400	29400
	10	-12.2	32600	31300	30000	28800	27800	26900
	5	-15.0	29500	28300	27200	26100	25100	24300
	0	-17.8	26600	25500	24400	23400	22500	21800
	BEZA050H8  Compressor Model ZB38KCE / YB34KAE	40	4.4	60300	57600	54900	52100	49300
35		1.7	55900	53400	50900	48300	45700	43000
30		-1.1	51700	49400	47100	44700	42200	39700
25		-3.9	47700	45600	43400	41200	38900	36600
20		-6.7	43800	41900	39900	37900	35800	33600
15		-9.4	40200	38400	36600	34700	32800	30800
10		-12.2	36700	35000	33400	31700	29900	28100
5		-15.0	33400	31900	30400	28800	27200	25500
0		-17.8	30200	28900	27500	26100	24600	23100
BEZA060H8  Compressor Model ZB45KCE / YB40KAE		40	4.4	72100	68900	65700	62400	59100
	35	1.7	66900	63900	60900	57900	54800	51600
	30	-1.1	61900	59100	56400	53500	50600	47700
	25	-3.9	57000	54500	52000	49300	46700	43900
	20	-6.7	52400	50100	47800	45300	42900	40400
	15	-9.4	48000	45900	43700	41500	39300	36900
	10	-12.2	43800	41900	39900	37900	35800	33700
	5	-15.0	39800	38100	36300	34500	32600	30600
	0	-17.8	36100	34500	32900	31200	29500	27700

table continues on next page >>>

**SELECTION CAPACITY DATA**

**BEZ - SCROLL CONDENSING UNITS**

**R404A R507 High Temperature (cont'd)**

Model BEZA	Saturated Suction Temp.		Selection Capacity BTU/h						Ambient Temperature	
	° F	° C	85°F	90°F	95°F	100°F	105°F	110°F	° F	° C
			(29.4°C)	(32.2°C)	(35°C)	(37.8°C)	(40.6°C)	(43.3°C)		
BEZA061H8  Compressor Model ZB48KCE / YB44KAE	40	4.4	79200	75600	72000	68300	64600	60800		
	35	1.7	73600	70300	66900	63500	60000	56400		
	30	-1.1	68200	65100	62000	58800	55500	52200		
	25	-3.9	63000	60200	57300	54300	51300	48200		
	20	-6.7	58000	55400	52700	50000	47200	44300		
	15	-9.4	53200	50800	48400	45900	43300	40600		
	10	-12.2	48700	46500	44200	41900	39500	37100		
	5	-15.0	44300	42300	40300	38200	36000	33700		
	0	-17.8	40200	38400	36500	34600	32600	30500		
	BEZA070H8  Compressor Model ZB57KCE / YB50KAE	40	4.4	96000	91900	87700	83500	79100	74500	
35		1.7	88800	85100	81300	77400	73300	69200		
30		-1.1	81900	78500	75100	71500	67800	64000		
25		-3.9	75300	72300	69200	65900	62600	59100		
20		-6.7	69100	66400	63500	60600	57600	54500		
15		-9.4	63200	60700	58200	55600	52900	50000		
10		-12.2	57600	55400	53100	50800	48300	45800		
5		-15.0	52300	50300	48300	46200	44000	41800		
0		-17.8	47300	45600	43700	41900	40000	37900		
BEZA076H8  Compressor Model ZB66K5E / YB56KAE		40	4.4	110000	105000	100000	95300	90200	85000	
	35	1.7	102000	97700	93100	88500	83700	78900		
	30	-1.1	94600	90400	86200	81900	77600	73100		
	25	-3.9	87200	83400	79600	75600	71600	67600		
	20	-6.7	80200	76700	73200	69600	66000	62200		
	15	-9.4	73500	70300	67100	63900	60500	57100		
	10	-12.2	67100	64200	61300	58400	55300	52200		
	5	-15.0	61000	58400	55800	53100	50300	47400		
	0	-17.8	55200	52900	50500	48000	45400	42800		
	BEZA085H8  Compressor Model ZB76K5E / YB68KAE	40	4.4	123000	118000	112000	106000	101000	94900	
35		1.7	114000	109000	104000	98900	93600	88300		
30		-1.1	106000	101000	96500	91800	86900	82000		
25		-3.9	97900	93600	89300	84900	80500	76100		
20		-6.7	90200	86300	82400	78400	74400	70400		
15		-9.4	82800	79300	75800	72200	68600	65000		
10		-12.2	75800	72700	69500	66300	63100	59800		
5		-15.0	69100	66300	63500	60600	57800	54900		
0		-17.8	62700	60200	57700	55200	52700	50100		
BEZA110H8  Compressor Model ZB95K5E / YB83KAE		40	4.4	163000	156000	148000	141000	134000	126000	
	35	1.7	151000	144000	138000	131000	124000	117000		
	30	-1.1	139000	133000	127000	121000	115000	108000		
	25	-3.9	128000	123000	117000	111000	106000	99500		
	20	-6.7	118000	113000	108000	102000	96800	91200		
	15	-9.4	108000	103000	98400	93500	88500	83200		
	10	-12.2	98100	93900	89500	85000	80400	75500		
	5	-15.0	88900	85100	81000	76900	72500	67900		
	0	-17.8	80200	76600	72800	68900	64800	60500		
	BEZA150H8  Compressor Model ZB114K5E / YB100KAE	40	4.4	187000	178000	170000	161000	153000	144000	
35		1.7	173000	166000	158000	150000	142000	133000		
30		-1.1	160000	153000	146000	139000	131000	123000		
25		-3.9	148000	142000	135000	128000	121000	114000		
20		-6.7	136000	130000	124000	118000	111000	104000		
15		-9.4	125000	119000	113000	107000	101000	95100		
10		-12.2	114000	109000	103000	97800	92200	86300		
5		-15.0	103000	98400	93500	88500	83200	77800		
0		-17.8	93000	88700	84200	79500	74600	69500		

**SELECTION CAPACITY DATA**

**BEZ - SCROLL CONDENSING UNITS**

**R407A High Temperature**

Model BEZA	Saturated Suction Temp.		Selection Capacity BTU/h						Ambient Temperature					
	°F	°C	85°F	90°F	95°F	100°F	105°F	110°F	85°F	90°F	95°F	100°F	105°F	110°F
			(29.4°C)	(32.2°C)	(35°C)	(37.8°C)	(40.6°C)	(43.3°C)	(29.4°C)	(32.2°C)	(35°C)	(37.8°C)	(40.6°C)	(43.3°C)
BEZA007H8  Compressor Model ZB06KAE / YB06KAE	40	4.4	10200	9790	9430	9070	8700	8340	30600	29500	28500	27500	26400	25300
	35	1.7	9200	8880	8560	8230	7890	7570	27800	26800	25900	25000	24000	23000
	30	-1.1	8310	8020	7730	7440	7140	6840	25300	24400	23500	22700	21700	20900
	25	-3.9	7480	7220	6960	6700	6440	6170	23000	22200	21400	20600	19800	18900
	20	-6.7	6710	6480	6240	6010	5770	5540	20800	20100	19400	18700	17900	17200
	15	-9.4	6000	5790	5580	5380	5170	4960	18800	18200	17600	17000	16200	15600
	10	-12.2	5360	5180	4990	4820	4630	4440	17100	16500	15900	15300	14700	14100
	5	-15.0	4780	4620	4460	4310	4140	3980	15400	14900	14400	13800	13300	12800
	0	-17.8	4270	4140	3990	3860	3710	3570	13800	13400	12900	12500	12000	11400
BEZA008H8  Compressor Model ZB07KAE / YB07KAE	40	4.4	11800	11400	11000	10600	10300	9900	39100	37800	36400	34900	33600	32100
	35	1.7	10800	10500	10200	9800	9450	9100	35700	34400	33200	31900	30600	29300
	30	-1.1	9930	9610	9290	8960	8640	8320	32400	31300	30200	29000	27900	26700
	25	-3.9	9040	8740	8440	8140	7840	7540	29500	28500	27500	26400	25400	24300
	20	-6.7	8170	7900	7620	7340	7050	6770	26800	25900	25000	24000	23100	22000
	15	-9.4	7350	7090	6830	6560	6290	6010	24300	23500	22700	21800	20900	20100
	10	-12.2	6560	6320	6070	5810	5540	5270	22000	21300	20600	19800	19000	18200
	5	-15.0	5820	5600	5350	5100	4830	4540	20000	19200	18600	17900	17200	16500
	0	-17.8	5130	4900	4660	4400	4140	3850	18000	17400	16700	16100	15500	14900
BEZA009H8  Compressor Model ZB08KAE / YB08KAE	40	4.4	13200	12700	12300	11900	11300	10900	43300	41700	40100	38600	37000	35400
	35	1.7	12300	11900	11400	10900	10500	10100	39500	38100	36700	35300	33800	32300
	30	-1.1	11300	10900	10500	10100	9720	9310	36000	34700	33500	32100	30900	29500
	25	-3.9	10400	10000	9670	9300	8920	8550	32700	31500	30400	29200	28000	26800
	20	-6.7	9480	9160	8830	8490	8140	7800	29500	28500	27600	26500	25400	24200
	15	-9.4	8610	8310	8010	7700	7380	7060	26600	25800	24900	23900	22900	21900
	10	-12.2	7750	7480	7200	6920	6640	6350	23900	23200	22400	21500	20600	19800
	5	-15.0	6910	6660	6410	6160	5910	5660	21400	20800	20000	19200	18500	17700
	0	-17.8	6080	5870	5650	5420	5200	4980	19100	18500	17900	17200	16500	15700
BEZA010H8  Compressor Model ZS09KAE / YS09KAE	40	4.4	16300	15800	15300	14700	14100	13500	48800	47100	45300	43700	41900	40100
	35	1.7	14900	14500	13900	13400	12900	12300	44500	43000	41400	39700	38200	36600
	30	-1.1	13500	13100	12700	12200	11600	11200	40500	39100	37600	36200	34700	33300
	25	-3.9	12400	12000	11500	11000	10600	10200	36800	35600	34200	33000	31600	30300
	20	-6.7	11200	10800	10400	10000	9650	9260	33500	32300	31100	30000	28700	27600
	15	-9.4	10200	9820	9460	9110	8760	8390	30400	29300	28300	27100	26100	25000
	10	-12.2	9190	8890	8570	8260	7940	7610	27600	26500	25600	24600	23600	22700
	5	-15.0	8310	8030	7750	7460	7180	6880	24900	24000	23200	22300	21400	20500
	0	-17.8	7480	7230	6980	6720	6460	6210	22400	21600	20900	20100	19200	18500
BEZA011H8  Compressor Model ZS11KAE / YS11KAE	40	4.4	19100	18400	17800	17100	16400	15700	54400	52500	50500	48600	46600	44600
	35	1.7	17500	16800	16200	15600	15000	14400	49600	47900	46100	44300	42500	40700
	30	-1.1	15900	15300	14800	14200	13600	13100	45200	43700	42000	40400	38700	37000
	25	-3.9	14500	13900	13400	12900	12400	11900	41200	39700	38300	36800	35300	33800
	20	-6.7	13100	12700	12300	11800	11300	10800	37500	36200	34800	33500	32100	30800
	15	-9.4	12000	11500	11100	10700	10300	9840	34100	32900	31600	30500	29200	28000
	10	-12.2	10800	10500	10100	9700	9320	8930	30900	29800	28700	27600	26500	25400
	5	-15.0	9800	9460	9120	8780	8430	8090	28000	26900	26000	25000	24000	23000
	0	-17.8	8830	8530	8230	7910	7610	7300	25200	24300	23400	22600	21600	20800
BEZA015H8  Compressor Model ZS13KAE / YS12KAE	40	4.4	21300	20600	19800	19000	18200	17500	63200	60800	58300	55800	53200	-
	35	1.7	19400	18800	18100	17400	16600	15900	57900	55700	53500	51200	48800	-
	30	-1.1	17800	17200	16500	15900	15200	14600	52800	50900	48800	46600	44400	42200
	25	-3.9	16200	15600	15100	14500	13800	13300	47900	46200	44200	42300	40400	38300
	20	-6.7	14800	14200	13700	13200	12700	12100	43400	41700	39900	38200	36400	34500
	15	-9.4	13400	13000	12500	12000	11500	11000	39000	37400	35900	34300	32700	31100
	10	-12.2	12200	11800	11300	10900	10500	10000	34800	33500	32000	30600	29200	27800
	5	-15.0	11000	10600	10300	9880	9480	9100	31000	29700	28500	27200	26000	24800
	0	-17.8	9950	9610	9270	8910	8570	8230	27500	26300	25200	24000	23000	21900
BEZA020H8  Compressor Model ZS15KAE / YS14KAE	40	4.4	25200	24200	23300	22400	21400	-	72300	69600	66800	63900	60900	57900
	35	1.7	23000	22200	21300	20500	19600	18700	66200	63800	61200	58400	55700	53000
	30	-1.1	21000	20300	19400	18700	17900	17100	60400	58100	55700	53400	50900	48300
	25	-3.9	19100	18400	17800	17100	16300	15600	54900	52700	50500	48400	46100	43800
	20	-6.7	17400	16700	16100	15400	14800	14100	49600	47600	45700	43600	41500	39400
	15	-9.4	15700	15100	14600	13900	13300	12800	44500	42700	41000	39100	37200	35400
	10	-12.2	14000	13600	13100	12600	12100	11400	39800	38200	36600	34900	33200	31500
	5	-15.0	12600	12200	11800	11200	10700	10300	35500	34000	32400	31000	29500	28000
	0	-17.8	11200	10800	10400	10000	9570	9120	31400	30100	28700	27400	26100	24800
BEZA025H8  Compressor Model ZS19KAE / YS16KAE	40	4.4	30600	29500	28500	27500	26400	25300	86200	83000	79800	76600	73400	70200
	35	1.7	27800	26800	25900	25000	24000	23000	78000	75000	72000	69000	66000	63000
	30	-1.1	25300	24400	23500	22700	21700	20900	71000	68200	65500	62800	60100	57400
	25	-3.9	23000	22200	21400	20600	19800	18900	64000	61400	58900	56400	53900	51400
	20	-6.7	20800	20100	19400	18700	17900	17200	57000	54600	52300	50000	47700	45400
	15	-9.4	18800	18200	17600	17000	16200	15600	50000	47800	45700	43600	41500	39400
	10	-12.2	17100	16500	15900	15300	14700	14100	43000	41000	39100	37200	35300	33400
	5	-15.0	15400	14900	14400	13800	13300	12800	36000	34200	32500	30800	29100	27400
	0	-17.8	13800	13400	12900	12500	12000	11400	30000	28400	26900	25400	23900	22400
BEZA030H8  Compressor Model ZS21KAE / YS21KAE	40	4.4	39100	37800	36400	34900	33600	32100	109000	105500	102000	98500	95000	91500
	35	1.7	35700	34400	33200	31900	30600	29300	98000	94800	91600	88400	85200	82000
	30	-1.1	32400	31300	30200	29000	27900	26700	88000	85000	82000	79000	76000	73000
	25	-3.9	29500	28500	27500	26400	25400	24300	79000	76200	73400	70600	67800	65000
	20	-6.7	26800	25900	25000	24000	23100	22000	71000	68400	65800	63200	60600	58000
	15	-9.4	24300	23500	22700	21800	20900	20100	63000	60600	58200	55800	53400	51000
	10	-12.2	22000	21300	20600	19800	19000	18200	55000	52800	50600	48400	46200	44000
	5	-15.0	20000	19200	18600	17900	17200	16500	47000	45000	43000	41000	39000	37000
	0	-17.8	18000	17400	16700	16100	15500	14900	39000	37200	35500	33800	32100	30

# SELECTION CAPACITY DATA

# BEZ - SCROLL CONDENSING UNITS

## R407A High Temperature (cont'd)

Model BEZA	Saturated Suction Temp.		Selection Capacity BTU/h						Ambient Temperature	
	° F	° C	85°F	90°F	95°F	100°F	105°F	110°F		
			(29.4°C)	(32.2°C)	(35°C)	(37.8°C)	(40.6°C)	(43.3°C)		
BEZA061H8  Compressor Model ZB48KCE / YB44KAE	40	4.4	79900	76800	73600	70300	67000	-		
	35	1.7	73300	70500	67500	64500	61500	-		
	30	-1.1	67000	64400	61700	58900	56100	53100		
	25	-3.9	60900	58400	56000	53500	50900	48300		
	20	-6.7	55100	52800	50600	48300	46000	43600		
	15	-9.4	49500	47500	45400	43400	41300	39200		
	10	-12.2	44300	42500	40700	38800	36900	35000		
	5	-15.0	39500	37900	36200	34500	32900	31200		
	0	-17.8	35000	33500	32000	30600	29100	27700		
BEZA070H8  Compressor Model ZB57KCE / YB50KAE	40	4.4	95100	91900	88700	85500	82200	78800		
	35	1.7	86900	84100	81200	78300	75200	72200		
	30	-1.1	79400	76800	74200	71400	68700	65900		
	25	-3.9	72300	69900	67500	65100	62600	60000		
	20	-6.7	65500	63400	61300	59100	56800	54400		
	15	-9.4	59300	57400	55400	53500	51400	49200		
	10	-12.2	53500	51700	49900	48000	46200	44200		
	5	-15.0	47900	46400	44700	43100	41400	39500		
	0	-17.8	42700	41400	39800	38400	36700	35000		
BEZA076H8  Compressor Model ZB66K5E / YB56KAE	40	4.4	110000	106000	102000	97300	93000	88500		
	35	1.7	101000	96900	93100	89100	85100	80900		
	30	-1.1	91900	88400	84900	81100	77400	73600		
	25	-3.9	83400	80200	76900	73500	70100	66700		
	20	-6.7	75300	72300	69300	66200	63100	60100		
	15	-9.4	67500	64800	62100	59400	56600	53900		
	10	-12.2	60200	57700	55300	52900	50500	48300		
	5	-15.0	53400	51200	49100	47000	44900	43100		
	0	-17.8	47000	45100	43400	41600	40000	38600		
BEZA085H8  Compressor Model ZB76K5E / YB68KAE	40	4.4	125000	120000	115000	110000	105000	-		
	35	1.7	114000	110000	106000	101000	97000	-		
	30	-1.1	104000	101000	96900	93100	89300	85500		
	25	-3.9	95200	91900	88700	85400	82000	78500		
	20	-6.7	86600	83800	80900	78000	75000	71900		
	15	-9.4	78600	76100	73500	70800	68100	65300		
	10	-12.2	71000	68700	66400	63900	61400	58800		
	5	-15.0	63800	61600	59300	56900	54500	51900		
	0	-17.8	56700	54500	52200	49800	47300	44800		
BEZA110H8  Compressor Model ZB95K5E / YB83KAE	40	4.4	162000	156000	151000	145000	137000	131000		
	35	1.7	149000	144000	137000	131000	125000	119000		
	30	-1.1	135000	130000	125000	120000	113000	108000		
	25	-3.9	123000	118000	112000	107000	102000	96900		
	20	-6.7	110000	106000	101000	96400	91600	86700		
	15	-9.4	98400	94300	90100	85800	81500	77200		
	10	-12.2	87400	83600	79800	75900	72200	68300		
	5	-15.0	77000	73600	70200	66800	63400	60200		
	0	-17.8	67400	64400	61400	58400	55600	52900		
BEZA150H8  Compressor Model ZB114K5E / YB100KAE	40	4.4	189000	183000	176000	167000	160000	-		
	35	1.7	174000	166000	160000	153000	146000	-		
	30	-1.1	158000	152000	146000	139000	132000	126000		
	25	-3.9	142000	137000	131000	125000	119000	112000		
	20	-6.7	129000	124000	118000	112000	106000	101000		
	15	-9.4	114000	110000	105000	99900	94800	89800		
	10	-12.2	102000	97600	93000	88500	84000	79600		
	5	-15.0	90000	85900	82000	77900	74000	70300		
	0	-17.8	78800	75300	71800	68400	65200	62300		

Shaded Area Restriction: 20°F Max Superheat

SELECTION CAPACITY DATA

BEZ - SCROLL CONDENSING UNITS

**R448A R449A High Temperature**

Model BEZA	Saturated Suction Temp.		Selection Capacity BTU/h					
			Ambient Temperature					
	° F	° C	85°F (29.4°C)	90°F (32.2°C)	95°F (35°C)	100°F (37.8°C)	105°F (40.6°C)	110°F (43.3°C)
BEZA007H8  Compressor Model ZB114K5E / YB100KAE	40	4.4	10300	9910	9560	9200	8840	8490
	35	1.7	9390	9070	8750	8410	8080	7750
	30	-1.1	8570	8270	7970	7660	7350	7050
	25	-3.9	7780	7500	7230	6950	6670	6390
	20	-6.7	7030	6780	6530	6270	6010	5750
	15	-9.4	6330	6100	5880	5640	5410	5160
	10	-12.2	5680	5470	5260	5050	4840	4620
	5	-15.0	5060	4890	4700	4500	4310	4110
	0	-17.8	4510	4350	4180	4000	3830	3640
BEZA008H8  Compressor Model ZB07KAE / YB07KAE	40	4.4	12200	11800	11200	10800	10400	9960
	35	1.7	11100	10700	10300	9930	9530	9130
	30	-1.1	10100	9780	9410	9060	8690	8340
	25	-3.9	9190	8870	8550	8230	7900	7580
	20	-6.7	8310	8020	7730	7450	7160	6860
	15	-9.4	7480	7220	6960	6700	6440	6180
	10	-12.2	6700	6470	6240	6010	5780	5540
	5	-15.0	5980	5780	5570	5370	5160	4960
	0	-17.8	5320	5150	4960	4780	4600	4420
BEZA009H8  Compressor Model ZB08KAE / YB08KAE	40	4.4	13900	13300	12800	12300	11800	11100
	35	1.7	12800	12300	11800	11300	10800	10300
	30	-1.1	11600	11200	10800	10400	9910	9470
	25	-3.9	10600	10200	9840	9440	9060	8660
	20	-6.7	9610	9270	8920	8580	8240	7890
	15	-9.4	8660	8360	8060	7760	7460	7140
	10	-12.2	7780	7510	7250	6980	6720	6450
	5	-15.0	6960	6730	6490	6260	6020	5790
	0	-17.8	6220	6010	5800	5600	5390	5190
BEZA010H8  Compressor Model ZS09KAE / YS09KAE	40	4.4	16100	15600	15100	14600	13900	13300
	35	1.7	14500	14000	13600	13100	12600	12000
	30	-1.1	13100	12700	12300	11900	11300	10800
	25	-3.9	11800	11400	11100	10700	10300	9780
	20	-6.7	10600	10300	9990	9660	9280	8840
	15	-9.4	9530	9280	9020	8730	8390	8010
	10	-12.2	8570	8350	8130	7880	7600	7270
	5	-15.0	7700	7520	7330	7130	6880	6600
	0	-17.8	6900	6750	6600	6440	6240	6000
BEZA011H8  Compressor Model ZS11KAE / YS11KAE	40	4.4	18900	18300	17700	17000	16200	15400
	35	1.7	17100	16500	16000	15400	14700	13900
	30	-1.1	15400	15000	14500	13900	13300	12600
	25	-3.9	13900	13500	13100	12600	12100	11400
	20	-6.7	12500	12200	11800	11300	10900	10300
	15	-9.4	11300	11000	10700	10300	9880	9390
	10	-12.2	10200	9920	9640	9330	8980	8540
	5	-15.0	9150	8940	8720	8460	8150	7780
	0	-17.8	8220	8050	7860	7660	7400	7090
BEZA015H8  Compressor Model ZS13KAE / YS12KAE	40	4.4	21100	20400	19700	18800	17900	16800
	35	1.7	19100	18500	17800	17100	16200	15300
	30	-1.1	17300	16700	16100	15500	14700	13800
	25	-3.9	15600	15200	14600	14000	13300	12600
	20	-6.7	14100	13700	13200	12700	12200	11400
	15	-9.4	12700	12400	12000	11500	11000	10400
	10	-12.2	11400	11100	10800	10500	10000	9500
	5	-15.0	10300	10100	9830	9510	9130	8670
	0	-17.8	9300	9100	8880	8630	8320	7940
BEZA020H8  Compressor Model ZS15KAE / YS14KAE	40	4.4	24500	23700	22700	21600	20500	19100
	35	1.7	22400	21500	20700	19700	18600	17500
	30	-1.1	20300	19600	18800	17900	17000	15900
	25	-3.9	18400	17800	17100	16300	15400	14500
	20	-6.7	16600	16100	15500	14900	14000	13200
	15	-9.4	15100	14700	14100	13500	12800	12100
	10	-12.2	13600	13200	12800	12300	11800	11000
	5	-15.0	12300	12000	11600	11200	10700	10100
	0	-17.8	11100	10800	10600	10200	9800	9280

table continues in next column >>>

Model BEZA	Saturated Suction Temp.		Selection Capacity BTU/h					
			Ambient Temperature					
	° F	° C	85°F (29.4°C)	90°F (32.2°C)	95°F (35°C)	100°F (37.8°C)	105°F (40.6°C)	110°F (43.3°C)
BEZA025H8  Compressor Model ZS19KAE / YS16KAE	40	4.4	30000	29100	28200	27100	26000	24800
	35	1.7	26900	26200	25300	24300	23400	22300
	30	-1.1	24200	23500	22800	21900	21000	20100
	25	-3.9	21800	21200	20600	19900	19000	18100
	20	-6.7	19800	19100	18600	17900	17200	16300
	15	-9.4	17800	17300	16700	16200	15600	14900
	10	-12.2	16000	15600	15200	14700	14100	13500
	5	-15.0	14500	14100	13700	13300	12800	12300
	0	-17.8	13000	12700	12400	12000	11500	11000
BEZA030H8  Compressor Model ZS21KAE / YS21KAE	40	4.4	40700	39300	38000	36500	35200	33600
	35	1.7	37200	36100	34800	33500	32100	30800
	30	-1.1	34100	33000	31800	30600	29300	28100
	25	-3.9	31100	30100	28900	27900	26600	25500
	20	-6.7	28200	27200	26200	25200	24100	23000
	15	-9.4	25500	24600	23700	22800	21700	20600
	10	-12.2	23000	22200	21300	20400	19400	18400
	5	-15.0	20600	19900	19000	18200	17300	16300
	0	-17.8	18300	17700	16800	16000	15200	14200
BEZA035H8  Compressor Model ZS26KAE / YS24KAE	40	4.4	44200	42600	41000	39200	37200	35200
	35	1.7	40200	38900	37300	35600	33800	31700
	30	-1.1	36600	35300	33800	32200	30500	28600
	25	-3.9	33200	31900	30600	29100	27500	25600
	20	-6.7	30000	28800	27600	26200	24600	23000
	15	-9.4	27000	26000	24900	23500	22000	20500
	10	-12.2	24200	23300	22300	21100	19800	18200
	5	-15.0	21700	20900	20000	18800	17600	16200
	0	-17.8	19400	18700	17900	16800	15700	14500
BEZA040H8  Compressor Model ZS29KAE / YS26KAE	40	4.4	51600	49900	48200	46400	44600	42700
	35	1.7	47300	45800	44200	42500	40900	39100
	30	-1.1	43300	41800	40400	38900	37200	35700
	25	-3.9	39400	38100	36700	35400	33900	32300
	20	-6.7	35800	34500	33300	32000	30700	29200
	15	-9.4	32300	31200	30100	28800	27600	26200
	10	-12.2	29100	28100	27000	25900	24600	23400
	5	-15.0	26100	25200	24100	23100	21900	20700
	0	-17.8	23300	22400	21400	20400	19200	18100
BEZA045H8  Compressor Model ZS33KAE / YS30KAE	40	4.4	56200	54300	52300	50300	48400	46300
	35	1.7	51600	49800	48000	46200	44300	42300
	30	-1.1	47100	45600	43900	42200	40500	38600
	25	-3.9	43000	41500	40000	38500	36800	35000
	20	-6.7	39100	37800	36300	34800	33300	31700
	15	-9.4	35400	34100	32800	31400	30000	28500
	10	-12.2	31800	30700	29400	28200	26800	25400
	5	-15.0	28500	27500	26300	25200	23800	22500
	0	-17.8	25500	24400	23400	22300	21000	19700
BEZA050H8  Compressor Model ZB38KCE / YB34KAE	40	4.4	62600	60300	57900	55600	53400	51000
	35	1.7	57300	55200	53000	51000	48800	46600
	30	-1.1	52300	50400	48500	46500	44500	42500
	25	-3.9	47600	45900	44100	42200	40500	38700
	20	-6.7	43300	41600	39900	38300	36600	34900
	15	-9.4	39100	37500	36100	34500	33000	31500
	10	-12.2	35200	33800	32300	31000	29500	28200
	5	-15.0	31400	30200	28800	27600	26200	25000
	0	-17.8	27900	26700	25500	24200	23000	21800
BEZA060H8  Compressor Model ZB45KCE / YB40KAE	40	4.4	73700	71000	68200	65400	62700	59900
	35	1.7	67600	65100	62500	60000	57400	54900
	30	-1.1	61800	59500	57100	54800	52400	50100
	25	-3.9	56300	54200	52000	49900	47700	45600
	20	-6.7	51100	49200	47200	45200	43300	41300
	15	-9.4	46200	44400	42600	40800	39000	37100
	10	-12.2	41600	39900	38300	36600	34800	33200
	5	-15.0	37100	35700	34100	32600	31000	29400
	0	-17.8	33000	31500	30100	28600	27100	25700

table continues on next page >>>

Shaded Area Restriction: 20°F Max Superheat

# SELECTION CAPACITY DATA

# BEZ - SCROLL CONDENSING UNITS

## R448A R449A High Temperature (cont'd)

Model BEZA	Saturated Suction Temp.		Selection Capacity BTU/h					
			Ambient Temperature					
	° F	° C	85°F (29.4°C)	90°F (32.2°C)	95°F (35°C)	100°F (37.8°C)	105°F (40.6°C)	110°F (43.3°C)
BEZA061H8  Compressor Model ZB48KCE / YB44KAE	40	4.4	81400	78300	75200	72100	69000	65800
	35	1.7	74800	72000	69100	66100	63300	60400
	30	-1.1	68400	65800	63200	60500	57900	55200
	25	-3.9	62500	60100	57700	55200	52800	50300
	20	-6.7	56800	54600	52400	50100	47900	45700
	15	-9.4	51500	49400	47400	45300	43300	41200
	10	-12.2	46400	44500	42500	40700	38800	36900
	5	-15.0	41500	39700	38000	36200	34400	32800
	0	-17.8	36800	35300	33600	31900	30300	28700
BEZA070H8  Compressor Model ZB57KCE / YB50KAE	40	4.4	99400	96000	92500	88800	85100	81200
	35	1.7	90900	87800	84700	81400	78000	74600
	30	-1.1	83000	80200	77400	74500	71400	68300
	25	-3.9	75500	73000	70400	67800	65100	62400
	20	-6.7	68400	66200	64000	61700	59200	56800
	15	-9.4	61900	59900	57800	55700	53600	51400
	10	-12.2	55700	53900	52000	50100	48200	46200
	5	-15.0	49900	48300	46500	44700	43000	41200
	0	-17.8	44400	42800	41200	39600	38000	36200
BEZA076H8  Compressor Model ZB66K5E / YB56KAE	40	4.4	113000	109000	105000	101000	96800	91900
	35	1.7	103000	100000	97000	93400	89300	84900
	30	-1.1	94400	91800	88900	85700	82100	78100
	25	-3.9	85900	83500	81000	78100	74900	71300
	20	-6.7	77800	75700	73400	70800	67900	64700
	15	-9.4	70100	68200	66100	63800	61200	58100
	10	-12.2	62900	61200	59200	57000	54500	51700
	5	-15.0	56300	54500	52500	50400	48000	45200
	0	-17.8	50000	48200	46200	44100	41700	39000
BEZA085H8  Compressor Model ZB76K5E / YB68KAE	40	4.4	128000	124000	119000	114000	108000	103000
	35	1.7	118000	113000	109000	105000	101000	95300
	30	-1.1	107000	104000	101000	96800	92600	87900
	25	-3.9	97600	94800	91900	88500	84800	80500
	20	-6.7	88500	86100	83500	80500	77200	73300
	15	-9.4	79900	77700	75400	72700	69700	66100
	10	-12.2	71800	69800	67600	65100	62300	59100
	5	-15.0	64200	62200	60100	57700	55100	52100
	0	-17.8	57000	55000	52800	50500	48000	45100
BEZA110H8  Compressor Model ZB95K5E / YB83KAE	40	4.4	172000	165000	159000	152000	146000	138000
	35	1.7	154000	149000	144000	137000	131000	124000
	30	-1.1	139000	134000	129000	124000	118000	111000
	25	-3.9	125000	121000	115000	110000	105000	99500
	20	-6.7	112000	108000	104000	98900	93800	88400
	15	-9.4	101000	96600	92500	88000	83100	77900
	10	-12.2	89800	86000	82000	77500	72800	67700
	5	-15.0	79700	75900	71900	67400	62700	57500
	0	-17.8	69900	66100	62000	57400	52600	47300
BEZA150H8  Compressor Model ZB114K5E / YB100KAE	40	4.4	200000	192000	185000	177000	170000	160000
	35	1.7	181000	174000	167000	160000	153000	145000
	30	-1.1	163000	157000	151000	144000	137000	130000
	25	-3.9	147000	141000	135000	129000	123000	115000
	20	-6.7	131000	127000	121000	115000	109000	103000
	15	-9.4	118000	113000	108000	102000	96300	90100
	10	-12.2	105000	100000	95300	89900	84100	78000
	5	-15.0	92900	88300	83300	78000	72300	66100
	0	-17.8	81400	76800	71800	66400	60500	54300

Shaded Area Restriction: 20°F Max Superheat

**SELECTION CAPACITY DATA**

**BEZ - SCROLL CONDENSING UNITS**

**R407C High Temperature**

Model BEZA	Saturated Suction Temp.		Selection Capacity BTU/h						Ambient Temperature		
	°F	°C	85°F	90°F	95°F	100°F	105°F	110°F			
			(29.4°C)	(32.2°C)	(35°C)	(37.8°C)	(40.6°C)	(43.3°C)			
BEZA009H8  Compressor Model ZB06KAE / YB06KAE	40	4.4	13000	12500	12000	11500	11000	10500			
	35	1.7	11900	11400	10900	10500	10100	9700			
	30	-1.1	10700	10400	9990	9610	9250	8890			
	25	-3.9	9760	9410	9080	8760	8430	8130			
	20	-6.7	8820	8520	8230	7950	7680	7400			
	15	-9.4	7940	7680	7430	7180	6950	6720			
	10	-12.2	7110	6880	6670	6460	6260	6070			
	5	-15.0	6340	6150	5960	5770	5610	5450			
	0	-17.8	5630	5450	5280	5130	4980	4850			
	BEZA011H8  Compressor Model ZS11KAE / YS11KAE	40	4.4	17800	17300	16800	16200	15700	15200		
35		1.7	16300	15800	15400	14900	14400	14000			
30		-1.1	14900	14500	14000	13600	13200	12800			
25		-3.9	13500	13100	12800	12400	12000	11600			
20		-6.7	12200	11900	11500	11200	10900	10500			
15		-9.4	10900	10600	10400	10000	9720	9390			
10		-12.2	9730	9470	9200	8920	8620	8310			
5		-15.0	8580	8340	8090	7830	7550	7250			
0		-17.8	7470	7250	7020	6770	6500	6210			
BEZA015H8  Compressor Model ZS13KAE / YS12KAE		40	4.4	20700	20100	19600	18900	18300	17700		
	35	1.7	19000	18500	17900	17400	16800	16200			
	30	-1.1	17400	16800	16400	15900	15400	14900			
	25	-3.9	15800	15400	15000	14500	14000	13500			
	20	-6.7	14200	13900	13500	13100	12700	12300			
	15	-9.4	12800	12500	12200	11800	11300	10900			
	10	-12.2	11400	11100	10800	10400	10100	9700			
	5	-15.0	10100	9800	9500	9170	8830	8480			
	0	-17.8	8780	8520	8230	7920	7600	7250			
	BEZA020H8  Compressor Model ZS15KAE / YS14KAE	40	4.4	24200	23500	22800	22000	21300	20600		
35		1.7	22400	21600	21000	20400	19700	19000			
30		-1.1	20500	19900	19200	18600	18100	17500			
25		-3.9	18600	18100	17600	17100	16400	15900			
20		-6.7	16800	16400	15900	15400	14900	14400			
15		-9.4	15200	14800	14400	13800	13400	12900			
10		-12.2	13500	13200	12800	12400	11900	11400			
5		-15.0	12000	11600	11200	10800	10400	9970			
0		-17.8	10400	10100	9740	9370	8960	8530			
BEZA025H8  Compressor Model ZS19KAE / YS16KAE		40	4.4	29500	28600	27800	26900	26100	25300		
	35	1.7	26900	26200	25400	24600	23900	23200			
	30	-1.1	24400	23800	23200	22500	21800	21100			
	25	-3.9	22200	21600	21000	20400	19800	19100			
	20	-6.7	20000	19400	18900	18400	17800	17300			
	15	-9.4	17900	17400	17000	16400	15900	15400			
	10	-12.2	15800	15500	15000	14600	14000	13600			
	5	-15.0	13900	13600	13200	12800	12300	11900			
	0	-17.8	12200	11800	11400	11000	10600	10100			
	BEZA030H8  Compressor Model ZS21KAE / YS21KAE	40	4.4	38500	37400	36300	35200	34000	33000		
35		1.7	35300	34300	33300	32200	31300	30300			
30		-1.1	32100	31300	30400	29400	28600	27700			
25		-3.9	29200	28400	27600	26700	25900	25100			
20		-6.7	26300	25600	25000	24100	23400	22700			
15		-9.4	23600	23000	22400	21600	21000	20300			
10		-12.2	21000	20400	19900	19200	18500	17900			
5		-15.0	18500	18000	17400	16800	16200	15600			
0		-17.8	16000	15600	15100	14600	13900	13300			
BEZA035H8  Compressor Model ZS26KAE / YS24KAE		40	4.4	42200	41000	39700	38500	37300	36000		
	35	1.7	38700	37600	36500	35400	34200	33100			
	30	-1.1	35400	34300	33400	32300	31300	30300			
	25	-3.9	32000	31200	30400	29400	28500	27600			
	20	-6.7	29000	28200	27400	26600	25700	24900			
	15	-9.4	26000	25300	24500	23800	23100	22300			
	10	-12.2	23100	22500	21800	21100	20400	19700			
	5	-15.0	20400	19800	19100	18500	17900	17100			
	0	-17.8	17700	17200	16600	16000	15300	14600			

table continues in next column >>>

Model BEZA	Saturated Suction Temp.		Selection Capacity BTU/h						Ambient Temperature		
	°F	°C	85°F	90°F	95°F	100°F	105°F	110°F			
			(29.4°C)	(32.2°C)	(35°C)	(37.8°C)	(40.6°C)	(43.3°C)			
BEZA040H8  Compressor Model ZS29KAE / YS26KAE	40	4.4	47900	46600	45200	43800	42400	41100			
	35	1.7	43900	42600	41400	40200	38900	37600			
	30	-1.1	40000	38900	37900	36700	35600	34400			
	25	-3.9	36300	35400	34300	33400	32300	31200			
	20	-6.7	32800	31900	31000	30100	29100	28200			
	15	-9.4	29300	28600	27800	26900	26100	25200			
	10	-12.2	26100	25400	24600	23900	23100	22300			
	5	-15.0	23000	22400	21600	20900	20200	19300			
	0	-17.8	20000	19300	18700	18100	17400	16500			
	BEZA045H8  Compressor Model ZS33KAE / YS30KAE	40	4.4	52500	51000	49500	47900	46400	44800		
35		1.7	48200	46800	45300	44000	42600	41200			
30		-1.1	43900	42700	41500	40200	39000	37600			
25		-3.9	39800	38800	37600	36600	35400	34200			
20		-6.7	36000	35000	34000	33100	31900	30900			
15		-9.4	32200	31400	30500	29600	28600	27600			
10		-12.2	28700	28000	27100	26200	25400	24400			
5		-15.0	25300	24500	23800	23000	22200	21200			
0		-17.8	22000	21300	20600	19900	19000	18100			
BEZA050H8  Compressor Model ZB38KCE / YB34KAE		40	4.4	59600	57600	55600	53700	51700	49700		
	35	1.7	54500	52700	50900	49100	47200	45400			
	30	-1.1	49700	48000	46400	44700	43100	41400			
	25	-3.9	45100	43700	42200	40700	39100	37500			
	20	-6.7	41000	39600	38200	36800	35400	33900			
	15	-9.4	36900	35800	34400	33200	31800	30400			
	10	-12.2	33300	32100	31000	29700	28400	27100			
	5	-15.0	29800	28700	27700	26400	25300	24000			
	0	-17.8	26500	25600	24500	23400	22300	21000			
	BEZA060H8  Compressor Model ZB45KCE / YB40KAE	40	4.4	71700	69300	66700	64200	61500	58800		
35		1.7	65500	63200	60800	58400	56100	53600			
30		-1.1	59600	57500	55300	53100	50900	48600			
25		-3.9	54000	52000	50000	48000	46000	43900			
20		-6.7	48700	46900	45000	43300	41400	39500			
15		-9.4	43700	42000	40500	38800	37100	35600			
10		-12.2	39000	37500	36100	34600	33300	31800			
5		-15.0	34600	33400	32100	30900	29700	28600			
0		-17.8	30800	29600	28600	27600	26600	25700			
BEZA061H8  Compressor Model ZB48KCE / YB44KAE		40	4.4	75100	72400	69600	66700	63600	60500		
	35	1.7	68100	65600	63000	60400	57600	54800			
	30	-1.1	61400	59200	56800	54400	51900	49300			
	25	-3.9	55000	53000	50900	48700	46400	44000			
	20	-6.7	49100	47200	45200	43300	41200	38900			
	15	-9.4	43400	41700	39900	38100	36200	34100			
	10	-12.2	38100	36500	34900	33200	31400	29500			
	5	-15.0	33200	31700	30200	28600	26900	25200			
	0	-17.8	28500	27100	25800	24200	22700	21100			
	BEZA070H8  Compressor Model ZB57KCE / YB50KAE	40	4.4	93500	91000	88400	85700	83000	80100		
35		1.7	85200	82900	80500	78000	75400	72800			
30		-1.1	77500	75300	73100	70700	68400	65900			
25		-3.9	70100	68100	66000	64000	61800	59500			
20		-6.7	63200	61400	59500	57600	55600	53600			
15		-9.4	56800	55100	53400	51700	49800	48000			
10		-12.2	50800	49300	47700	46200	44600	43000			
5		-15.0	45200	43900	42500	41100	39700	38400			
0		-17.8	40100	38900	37800	36500	35400	34200			

# SELECTION CAPACITY DATA

# BEZ - SCROLL CONDENSING UNITS

## R407C High Temperature (cont'd)

Model BEZA	Saturated Suction Temp.		Selection Capacity BTU/h						Ambient Temperature	
	° F	° C	85°F	90°F	95°F	100°F	105°F	110°F		
			(29.4°C)	(32.2°C)	(35°C)	(37.8°C)	(40.6°C)	(43.3°C)		
BEZA076H8  Compressor Model ZB66K5E / YB56KAE	40	4.4	109000	106000	103000	99900	96600	93200		
	35	1.7	99600	96800	93900	90900	87800	84600		
	30	-1.1	90500	87800	85100	82300	79500	76500		
	25	-3.9	81800	79400	76900	74400	71700	69000		
	20	-6.7	73800	71600	69300	66900	64500	62000		
	15	-9.4	66400	64300	62200	60000	57700	55400		
	10	-12.2	59400	57500	55500	53600	51500	49400		
	5	-15.0	53000	51300	49500	47600	45700	43800		
	0	-17.8	47200	45600	43900	42100	40400	38600		
BEZA085H8  Compressor Model ZB76K5E / YB68KAE	40	4.4	125000	122000	118000	113000	110000	106000		
	35	1.7	114000	111000	107000	104000	100000	96700		
	30	-1.1	104000	101000	97900	94600	91400	88100		
	25	-3.9	94500	91700	88900	86000	83000	80000		
	20	-6.7	85600	83000	80500	77800	75100	72400		
	15	-9.4	77300	74900	72600	70200	67800	65300		
	10	-12.2	69500	67400	65300	63100	60900	58800		
	5	-15.0	62300	60400	58600	56600	54700	52700		
	0	-17.8	55600	54000	52300	50500	48900	47100		
BEZA110H8  Compressor Model ZB95K5E / YB83KAE	40	4.4	161000	156000	151000	146000	140000	134000		
	35	1.7	146000	140000	136000	131000	126000	121000		
	30	-1.1	131000	127000	123000	118000	113000	108000		
	25	-3.9	118000	114000	110000	106000	101000	96900		
	20	-6.7	106000	102000	98200	94200	90300	86200		
	15	-9.4	94200	90800	87300	83700	80000	76200		
	10	-12.2	83700	80500	77300	73900	70500	67100		
	5	-15.0	74000	71000	68000	65000	61800	58700		
	0	-17.8	65100	62400	59600	56700	53800	50800		
BEZA150H8  Compressor Model ZB114K5E / YB100KAE	40	4.4	184000	179000	173000	166000	160000	155000		
	35	1.7	167000	162000	157000	151000	146000	140000		
	30	-1.1	152000	147000	141000	137000	132000	127000		
	25	-3.9	136000	132000	128000	124000	119000	113000		
	20	-6.7	123000	119000	115000	110000	106000	102000		
	15	-9.4	110000	107000	103000	99000	95100	91000		
	10	-12.2	98600	95300	91700	88200	84600	80800		
	5	-15.0	87800	84700	81400	78200	74900	71400		
	0	-17.8	77800	74900	72000	69000	65800	62700		

Shaded Area Restriction: 20°F Max Superheat

**SELECTION CAPACITY DATA**

**BEZ - SCROLL CONDENSING UNITS**

**R404A R507 Low Temperature**

Model BEZA	Saturated Suction Temp.		Selection Capacity BTU/h						Ambient Temperature	
	° F	° C	85°F	90°F	95°F	100°F	105°F	110°F	105°F	110°F
			(29.4°C)	(32.2°C)	(35°C)	(37.8°C)	(40.6°C)	(43.3°C)		
BEZA008L8  Compressor Model ZF03KAE / YF03KAE	0	-17.8	5540	5310	5070	4840	4600	4360		
	-5	-20.6	4940	4740	4530	4330	4120	3910		
	-10	-23.3	4410	4230	4050	3870	3680	3500		
	-15	-26.1	3930	3770	3620	3460	3300	3140		
	-20	-28.9	3500	3370	3230	3100	2960	2820		
	-25	-31.7	3120	3010	2900	2780	2660	2540		
	-30	-34.4	2790	2690	2600	2500	2400	2290		
	-35	-37.2	2500	2420	2330	2250	2160	2070		
	-40	-40.0	2240	2170	2100	2030	1950	1880		
BEZA010L8  Compressor Model ZF04KAE / YF03KAE	0	-17.8	7320	7020	6710	6400	6080	5770		
	-5	-20.6	6560	6280	6000	5720	5440	5150		
	-10	-23.3	5850	5600	5350	5100	4850	4590		
	-15	-26.1	5200	4980	4750	4530	4300	4070		
	-20	-28.9	4600	4410	4210	4010	3810	3610		
	-25	-31.7	4070	3900	3730	3550	3380	3200		
	-30	-34.4	3600	3450	3310	3150	3000	2850		
	-35	-37.2	3200	3070	2940	2820	2680	2550		
	-40	-40.0	2860	2750	2650	2540	2430	2320		
BEZA015L8  Compressor Model ZF05KAE / YF05KAE	0	-17.8	8640	8280	7920	7550	7180	6800		
	-5	-20.6	7810	7480	7160	6820	6490	6150		
	-10	-23.3	7020	6730	6430	6140	5830	5520		
	-15	-26.1	6280	6020	5760	5490	5220	4940		
	-20	-28.9	5590	5360	5130	4890	4650	4400		
	-25	-31.7	4960	4750	4550	4340	4120	3900		
	-30	-34.4	4380	4200	4020	3840	3640	3450		
	-35	-37.2	3860	3710	3550	3390	3220	3050		
	-40	-40.0	3410	3280	3140	3000	2850	2700		
BEZA020L8  Compressor Model ZF07KAE / YF07KAE	0	-17.8	12200	11600	11000	10400	9790	9150		
	-5	-20.6	11100	10600	10100	9530	8960	8390		
	-10	-23.3	10100	9670	9190	8690	8190	7670		
	-15	-26.1	9190	8770	8340	7910	7460	7000		
	-20	-28.9	8290	7920	7550	7160	6770	6360		
	-25	-31.7	7440	7110	6780	6440	6100	5740		
	-30	-34.4	6610	6330	6040	5740	5440	5120		
	-35	-37.2	5810	5560	5300	5040	4770	4500		
	-40	-40.0	5010	4790	4560	4330	4100	3860		
BEZA025L8  Compressor Model ZF08K4E / YF06KSE	0	-17.8	15300	14600	14000	13300	12600	11900		
	-5	-20.6	13900	13300	12800	12200	11500	10900		
	-10	-23.3	12600	12100	11600	11100	10500	9930		
	-15	-26.1	11400	11000	10500	10000	9530	9010		
	-20	-28.9	10300	9880	9470	9040	8600	8140		
	-25	-31.7	9200	8860	8500	8120	7730	7320		
	-30	-34.4	8210	7900	7590	7250	6900	6540		
	-35	-37.2	7290	7020	6730	6440	6120	5800		
	-40	-40.0	6440	6200	5940	5670	5390	5100		
BEZA030L8  Compressor Model ZF09K4E / YF07KSE	0	-17.8	16900	16200	15500	14700	13900	13200		
	-5	-20.6	15400	14800	14100	13500	12800	12100		
	-10	-23.3	14000	13500	12900	12300	11700	11000		
	-15	-26.1	12700	12200	11700	11200	10600	10000		
	-20	-28.9	11500	11000	10600	10100	9620	9110		
	-25	-31.7	10300	9940	9540	9120	8680	8220		
	-30	-34.4	9240	8900	8540	8170	7780	7380		
	-35	-37.2	8210	7910	7590	7260	6920	6560		
	-40	-40.0	7230	6960	6680	6390	6090	5770		
BEZA035L8  Compressor Model ZF11K4E / YF09KSE	0	-17.8	20100	19100	18200	17200	16200	15200		
	-5	-20.6	18400	17600	16700	15900	14900	14000		
	-10	-23.3	16800	16100	15300	14500	13700	12900		
	-15	-26.1	15300	14600	14000	13300	12500	11800		
	-20	-28.9	13800	13300	12700	12100	11400	10700		
	-25	-31.7	12500	12000	11400	10900	10300	9720		
	-30	-34.4	11200	10700	10300	9800	9300	8760		
	-35	-37.2	9940	9560	9170	8750	8310	7850		
	-40	-40.0	8780	8460	8110	7750	7370	6960		

table continues in next column >>>

Model BEZA	Saturated Suction Temp.		Selection Capacity BTU/h						Ambient Temperature	
	° F	° C	85°F	90°F	95°F	100°F	105°F	110°F	105°F	110°F
			(29.4°C)	(32.2°C)	(35°C)	(37.8°C)	(40.6°C)	(43.3°C)		
BEZA045L8  Compressor Model ZF13K4E / YF10KAE	0	-17.8	25100	24100	23000	21900	20800	19600		
	-5	-20.6	22800	21900	20900	19900	18900	17800		
	-10	-23.3	20600	19700	18900	18000	17000	16100		
	-15	-26.1	18500	17700	17000	16200	15300	14500		
	-20	-28.9	16600	15900	15200	14500	13800	13000		
	-25	-31.7	14700	14100	13500	12900	12300	11700		
	-30	-34.4	13000	12500	12000	11500	11000	10400		
	-35	-37.2	11400	11000	10600	10200	9740	9320		
	-40	-40.0	9990	9630	9290	8950	8620	8300		
BEZA055L8  Compressor Model ZF15K4E / YF13KAE	0	-17.8	30900	29600	28300	27000	25600	24200		
	-5	-20.6	28000	26900	25700	24500	23300	22000		
	-10	-23.3	25300	24300	23300	22200	21100	20000		
	-15	-26.1	22800	21900	21000	20100	19100	18100		
	-20	-28.9	20500	19700	18900	18100	17200	16300		
	-25	-31.7	18300	17600	16900	16200	15400	14700		
	-30	-34.4	16300	15700	15100	14500	13800	13100		
	-35	-37.2	14500	13900	13400	12800	12300	11700		
	-40	-40.0	12700	12300	11800	11300	10800	10300		
BEZA060L8  Compressor Model ZF18K4E / YF15KAE	0	-17.8	36100	34600	33100	31600	30000	28400		
	-5	-20.6	32900	31600	30200	28900	27500	26000		
	-10	-23.3	29800	28700	27500	26300	25100	23800		
	-15	-26.1	27000	26000	24900	23900	22800	21700		
	-20	-28.9	24300	23400	22500	21600	20600	19600		
	-25	-31.7	21800	21000	20200	19400	18600	17700		
	-30	-34.4	19400	18800	18100	17400	16700	15900		
	-35	-37.2	17200	16600	16100	15400	14800	14200		
	-40	-40.0	15100	14600	14100	13600	13000	12500		
BEZA075L8  Compressor Model ZF25K4E / YF19KAE	0	-17.8	45300	43600	41800	40000	38100	36300		
	-5	-20.6	41100	39500	37900	36300	34600	33000		
	-10	-23.3	37200	35800	34300	32900	31400	29900		
	-15	-26.1	33500	32200	31000	29700	28400	27100		
	-20	-28.9	30100	29000	27800	26700	25600	24500		
	-25	-31.7	26900	25900	25000	24000	23000	22100		
	-30	-34.4	24000	23100	22300	21500	20700	19900		
	-35	-37.2	21200	20500	19800	19200	18500	17900		
	-40	-40.0	18700	18200	17600	17100	16600	16100		
BEZA085L8  Compressor Model ZF28K4E / YF22KAE	0	-17.8	50400	48400	46400	44300	42200	40000		
	-5	-20.6	45900	44000	42200	40300	38400	36500		
	-10	-23.3	41600	39900	38300	36600	34900	33200		
	-15	-26.1	37500	36100	34600	33100	31700	30200		
	-20	-28.9	33800	32500	31200	29900	28600	27400		
	-25	-31.7	30200	29100	28000	26900	25800	24700		
	-30	-34.4	27000	26000	25100	24100	23200	22400		
	-35	-37.2	23900	23100	22400	21600	20900	20200		
	-40	-40.0	21200	20500	19900	19300	18700	18200		
BEZA100L8  Compressor Model ZF34K5E / YF26KAE	0	-17.8	56500	54000	51500	48900	46200	43400		
	-5	-20.6	51600	49400	47200	44800	42400	39900		
	-10	-23.3	47000	45100	43000	41000	38800	36500		
	-15	-26.1	42700	40900	39100	37300	35300	33300		
	-20	-28.9	38500	37000	35400	33700	32000	30200		
	-25	-31.7	34500	33200	31800	30300	28800	27200		
	-30	-34.4	30800	29600	28300	27100	25700	24400		
	-35	-37.2	27200	26100	25000	23900	22700	21500		
	-40	-40.0	23700	22800	21800	20900	19800	18700		
BEZA130L8  Compressor Model ZF41K5E / YF32KAE	0	-17.8	72400	69500	66400	63300	60100	56700		
	-5	-20.6	66100	63500	60700	57900	55000	52000		
	-10	-23.3	60100	57800	55400	52900	50300	47600		
	-15	-26.1	54500	52400	50300	48100	45700	43300		
	-20	-28.9	49200	47400	45500	43500	41400	39300		
	-25	-31.7	44200	42600	40900	39200	37300	35400		

**SELECTION CAPACITY DATA**

**BEZ - SCROLL CONDENSING UNITS**

**R404A R507 Low Temperature (cont'd)**

Model BEZA	Saturated Suction Temp.		Selection Capacity BTU/h						Ambient Temperature	
	° F	° C	85°F	90°F	95°F	100°F	105°F	110°F	° F	° C
			(29.4°C)	(32.2°C)	(35°C)	(37.8°C)	(40.6°C)	(43.3°C)		
BEZA150L8  Compressor Model ZF49K5E / YF38KAE	0	-17.8	85100	81500	77800	74000	70000	66000		
	-5	-20.6	77700	74500	71100	67700	64100	60400		
	-10	-23.3	70700	67800	64800	61700	58500	55100		
	-15	-26.1	64000	61400	58800	56000	53100	50100		
	-20	-28.9	57700	55400	53100	50600	48000	45300		
	-25	-31.7	51800	49800	47700	45500	43200	40800		
	-30	-34.4	46300	44500	42600	40700	38600	36500		
	-35	-37.2	41100	39500	37900	36100	34300	32400		
	-40	-40.0	36300	34900	33400	31900	30200	28500		
BEZA170L8  Compressor Model ZF54K5E / YF44KAE	0	-17.8	103000	99000	95100	91100	87000	82700		
	-5	-20.6	93200	89800	86300	82700	79100	75200		
	-10	-23.3	84100	81100	78000	74900	71600	68200		
	-15	-26.1	75700	73100	70400	67600	64700	61700		
	-20	-28.9	67900	65600	63200	60800	58200	55600		
	-25	-31.7	60700	58700	56600	54500	52200	49800		
	-30	-34.4	54000	52300	50500	48600	46600	44500		
	-35	-37.2	47900	46400	44800	43100	41300	39400		
	-40	-40.0	42300	40900	39500	38000	36400	34700		

**R407A Low Temperature**

Model BEZA	Saturated Suction Temp.		Selection Capacity BTU/h						Ambient Temperature	
	° F	° C	85°F	90°F	95°F	100°F	105°F	110°F	° F	° C
			(29.4°C)	(32.2°C)	(35°C)	(37.8°C)	(40.6°C)	(43.3°C)		
BEZA008L8  Compressor Model ZF54K5E / YF44KAE	0	-17.8	4830	4650	4470	4310	4150	4000		
	-5	-20.6	4310	4150	4000	3850	3720	3590		
	-10	-23.3	3830	3700	3570	3450	3340	3230		
	-15	-26.1	3410	3300	3190	3090	2990	2900		
	-20	-28.9	3030	2940	2850	2760	2680	2600		
	-25	-31.7	2710	2630	2540	2470	2390	2330		
	-30	-34.4	2420	2340	2270	2210	2140	2080		
	-35	-37.2	2160	2090	2030	1960	1900	1850		
	-40	-40.0	1920	1860	1800	1730	1680	1630		
BEZA010L8  Compressor Model ZF04KAE / YF03KAE	0	-17.8	6590	6350	6100	5850	5590	5320		
	-5	-20.6	5840	5630	5410	5180	4950	4710		
	-10	-23.3	5160	4960	4770	4570	4370	4170		
	-15	-26.1	4530	4360	4190	4020	3840	3660		
	-20	-28.9	3960	3810	3680	3530	3370	3210		
	-25	-31.7	3470	3340	3210	3090	2960	2840		
	-30	-34.4	3030	2930	2820	2720	2610	2500		
	-35	-37.2	2680	2590	2510	2420	2330	2240		
	-40	-40.0	2390	2330	2260	2180	2110	2030		
BEZA015L8  Compressor Model ZF05KAE / YF05KAE	0	-17.8	7720	7430	7140	6850	6540	6240		
	-5	-20.6	6860	6600	6340	6070	5810	5530		
	-10	-23.3	6060	5830	5600	5370	5120	4880		
	-15	-26.1	5320	5120	4910	4710	4500	4290		
	-20	-28.9	4650	4480	4310	4130	3950	3760		
	-25	-31.7	4060	3920	3760	3610	3450	3300		
	-30	-34.4	3540	3410	3290	3160	3030	2900		
	-35	-37.2	3090	2990	2890	2780	2680	2570		
	-40	-40.0	2720	2640	2550	2480	2390	2310		
BEZA020L8  Compressor Model ZF07KAE / YF07KAE	0	-17.8	11200	10700	10200	9740	9220	8660		
	-5	-20.6	10100	9680	9250	8800	8330	7830		
	-10	-23.3	9080	8730	8340	7940	7520	7080		
	-15	-26.1	8150	7830	7500	7140	6760	6360		
	-20	-28.9	7280	7000	6710	6390	6060	5700		
	-25	-31.7	6470	6230	5960	5690	5390	5070		
	-30	-34.4	5700	5490	5260	5010	4750	4450		
	-35	-37.2	4970	4780	4580	4360	4120	3850		
	-40	-40.0	4250	4080	3910	3710	3490	3240		

Model BEZA	Saturated Suction Temp.		Selection Capacity BTU/h						Ambient Temperature	
	° F	° C	85°F	90°F	95°F	100°F	105°F	110°F	° F	° C
			(29.4°C)	(32.2°C)	(35°C)	(37.8°C)	(40.6°C)	(43.3°C)		
BEZA025L8  Compressor Model ZF08K4E / YF06KSE	0	-17.8	14100	13500	13100	12600	12100	11400		
	-5	-20.6	12600	12200	11800	11300	10800	10300		
	-10	-23.3	11300	10900	10500	10100	9710	9270		
	-15	-26.1	10100	9730	9390	9030	8650	8260		
	-20	-28.9	8900	8620	8320	8000	7670	7320		
	-25	-31.7	7830	7580	7320	7050	6750	6450		
	-30	-34.4	6860	6640	6410	6160	5900	5640		
	-35	-37.2	5960	5780	5570	5360	5130	4900		
	-40	-40.0	5170	4990	4810	4620	4420	4220		
BEZA030L8  Compressor Model ZF09K4E / YF07KSE	0	-17.8	15500	15000	14600	14100	13400	12800		
	-5	-20.6	13700	13200	12800	12300	11800	11200		
	-10	-23.3	12000	11700	11200	10800	10300	9820		
	-15	-26.1	10500	10200	9850	9460	9040	8580		
	-20	-28.9	9230	8940	8620	8280	7920	7500		
	-25	-31.7	8060	7810	7540	7250	6930	6560		
	-30	-34.4	7010	6790	6570	6330	6060	5750		
	-35	-37.2	6050	5880	5700	5510	5300	5050		
	-40	-40.0	5160	5030	4910	4780	4620	4430		
BEZA035L8  Compressor Model ZF11K4E / YF09KSE	0	-17.8	18900	18300	17600	16900	16100	15100		
	-5	-20.6	16600	16100	15500	14800	14100	13200		
	-10	-23.3	14700	14200	13700	13000	12400	11700		
	-15	-26.1	12900	12400	12000	11400	10800	10200		
	-20	-28.9	11200	10900	10500	10000	9480	8890		
	-25	-31.7	9850	9520	9170	8780	8330	7800		
	-30	-34.4	8580	8310	8020	7700	7320	6880		
	-35	-37.2	7420	7210	6990	6740	6440	6080		
	-40	-40.0	6360	6220	6060	5880	5670	5400		
BEZA045L8  Compressor Model ZF13K4E / YF10KAE	0	-17.8	23000	22300	21500	20700	20000	19100		
	-5	-20.6	20600	19800	19200	18500	17700	16900		
	-10	-23.3	18300	17600	17000	16300	15600	14900		
	-15	-26.1	16100	15500	14900	14300	13700	13000		
	-20	-28.9	14200	13700	13000	12500	12000	11300		
	-25	-31.7	12400	11900	11400	10900	10400	9860		
	-30	-34.4	10800	10400	10000	9580	9140	8670		
	-35	-37.2	9500	9190	8860	8530	8160	7780		
	-40	-40.0	8520	8270	8040	7790	7520	7210		

table continues in next column >>>

table continues on next page >>>

**SELECTION CAPACITY DATA**

**BEZ - SCROLL CONDENSING UNITS**

**R407A Low Temperature (cont'd)**

Model BEZA	Saturated Suction Temp.		Selection Capacity BTU/h					
			Ambient Temperature					
	° F	° C	85°F (29.4°C)	90°F (32.2°C)	95°F (35°C)	100°F (37.8°C)	105°F (40.6°C)	110°F (43.3°C)
BEZA055L8  Compressor Model ZF15K4E / YF13KAE	0	-17.8	28100	27200	26300	25400	24400	23400
	-5	-20.6	25100	24400	23500	22600	21700	20800
	-10	-23.3	22400	21600	20800	20100	19200	18400
	-15	-26.1	19700	19100	18400	17600	16900	16100
	-20	-28.9	17400	16800	16200	15500	14800	14100
	-25	-31.7	15300	14800	14300	13700	13000	12300
	-30	-34.4	13500	13000	12600	12100	11400	10800
	-35	-37.2	12100	11700	11200	10700	10200	9650
	-40	-40.0	10900	10500	10200	9740	9290	8790
BEZA060L8  Compressor Model ZF18K4E / YF15KAE	0	-17.8	33200	32100	31100	30000	29000	27800
	-5	-20.6	29800	28900	27900	26900	25900	24900
	-10	-23.3	26600	25700	24900	23900	23000	22100
	-15	-26.1	23500	22800	22100	21200	20400	19400
	-20	-28.9	20800	20200	19400	18700	18000	17100
	-25	-31.7	18400	17700	17100	16500	15800	15000
	-30	-34.4	16200	15600	15100	14500	13900	13200
	-35	-37.2	14400	13900	13400	12900	12400	11800
	-40	-40.0	12900	12500	12200	11700	11200	10700
BEZA075L8  Compressor Model ZF25K4E / YF19KAE	0	-17.8	41400	40100	38700	37500	36100	34700
	-5	-20.6	37200	36000	34800	33500	32200	31000
	-10	-23.3	33100	32000	31000	29800	28700	27500
	-15	-26.1	29400	28500	27400	26500	25400	24300
	-20	-28.9	25900	25100	24300	23300	22400	21300
	-25	-31.7	22900	22100	21300	20500	19600	18700
	-30	-34.4	20200	19500	18800	18100	17300	16500
	-35	-37.2	17900	17300	16700	16100	15400	14700
	-40	-40.0	16100	15600	15100	14600	14000	13300
BEZA085L8  Compressor Model ZF28K4E / YF22KAE	0	-17.8	47700	46100	44500	42900	41300	39600
	-5	-20.6	42800	41400	40000	38500	37000	35400
	-10	-23.3	38200	37000	35600	34300	32900	31400
	-15	-26.1	33900	32800	31600	30300	29100	27700
	-20	-28.9	30000	29000	27900	26800	25600	24400
	-25	-31.7	26500	25500	24600	23600	22600	21400
	-30	-34.4	23400	22600	21700	20900	20000	18900
	-35	-37.2	20800	20100	19300	18600	17700	16800
	-40	-40.0	18700	18200	17500	16900	16200	15300
BEZA100L8  Compressor Model ZF34K5E / YF26KAE	0	-17.8	55800	53800	51800	49700	47500	45200
	-5	-20.6	50100	48300	46400	44500	42500	40300
	-10	-23.3	44700	43100	41400	39600	37700	35700
	-15	-26.1	39700	38200	36600	35100	33300	31400
	-20	-28.9	35000	33700	32300	30800	29200	27500
	-25	-31.7	30800	29600	28400	27000	25500	23900
	-30	-34.4	27100	26000	24900	23700	22400	20900
	-35	-37.2	23900	23000	22100	20900	19700	18400
	-40	-40.0	21400	20700	19700	18800	17600	16500
BEZA130L8  Compressor Model ZF41K5E / YF32KAE	0	-17.8	70100	67900	65800	63500	61100	58700
	-5	-20.6	63000	61100	59100	57000	54800	52500
	-10	-23.3	56300	54500	52700	50800	48700	46600
	-15	-26.1	50100	48400	46700	44900	43200	41100
	-20	-28.9	44200	42800	41300	39700	37900	36100
	-25	-31.7	39100	37700	36300	34900	33300	31500
	-30	-34.4	34400	33300	32000	30700	29200	27600
	-35	-37.2	30600	29500	28400	27200	25800	24400
	-40	-40.0	27400	26500	25500	24400	23100	21700
BEZA150L8  Compressor Model ZF49K5E / YF38KAE	0	-17.8	83400	80600	77900	75100	72000	68900
	-5	-20.6	74900	72300	69800	67200	64400	61400
	-10	-23.3	66800	64500	62200	59700	57100	54300
	-15	-26.1	59100	57100	55000	52700	50300	47700
	-20	-28.9	52200	50400	48400	46300	44100	41700
	-25	-31.7	46000	44300	42500	40600	38500	36300
	-30	-34.4	40500	39100	37500	35700	33800	31700
	-35	-37.2	36000	34700	33300	31700	29900	28000
	-40	-40.0	32600	31400	30100	28700	27100	25300

Model BEZA	Saturated Suction Temp.		Selection Capacity BTU/h					
			Ambient Temperature					
	° F	° C	85°F (29.4°C)	90°F (32.2°C)	95°F (35°C)	100°F (37.8°C)	105°F (40.6°C)	110°F (43.3°C)
BEZA170L8  Compressor Model ZF54K5E / YF44KAE	0	-17.8	93300	90300	87300	84200	81100	77800
	-5	-20.6	83400	80700	78100	75400	72600	69800
	-10	-23.3	74200	71900	69600	67200	64800	62400
	-15	-26.1	65800	63800	61700	59700	57600	55400
	-20	-28.9	58100	56400	54600	52800	50900	49000
	-25	-31.7	51100	49600	48000	46400	44800	43200
	-30	-34.4	44800	43500	42100	40600	39300	37800
	-35	-37.2	39200	37900	36600	35400	34100	32800
	-40	-40.0	34000	32900	31700	30600	29400	28100

table continues in next column >>>

**SELECTION CAPACITY DATA**

**BEZ - SCROLL CONDENSING UNITS**

**R448A R449A Low Temperature**

Model BEZA	Saturated Suction Temp.		Selection Capacity BTU/h					
			Ambient Temperature					
	° F	° C	85°F (29.4°C)	90°F (32.2°C)	95°F (35°C)	100°F (37.8°C)	105°F (40.6°C)	110°F (43.3°C)
BEZA008L8  Compressor Model ZF03KAE / YF03KAE	0	-17.8	5090	4910	4740	4570	4400	4230
	-5	-20.6	4540	4390	4230	4080	3940	3800
	-10	-23.3	4050	3920	3790	3650	3530	3410
	-15	-26.1	3610	3500	3390	3280	3170	3070
	-20	-28.9	3220	3130	3030	2930	2850	2750
	-25	-31.7	2880	2790	2710	2630	2540	2460
	-30	-34.4	2560	2490	2420	2340	2270	2190
	-35	-37.2	2280	2220	2140	2070	2000	1930
-40	-40.0	2020	1950	1880	1820	1740	1680	
BEZA010L8  Compressor Model ZF04KAE / YF03KAE	0	-17.8	6900	6660	6420	6160	5910	5660
	-5	-20.6	6140	5920	5710	5490	5270	5040
	-10	-23.3	5440	5250	5060	4870	4670	4470
	-15	-26.1	4800	4630	4460	4290	4130	3960
	-20	-28.9	4210	4070	3930	3780	3630	3490
	-25	-31.7	3690	3570	3440	3320	3200	3080
	-30	-34.4	3220	3130	3020	2920	2810	2710
	-35	-37.2	2840	2750	2670	2580	2490	2400
-40	-40.0	2510	2440	2360	2300	2230	2150	
BEZA015L8  Compressor Model ZF05KAE / YF05KAE	0	-17.8	8070	7790	7510	7210	6920	6620
	-5	-20.6	7220	6970	6710	6450	6180	5910
	-10	-23.3	6420	6200	5960	5730	5500	5260
	-15	-26.1	5670	5480	5280	5070	4860	4650
	-20	-28.9	4990	4820	4640	4460	4280	4100
	-25	-31.7	4370	4220	4070	3920	3760	3600
	-30	-34.4	3810	3690	3560	3420	3290	3150
	-35	-37.2	3330	3210	3110	2990	2880	2760
-40	-40.0	2910	2810	2720	2630	2530	2440	
BEZA020L8  Compressor Model ZF07KAE / YF07KAE	0	-17.8	11600	11100	10600	10200	9720	9260
	-5	-20.6	10400	9990	9600	9190	8780	8370
	-10	-23.3	9330	8990	8640	8280	7930	7570
	-15	-26.1	8380	8090	7780	7480	7160	6840
	-20	-28.9	7510	7250	6980	6720	6450	6170
	-25	-31.7	6700	6480	6250	6020	5790	5550
	-30	-34.4	5940	5740	5550	5360	5160	4960
	-35	-37.2	5210	5040	4880	4700	4540	4360
-40	-40.0	4490	4350	4200	4050	3910	3750	
BEZA025L8  Compressor Model ZF08K4E / YF06KSE	0	-17.8	14800	14400	14000	13400	12900	12400
	-5	-20.6	13300	12900	12500	12100	11700	11200
	-10	-23.3	12000	11600	11200	10800	10500	10100
	-15	-26.1	10600	10300	10000	9690	9360	9000
	-20	-28.9	9460	9190	8900	8620	8320	8010
	-25	-31.7	8360	8130	7880	7620	7360	7100
	-30	-34.4	7360	7150	6930	6710	6480	6250
	-35	-37.2	6460	6270	6070	5870	5670	5460
-40	-40.0	5640	5460	5280	5100	4920	4740	
BEZA030L8  Compressor Model ZF09K4E / YF07KSE	0	-17.8	15800	15200	14800	14400	13900	13300
	-5	-20.6	14200	13900	13400	13000	12600	12200
	-10	-23.3	12800	12500	12200	11900	11400	11000
	-15	-26.1	11600	11200	11000	10700	10300	9950
	-20	-28.9	10300	10100	9860	9590	9280	8940
	-25	-31.7	9200	9010	8790	8550	8260	7950
	-30	-34.4	8140	7960	7770	7550	7290	6990
	-35	-37.2	7120	6960	6780	6570	6330	6040
-40	-40.0	6140	6000	5820	5620	5380	5090	
BEZA035L8  Compressor Model ZF11K4E / YF09KSE	0	-17.8	19300	18600	18000	17200	16500	15800
	-5	-20.6	17400	16800	16300	15600	14900	14300
	-10	-23.3	15600	15100	14600	14100	13400	12900
	-15	-26.1	14100	13500	13100	12600	12200	11700
	-20	-28.9	12500	12200	11800	11300	10900	10400
	-25	-31.7	11100	10800	10500	10100	9710	9310
	-30	-34.4	9900	9610	9300	8980	8650	8300
	-35	-37.2	8770	8510	8240	7960	7680	7370
-40	-40.0	7740	7520	7280	7040	6780	6520	

table continues in next column >>>

Model BEZA	Saturated Suction Temp.		Selection Capacity BTU/h					
			Ambient Temperature					
	° F	° C	85°F (29.4°C)	90°F (32.2°C)	95°F (35°C)	100°F (37.8°C)	105°F (40.6°C)	110°F (43.3°C)
BEZA045L8  Compressor Model ZF13K4E / YF10KAE	0	-17.8	24600	23700	22700	21700	20700	19600
	-5	-20.6	22100	21200	20400	19400	18500	17500
	-10	-23.3	19600	18900	18200	17300	16500	15600
	-15	-26.1	17400	16800	16100	15400	14700	14000
	-20	-28.9	15300	14800	14200	13700	13000	12500
	-25	-31.7	13400	12900	12500	12000	11600	11100
	-30	-34.4	11800	11300	10900	10600	10300	9940
	-35	-37.2	10200	9900	9630	9390	9180	8990
-40	-40.0	8850	8650	8490	8370	8280	8240	
BEZA055L8  Compressor Model ZF15K4E / YF13KAE	0	-17.8	30000	28900	27700	26500	25200	23900
	-5	-20.6	27000	25900	24900	23800	22800	21600
	-10	-23.3	24000	23200	22300	21400	20400	19400
	-15	-26.1	21400	20700	19800	19100	18300	17400
	-20	-28.9	19000	18400	17600	17000	16300	15500
	-25	-31.7	16800	16200	15600	15100	14500	14000
	-30	-34.4	14700	14300	13900	13300	12900	12500
	-35	-37.2	12900	12600	12200	11900	11600	11200
-40	-40.0	11300	11000	10800	10500	10300	10100	
BEZA060L8  Compressor Model ZF18K4E / YF15KAE	0	-17.8	35200	33800	32400	3100	29700	28200
	-5	-20.6	31700	30600	29400	28100	26900	25600
	-10	-23.3	28500	27400	26500	25400	24300	23200
	-15	-26.1	25400	24600	23700	22800	21800	21000
	-20	-28.9	22600	21800	21100	20400	19600	18900
	-25	-31.7	20000	19400	18800	18200	17600	17000
	-30	-34.4	17600	17100	16700	16200	15800	15300
	-35	-37.2	15400	15100	14700	14400	14100	13900
-40	-40.0	13400	13200	13000	12800	12600	12500	
BEZA075L8  Compressor Model ZF25K4E / YF19KAE	0	-17.8	44100	42600	41100	39400	37800	36100
	-5	-20.6	39600	38200	36800	35400	33900	32600
	-10	-23.3	35300	34000	32900	31600	30300	29200
	-15	-26.1	31400	30200	29200	28200	27200	26100
	-20	-28.9	27700	26900	25900	25100	24300	23500
	-25	-31.7	24500	23700	23000	22400	21700	21200
	-30	-34.4	21500	20900	20400	20000	19500	19200
	-35	-37.2	18900	18500	18100	17900	17600	17500
-40	-40.0	16600	16400	16200	16100	16100	16200	
BEZA085L8  Compressor Model ZF28K4E / YF22KAE	0	-17.8	50600	48700	46800	44900	43100	41200
	-5	-20.6	45500	43800	42100	40500	38900	37200
	-10	-23.3	40600	39200	37700	36300	34900	33500
	-15	-26.1	36100	35000	33700	32400	31300	30100
	-20	-28.9	32000	31000	29900	29000	28000	27100
	-25	-31.7	28200	27400	26600	25800	25200	24600
	-30	-34.4	24900	24300	23600	23100	22700	22400
	-35	-37.2	21900	21400	21100	20800	20600	20500
-40	-40.0	19300	19100	18900	18900	18900	19100	
BEZA100L8  Compressor Model ZF34K5E / YF26KAE	0	-17.8	55200	53300	51300	49400	47100	44900
	-5	-20.6	49900	48200	46400	44500	42600	40600
	-10	-23.3	44800	43400	41800	40100	38400	36600
	-15	-26.1	40100	38700	37400	35900	34400	32900
	-20	-28.9	35600	34400	33300	32000	30800	29400
	-25	-31.7	31500	30500	29400	28400	27300	26100
	-30	-34.4	27600	26700	25800	25000	24000	23200
	-35	-37.2	23900	23200	22500	21700	21000	20400
-40	-40.0	20500	19800	19300	18800	18300	17700	
BEZA130L8  Compressor Model ZF41K5E / YF32KAE	0	-17.8	71300	69100	66900	64500	62100	59500
	-5	-20.6	64400	62400	60400	58300	56100	53900
	-10	-23.3	57900	56200	54300	52500	50500	48500
	-15	-26.1	51800	50200	48600	47000	45300	43600
	-20	-28.9	46100	44700	43400	41900	40400	38900
	-25	-31.7	40700	39600	38300	37100	35800	34500
	-30	-34.4	35700	34800	33700	32700	31600	30500
	-35	-37.2	31100	30200	29300	28500	27600	26700
-40	-40.0	26800	26000	25300	24600	23800	23100	

table continues on next page >>>

# SELECTION CAPACITY DATA

# BEZ - SCROLL CONDENSING UNITS

## R448A R449A Low Temperature (cont'd)

Model BEZA	Saturated Suction Temp.		Selection Capacity BTU/h					
			Ambient Temperature					
	° F	° C	85°F (29.4°C)	90°F (32.2°C)	95°F (35°C)	100°F (37.8°C)	105°F (40.6°C)	110°F (43.3°C)
BEZA150L8  Compressor Model ZF49K5E / YF38KAE	0	-17.8	84700	82000	79200	76200	73200	70000
	-5	-20.6	76400	73900	71400	68800	66000	63200
	-10	-23.3	68600	66400	64200	61700	59300	56800
	-15	-26.1	61200	59300	57300	55200	53100	50800
	-20	-28.9	54400	52700	50900	49100	47300	45400
	-25	-31.7	48100	46600	45000	43500	41900	40200
	-30	-34.4	42200	41000	39600	38300	37000	35600
	-35	-37.2	36800	35700	34700	33500	32400	31400
	-40	-40.0	31900	31000	30100	29300	28400	27600
BEZA170L8  Compressor Model ZF54K5E / YF44KAE	0	-17.8	96100	93000	89900	86800	83700	80400
	-5	-20.6	86100	83500	80700	78000	75200	72300
	-10	-23.3	77000	74600	72200	69800	67400	64900
	-15	-26.1	68500	66500	64400	62300	60200	58000
	-20	-28.9	60700	58900	57200	55300	53400	51600
	-25	-31.7	53700	52100	50600	49000	47400	45700
	-30	-34.4	47100	45900	44500	43200	41800	40200
	-35	-37.2	41400	40200	39100	37900	36500	35300
	-40	-40.0	36100	35100	34100	33000	31800	30700

## Standard Models

Model BEZA	Compressor Model A1 Refrigerant	Compressor Model A1/A2I Refrigerants	Power Supply	Compressor		Condenser Fan Motor			Unit		
				RLA	LRA	Quantity	Watts	FLA	MCA	MOP	
BEZA007H8-*	S2D	ZB06KAE-PFV	YB06KAE-PFV	208-230/1/60	6.0	36.0	1	100**	1.0	8.5	15
	T3D	ZB06KAE-TF5	YB06KAE-TF5	208-230/3/60	4.8	37.8	1	100**	1.0	7.0	15
BEZA008H8-*	S2D	ZB07KAE-PFV	YB07KAE-PFV	208-230/1/60	6.3	48.0	1	100**	1.0	8.9	15
	T3D	ZB07KAE-TF5	YB07KAE-TF5	208-230/3/60	5.2	37.8	1	100**	1.0	7.5	15
BEZA009H8-*	S2D	ZB08KAE-PFV	YB08KAE-PFV	208-230/1/60	8.0	47.2	1	100**	1.0	11.0	15
	T3D	ZB08KAE-TF5	YB08KAE-TF5	208-230/3/60	5.3	37.8	1	100**	1.0	7.6	15
BEZA010H8-*	S2D	ZS09KAE-PFV	YS09KAE-PFV	208-230/1/60	10.0	40.3	1	240	1.1	13.6	20
	T3D	ZS09KAE-TF5	YS09KAE-TF5	208-230/3/60	8.0	55.4	1	240	1.1	11.1	15
	T4D	ZS09KAE-TFD	YS09KAE-TFD	460/3/60	3.8	28	1	240	0.6	5.4	15
BEZA011H8-*	S2D	ZS11KAE-PFV	YS11KAE-PFV	208-230/1/60	12.6	55	1	240	1.1	16.9	25
	T3D	ZS11KAE-TF5	YS11KAE-TF5	208-230/3/60	10.4	58	1	240	1.1	14.1	20
	T4D	ZS11KAE-TFD	YS11KAE-TFD	460/3/60	4.3	28	1	240	0.6	6.0	15
BEZA015H8-*	S2D	ZS13KAE-PFV	YS12KAE-PFV	208-230/1/60	12.0	56	1	240	1.1	16.1	25
	T3D	ZS13KAE-TF5	YS12KAE-TF5	208-230/3/60	9.7	58	1	240	1.1	13.2	20
	T4D	ZS13KAE-TFD	YS12KAE-TFD	460/3/60	4.8	29	1	240	0.6	6.6	15
	T5D	ZS13KAE-TFE	YS12KAE-TFE	575/3/60	3.6	24.5	1	240	0.5	5.0	15
BEZA020H8-*	S2D	ZS15KAE-PFV	YS14KAE-PFV	208-230/1/60	15.7	68	1	240	1.1	20.7	35
	T3D	ZS15KAE-TF5	YS14KAE-TF5	208-230/3/60	10.6	58	1	240	1.1	14.4	25
	T4D	ZS15KAE-TFD	YS14KAE-TFD	460/3/60	5.4	29	1	240	0.6	7.4	15
	T5D	ZS15KAE-TFE	YS14KAE-TFE	575/3/60	3.9	24	1	240	0.5	5.4	15
BEZA025H8-*	S2D	ZS19KAE-PFV	YS16KAE-PFV	208-230/1/60	18.0	75	1	400	2.1	24.6	40
	T3D	ZS19KAE-TF5	YS16KAE-TF5	208-230/3/60	13.7	73	1	400	2.1	19.2	30
	T4D	ZS19KAE-TFD	YS16KAE-TFD	460/3/60	6.5	38	1	400	1.1	9.2	15
	T5D	ZS19KAE-TFE	YS16KAE-TFE	575/3/60	4.3	28	1	400	0.9	6.3	15
BEZA030H8-*	S2D	ZS21KAE-PFV	YS21KAE-PFV	208-230/1/60	23.2	112	1	400	2.1	31.1	50
	T3D	ZS21KAE-TF5	YS21KAE-TF5	208-230/3/60	15.2	93	1	400	2.1	21.1	35
	T4D	ZS21KAE-TFD	YS21KAE-TFD	460/3/60	6.9	48	1	400	1.1	9.7	15
	T5D	ZS21KAE-TFE	YS21KAE-TFE	575/3/60	5.8	33	1	400	0.9	8.2	15
BEZA035H8-*	S2D	ZS26KAE-PFV	YS24KAE-PFV	208-230/1/60	23.6	104	1	400	2.1	31.6	50
	T3D	ZS26KAE-TF5	YS24KAE-TF5	208-230/3/60	15.5	93	1	400	2.1	21.5	35
	T4D	ZS26KAE-TFD	YS24KAE-TFD	460/3/60	6.9	48	1	400	1.1	9.7	15
	T5D	ZS26KAE-TFE	YS24KAE-TFE	575/3/60	6.4	38	1	400	0.9	8.9	15
BEZA040H8-*	S2D	ZS29KAE-PFV	YS26KAE-PFV	208-230/1/60	26.1	137	1	400	2.1	34.7	60
	T3D	ZS29KAE-TF5	YS26KAE-TF5	208-230/3/60	20.5	114	1	400	2.1	27.7	45
	T4D	ZS29KAE-TFD	YS26KAE-TFD	460/3/60	9.4	58	1	400	1.1	12.9	20
	T5D	ZS29KAE-TFE	YS26KAE-TFE	575/3/60	5.8	43	1	400	0.9	8.2	15
BEZA045H8-*	S2D	ZS33KAE-PFV	YS30KAE-PFV	208-230/1/60	25.6	146	1	400	2.1	34.1	60
	T3D	ZS33KAE-TF5	YS30KAE-TF5	208-230/3/60	22.3	114	1	400	2.1	30.0	50
	T4D	ZS33KAE-TFD	YS30KAE-TFD	460/3/60	10.0	52	1	400	1.1	13.6	20
	T5D	ZS33KAE-TFE	YS30KAE-TFE	575/3/60	6.9	39.5	1	400	0.9	9.5	15
BEZA050H8-*	S2D	ZB38KCE-PFV	YB34KAE-PFV	208-230/1/60	31.1	175	1	400	2.1	41.0	70
	T3D	ZB38KCE-TF5	YB34KAE-TF5	208-230/3/60	22.1	128	1	400	2.1	29.7	50
	T4D	ZB38KCE-TFD	YB34KAE-TFD	460/3/60	9.6	63	1	400	1.1	13.1	20
	T5D	ZB38KCE-TFE	YB34KAE-TFE	575/3/60	7.1	50	1	400	0.9	9.8	15
BEZA060H8-*	T3D	ZB45KCE-TF5	YB40KAE-TF5	208-230/3/60	22.5	156	1	400	2.1	30.2	50
	T4D	ZB45KCE-TFD	YB40KAE-TFD	460/3/60	11.5	75	1	400	1.1	15.5	25
	T5D	ZB45KCE-TFE	YB40KAE-TFE	575/3/60	7.9	54	1	400	0.9	10.8	15
BEZA061H8-*	T3D	ZB48KCE-TF5	YB44KAE-TF5	208-230/3/60	25.4	164	1	400	2.1	33.9	50
	T4D	ZB48KCE-TFD	YB44KAE-TFD	460/3/60	13.6	100	1	400	1.1	18.1	30
	T5D	ZB48KCE-TFE	YB44KAE-TFE	575/3/60	10.1	78	1	400	0.9	13.5	20
BEZA070H8-*	T3D	ZB57KCE-TF5	YB50KAE-TF5	208-230/3/60	35.5	224	2	800	4.2	48.6	80
	T4D	ZB57KCE-TFD	YB50KAE-TFD	460/3/60	15.2	99	2	800	2.2	21.2	35
	T5D	ZB57KCE-TFE	YB50KAE-TFE	575/3/60	11.6	82.4	2	800	1.8	16.3	25
BEZA076H8-*	T3D	ZB66K5E-TFC	YB56KAE-TFC	208-230/3/60	39.3	225	2	800	4.2	53.3	90
	T4D	ZB66K5E-TFD	YB56KAE-TFD	460/3/60	17.3	114	2	800	2.2	23.8	40
	T5D	ZB66K5E-TFE	YB56KAE-TFE	575/3/60	14.3	80	2	800	1.8	19.7	30
BEZA085H8-*	T3D	ZB76K5E-TFC	YB68KAE-TFC	208-230/3/60	43.0	239	2	800	4.2	58.0	100
	T4D	ZB76K5E-TFD	YB68KAE-TFD	460/3/60	20.7	125	2	800	2.2	28.1	45
	T5D	ZB76K5E-TFE	YB68KAE-TFE	575/3/60	14.6	80	2	800	1.8	20.1	30
BEZA110H8-*	T3D	ZB95K5E-TWC	YB83KAE-TWC	208-230/3/60	52.9	298	2	1560	7.2	73.3	125
	T4D	ZB95K5E-TFD	YB83KAE-TFD	460/3/60	25.0	150	2	1560	3.4	34.7	50
	T5D	ZB95K5E-TFE	YB83KAE-TFE	575/3/60	20.8	123	2	1560	2.8	28.8	45
BEZA150H8-*	T3D	ZB114K5E-TWC	YB100KAE-TWC	208-230/3/60	63.0	321	2	1560	7.2	86.0	125
	T4D	ZB114K5E-TFD	YB100KAE-TFD	460/3/60	27.9	179	2	1560	3.4	38.3	60
	T5D	ZB114K5E-TWE	YB100KAE-TFE	575/3/60	22.4	132	2	1560	2.8	30.8	50

\* I = Indoor, H = Outdoor. Above listed RLA value is based on UL rating method and may differ from published compressor RLA data.

\*\* SMARTSPEED EC Motor Standard

table continues on next page >>>

## Standard Models (cont'd)

Model BEZA	Compressor Model A1 Refrigerant	Compressor Model A1/A21 Refrigerants	Power Supply	Compressor		Condenser Fan Motor			Unit		
				RLA	LRA	Quantity	Watts	FLA	MCA	MOP	
BEZA008L8-*	S2D	ZF03KAE-PFV	YF03KAE-PFV	208-230/1/60	6.4	42.6	1	100**	1.0	9.0	15
	T3D	ZF03KAE-TF5	YF03KAE-TF5	208-230/3/60	4.1	31.7	1	100**	1.0	6.1	15
BEZA010L8-*	S2D	ZF04KAE-PFV	YF04KAE-PFV	208-230/1/60	7.4	40	1	100**	1.0	10.3	15
	T3D	ZF04KAE-TF5	YF04KAE-TF5	208-230/3/60	6.6	55	1	100**	1.0	9.3	15
BEZA015L8-*	S2D	ZF05KAE-PFV	YF05KAE-PFV	208-230/1/60	8.7	55	1	100**	1.0	11.9	20
	T3D	ZF05KAE-TF5	YF05KAE-TF5	208-230/3/60	7.5	58	1	100**	1.0	10.4	15
BEZA020L8-*	S2D	ZF07KAE-PFV	YF07KAE-PFV	208-230/1/60	13.9	75	1	100**	1.0	18.4	30
	T3D	ZF07KAE-TF5	YF07KAE-TF5	208-230/3/60	8.6	58	1	100**	1.0	11.8	20
BEZA025L8-*	S2D	ZF08KAE-PFV	YF06KSE-PFV	208-230/1/60	16.4	73	1	240	1.1	21.6	35
	T3D	ZF08KAE-TF5	YF06KSE-TF5	208-230/3/60	9.6	63	1	240	1.1	13.1	20
	T4D	ZF08KAE-TFD	YF06KSE-TFD	460/3/60	5.0	31	1	240	0.6	6.9	15
BEZA030L8-*	S2D	ZF09KAE-PFV	YF07KSE-PFV	208-230/1/60	15.4	88	1	240	1.1	20.4	35
	T3D	ZF09KAE-TF5	YF07KSE-TF5	208-230/3/60	9.9	77	1	240	1.1	13.5	20
	T4D	ZF09KAE-TFD	YF07KSE-TFD	460/3/60	5.0	39	1	240	0.6	6.9	15
	T5D	ZF09KAE-TFE	YF07KSE-TFE	575/3/60	4.3	31	1	240	0.5	5.9	15
BEZA035L8-*	S2D	ZF11KAE-PFV	YF09KSE-PFV	208-230/1/60	20.7	109	1	240	1.1	27.0	45
	T3D	ZF11KAE-TF5	YF09KSE-TF5	208-230/3/60	12.7	88	1	240	1.1	17.0	25
	T4D	ZF11KAE-TFD	YF09KSE-TFD	460/3/60	6.4	44	1	240	0.6	8.6	15
	T5D	ZF11KAE-TFE	YF09KSE-TFE	575/3/60	4.6	34	1	240	0.5	6.3	15
BEZA045L8-*	S2D	ZF13KAE-PFV	YF10KAE-PFV	208-230/1/60	25.0	129	1	400	2.1	33.4	50
	T3D	ZF13KAE-TF5	YF10KAE-TF5	208-230/3/60	13.8	99	1	400	2.1	19.4	30
	T4D	ZF13KAE-TFD	YF10KAE-TFD	460/3/60	7.1	49.5	1	400	1.1	10.0	15
	T5D	ZF13KAE-TFE	YF10KAE-TFE	575/3/60	7.1	40	1	400	0.9	9.8	15
BEZA055L8-*	S2D	ZF15KAE-PFV	YF13KAE-PFV	208-230/1/60	27.9	169	1	400	2.1	37.0	60
	T3D	ZF15KAE-TF5	YF13KAE-TF5	208-230/3/60	18.9	123	1	400	2.1	25.7	40
	T4D	ZF15KAE-TFD	YF13KAE-TFD	460/3/60	8.9	62	1	400	1.1	12.2	20
	T5D	ZF15KAE-TFE	YF13KAE-TFE	575/3/60	6.4	50	1	400	0.9	8.9	15
BEZA060L8-*	T3D	ZF18KAE-TF5	YF15KAE-TF5	208-230/3/60	21.8	156	1	400	2.1	29.4	50
	T4D	ZF18KAE-TFD	YF15KAE-TFD	460/3/60	9.0	75	1	400	1.1	12.4	20
	T5D	ZF18KAE-TFE	YF15KAE-TFE	575/3/60	7.9	54	1	400	0.9	10.8	15
BEZA075L8-*	T3D	ZF25KAE-TF5	YF19KAE-TF5	208-230/3/60	26.7	224	1	400	2.1	35.5	60
	T4D	ZF25KAE-TFD	YF19KAE-TFD	460/3/60	11.9	99	1	400	1.1	16.0	25
	T5D	ZF25KAE-TFE	YF19KAE-TFE	575/3/60	9.1	82.4	1	400	0.9	12.3	20
BEZA085L8-*	T3D	ZF28KAE-TFC	YF22KAE-TFC	208-230/3/60	30.4	199	1	400	2.1	40.1	70
	T4D	ZF28KAE-TFD	YF22KAE-TFD	460/3/60	14.4	121	1	400	1.1	19.1	30
	T5D	ZF28KAE-TFE	YF22KAE-TFE	575/3/60	11.4	68.9	1	400	0.9	15.2	25
BEZA100L8-*	T3D	ZF34K5E-TFC	YF26KAE-TFC	208-230/3/60	37.1	239	1	400	2.1	48.5	80
	T4D	ZF34K5E-TFD	YF26KAE-TFD	460/3/60	17.9	100	1	400	1.1	23.5	40
	T5D	ZF34K5E-TFE	YF26KAE-TFE	575/3/60	14.3	100	1	400	0.9	18.8	30
BEZA130L8-*	T3D	ZF41K5E-TFC	YF32KAE-TFC	208-230/3/60	42.1	248	2	800	4.2	56.8	90
	T4D	ZF41K5E-TFD	YF32KAE-TFD	460/3/60	19.3	125	2	800	2.2	26.3	45
	T5D	ZF41K5E-TFE	YF32KAE-TFE	575/3/60	15.6	100	2	800	1.8	21.3	35
BEZA150L8-*	T3D	ZF49K5E-TFC	YF38KAE-TFC	208-230/3/60	50.7	339	2	800	4.2	67.6	100
	T4D	ZF49K5E-TFD	YF38KAE-TFD	460/3/60	20.2	139	2	800	2.2	27.5	45
	T5D	ZF49K5E-TFE	YF38KAE-TFE	575/3/60	18.2	123	2	800	1.8	24.6	40
BEZA170L8-*	T3D	ZF54K5E-TFC	YF44KAE-TFC	208-230/3/60	58.7	423	2	1560	7.2	80.6	125
	T4D	ZF54K5E-TFD	YF44KAE-TFD	460/3/60	28.6	185	2	1560	3.4	39.2	60
	T5D	ZF54K5E-TFE	YF44KAE-TFE	575/3/60	22.9	145	2	1560	2.8	31.4	50

\* I = Indoor, H = Outdoor. Above listed RLA value is based on UL rating method and may differ from published compressor RLA data.

\*\* SMARTSPEED EC Motor Standard

## Models with Optional SMARTSPEED™ EC Motors

Model BEZA	Compressor Model A1 Refrigerant	Compressor Model A1/A2I Refrigerants	Power Supply	Compressor		ECM Condenser Fan Motor			Unit		
				RLA	LRA	Quantity	Watts	FLA	MCA	MOP	
BEZA010H8-*	S2D	ZS09KAE-PFV	YS09KAE-PFV	208-230/1/60	10.0	40.3	1	175	2.0	14.5	20
	T3D	ZS09KAE-TF5	YS09KAE-TF5	208-230/3/60	8.0	55.4	1	175	2.0	12.0	20
	T4D	ZS09KAE-TFD	YS09KAE-TFD	460/3/60	3.8	28	1	175	1.0	5.8	15
BEZA011H8-*	S2D	ZS11KAE-PFV	YS11KAE-PFV	208-230/1/60	12.6	55	1	175	2.0	17.8	30
	T3D	ZS11KAE-TF5	YS11KAE-TF5	208-230/3/60	10.4	58	1	175	2.0	15.0	25
	T4D	ZS11KAE-TFD	YS11KAE-TFD	460/3/60	4.3	28	1	175	1.0	6.4	15
BEZA015H8-*	S2D	ZS13KAE-PFV	YS12KAE-PFV	208-230/1/60	12.0	56	1	175	2.0	17.0	25
	T3D	ZS13KAE-TF5	YS12KAE-TF5	208-230/3/60	9.7	58	1	175	2.0	14.1	20
	T4D	ZS13KAE-TFD	YS12KAE-TFD	460/3/60	4.8	29	1	175	1.0	7.0	15
	T5D	ZS13KAE-TFE	YS12KAE-TFE	575/3/60	3.6	24.5	1	175	0.8	5.3	15
BEZA020H8-*	S2D	ZS15KAE-PFV	YS14KAE-PFV	208-230/1/60	15.7	68	1	175	2.0	21.6	35
	T3D	ZS15KAE-TF5	YS14KAE-TF5	208-230/3/60	10.6	58	1	175	2.0	15.3	25
	T4D	ZS15KAE-TFD	YS14KAE-TFD	460/3/60	5.4	29	1	175	1.0	7.8	15
	T5D	ZS15KAE-TFE	YS14KAE-TFE	575/3/60	3.9	24	1	175	0.8	5.7	15
BEZA025H8-*	S2D	ZS19KAE-PFV	YS16KAE-PFV	208-230/1/60	18.0	75	1	315	3.5	26.0	40
	T3D	ZS19KAE-TF5	YS16KAE-TF5	208-230/3/60	13.7	73	1	315	3.5	20.6	30
	T4D	ZS19KAE-TFD	YS16KAE-TFD	460/3/60	6.5	38	1	315	1.8	9.9	15
	T5D	ZS19KAE-TFE	YS16KAE-TFE	575/3/60	4.3	28	1	315	1.4	6.8	15
BEZA030H8-*	S2D	ZS21KAE-PFV	YS21KAE-PFV	208-230/1/60	23.2	112	1	315	3.5	32.5	50
	T3D	ZS21KAE-TF5	YS21KAE-TF5	208-230/3/60	15.2	93	1	315	3.5	22.5	35
	T4D	ZS21KAE-TFD	YS21KAE-TFD	460/3/60	6.9	48	1	315	1.8	10.4	15
	T5D	ZS21KAE-TFE	YS21KAE-TFE	575/3/60	5.8	33	1	315	1.4	8.7	15
BEZA035H8-*	S2D	ZS26KAE-PFV	YS24KAE-PFV	208-230/1/60	23.6	104	1	315	3.5	33.0	50
	T3D	ZS26KAE-TF5	YS24KAE-TF5	208-230/3/60	15.5	93	1	315	3.5	22.9	35
	T4D	ZS26KAE-TFD	YS24KAE-TFD	460/3/60	6.9	48	1	315	1.8	10.4	15
	T5D	ZS26KAE-TFE	YS24KAE-TFE	575/3/60	6.4	38	1	315	1.4	9.4	15
BEZA040H8-*	S2D	ZS29KAE-PFV	YS26KAE-PFV	208-230/1/60	26.1	137	1	315	3.5	36.1	60
	T3D	ZS29KAE-TF5	YS26KAE-TF5	208-230/3/60	20.5	114	1	315	3.5	29.1	45
	T4D	ZS29KAE-TFD	YS26KAE-TFD	460/3/60	9.4	58	1	315	1.8	13.6	20
	T5D	ZS29KAE-TFE	YS26KAE-TFE	575/3/60	5.8	43	1	315	1.4	8.7	15
BEZA045H8-*	S2D	ZS33KAE-PFV	YS30KAE-PFV	208-230/1/60	25.6	146	1	315	3.5	35.5	60
	T3D	ZS33KAE-TF5	YS30KAE-TF5	208-230/3/60	22.3	114	1	315	3.5	31.4	50
	T4D	ZS33KAE-TFD	YS30KAE-TFD	460/3/60	10.0	52	1	315	1.8	14.3	20
	T5D	ZS33KAE-TFE	YS30KAE-TFE	575/3/60	6.9	39.5	1	315	1.4	10.0	15
BEZA050H8-*	S2D	ZB38KCE-PFV	YB34KAE-PFV	208-230/1/60	31.1	175	1	315	3.5	42.4	70
	T3D	ZB38KCE-TF5	YB34KAE-TF5	208-230/3/60	22.1	128	1	315	3.5	31.1	50
	T4D	ZB38KCE-TFD	YB34KAE-TFD	460/3/60	9.6	63	1	315	1.8	13.8	20
	T5D	ZB38KCE-TFE	YB34KAE-TFE	575/3/60	7.1	50	1	315	1.4	10.3	15
BEZA060H8-*	T3D	ZB45KCE-TF5	YB40KAE-TF5	208-230/3/60	22.5	156	1	315	3.5	31.6	50
	T4D	ZB45KCE-TFD	YB40KAE-TFD	460/3/60	11.5	75	1	315	1.8	16.2	25
	T5D	ZB45KCE-TFE	YB40KAE-TFE	575/3/60	7.9	54	1	315	1.4	11.3	15
BEZA061H8-*	T3D	ZB48KCE-TF5	YB44KAE-TF5	208-230/3/60	25.4	164	1	315	3.5	35.3	60
	T4D	ZB48KCE-TFD	YB44KAE-TFD	460/3/60	13.6	100	1	315	1.8	18.8	30
	T5D	ZB48KCE-TFE	YB44KAE-TFE	575/3/60	10.1	78	1	315	1.4	14.0	20
BEZA070H8-*	T3D	ZB57KCE-TF5	YB50KAE-TF5	208-230/3/60	35.5	224	2	630	7.0	51.4	80
	T4D	ZB57KCE-TFD	YB50KAE-TFD	460/3/60	15.2	99	2	630	3.6	22.6	35
	T5D	ZB57KCE-TFE	YB50KAE-TFE	575/3/60	11.6	82.4	2	630	2.8	17.3	25
BEZA076H8-*	T3D	ZB66K5E-TFC	YB56KAE-TFC	208-230/3/60	39.3	225	2	630	7.0	56.1	90
	T4D	ZB66K5E-TFD	YB56KAE-TFD	460/3/60	17.3	114	2	630	3.6	25.2	40
	T5D	ZB66K5E-TFE	YB56KAE-TFE	575/3/60	14.3	80	2	630	2.8	20.7	35
BEZA085H8-*	T3D	ZB76K5E-TFC	YB68KAE-TFC	208-230/3/60	43.0	239	2	630	7.0	60.8	100
	T4D	ZB76K5E-TFD	YB68KAE-TFD	460/3/60	20.7	125	2	630	3.6	29.5	50
	T5D	ZB76K5E-TFE	YB68KAE-TFE	575/3/60	14.6	80	2	630	2.8	21.1	35
BEZA110H8-*	T3D	ZB95K5E-TWC	YB83KAE-TWC	208-230/3/60	52.9	298	2	1180	10.6	76.7	125
	T4D	ZB95K5E-TFD	YB83KAE-TFD	460/3/60	25.0	150	2	1180	5.8	37.1	60
	T5D	ZB95K5E-TFE	YB83KAE-TFE	575/3/60	20.8	123	2	1180	4.2	30.2	50
BEZA150H8-*	T3D	ZB114K5E-TWC	YB100KAE-TWC	208-230/3/60	63.0	321	2	1180	10.6	89.4	150
	T4D	ZB114K5E-TFD	YB100KAE-TFD	460/3/60	27.9	179	2	1180	5.8	40.7	60
	T5D	ZB114K5E-TWE	YB100KAE-TFE	575/3/60	22.4	132	2	1180	4.2	32.2	50

\* I = Indoor, H = Outdoor. Above listed RLA value is based on UL rating method and may differ from published compressor RLA data.

table continues on next page >>>

## Models with Optional SMARTSPEED™ EC Motors (cont'd)

Model BEZA	Compressor Model A1 Refrigerant	Compressor Model A1/A2I Refrigerants	Power Supply	Compressor		ECM Condenser Fan Motor			Unit		
				RLA	LRA	Quantity	Watts	FLA	MCA	MOP	
BEZA025L8-*	S2D	ZF08K4E-PFV	YF06KSE-PFV	208-230/1/60	16.4	73	1	175	2.0	22.5	35
	T3D	ZF08K4E-TF5	YF06KSE-TF5	208-230/3/60	9.6	63	1	175	2.0	14.0	20
	T4D	ZF08K4E-TFD	YF06KSE-TFD	460/3/60	5.0	31	1	175	1.0	7.3	15
BEZA030L8-*	S2D	ZF09K4E-PFV	YF07KSE-PFV	208-230/1/60	15.4	88	1	175	2.0	21.3	35
	T3D	ZF09K4E-TF5	YF07KSE-TF5	208-230/3/60	9.9	77	1	175	2.0	14.4	20
	T4D	ZF09K4E-TFD	YF07KSE-TFD	460/3/60	5.0	39	1	175	1.0	7.3	15
	T5D	ZF09K4E-TFE	YF07KSE-TFE	575/3/60	4.3	31	1	175	0.8	6.2	15
BEZA035L8-*	S2D	ZF11K4E-PFV	YF09KSE-PFV	208-230/1/60	20.7	109	1	175	2.0	27.9	45
	T3D	ZF11K4E-TF5	YF09KSE-TF5	208-230/3/60	12.7	88	1	175	2.0	17.9	30
	T4D	ZF11K4E-TFD	YF09KSE-TFD	460/3/60	6.4	44	1	175	1.0	9.0	15
	T5D	ZF11K4E-TFE	YF09KSE-TFE	575/3/60	4.6	34	1	175	0.8	6.6	15
BEZA045L8-*	S2D	ZF13K4E-PFV	YF10KAE-PFV	208-230/1/60	25.0	129	1	315	3.5	34.8	60
	T3D	ZF13K4E-TF5	YF10KAE-TF5	208-230/3/60	13.8	99	1	315	3.5	20.8	30
	T4D	ZF13K4E-TFD	YF10KAE-TFD	460/3/60	7.1	49.5	1	315	1.8	10.7	15
	T5D	ZF13K4E-TFE	YF10KAE-TFE	575/3/60	7.1	40	1	315	1.4	10.3	15
BEZA055L8-*	S2D	ZF15K4E-PFV	YF13KAE-PFV	208-230/1/60	27.9	169	1	315	3.5	38.4	60
	T3D	ZF15K4E-TF5	YF13KAE-TF5	208-230/3/60	18.9	123	1	315	3.5	27.1	45
	T4D	ZF15K4E-TFD	YF13KAE-TFD	460/3/60	8.9	62	1	315	1.8	12.9	20
	T5D	ZF15K4E-TFE	YF13KAE-TFE	575/3/60	6.4	50	1	315	1.4	9.4	15
BEZA060L8-*	T3D	ZF18K4E-TF5	YF15KAE-TF5	208-230/3/60	21.8	156	1	315	3.5	30.8	50
	T4D	ZF18K4E-TFD	YF15KAE-TFD	460/3/60	9.0	75	1	315	1.8	13.1	20
	T5D	ZF18K4E-TFE	YF15KAE-TFE	575/3/60	7.9	54	1	315	1.4	11.3	15
BEZA075L8-*	T3D	ZF25K4E-TF5	YF19KAE-TF5	208-230/3/60	26.7	224	1	315	3.5	36.9	60
	T4D	ZF25K4E-TFD	YF19KAE-TFD	460/3/60	11.9	99	1	315	1.8	16.7	25
	T5D	ZF25K4E-TFE	YF19KAE-TFE	575/3/60	9.1	82.4	1	315	1.4	12.8	20
BEZA085L8-*	T3D	ZF28K4E-TFC	YF22KAE-TFC	208-230/3/60	30.4	199	1	315	3.5	41.5	70
	T4D	ZF28K4E-TFD	YF22KAE-TFD	460/3/60	14.4	121	1	315	1.8	19.8	30
	T5D	ZF28K4E-TFE	YF22KAE-TFE	575/3/60	11.4	68.9	1	315	1.4	15.7	25
BEZA100L8-*	T3D	ZF34K5E-TFC	YF26KAE-TFC	208-230/3/60	37.1	239	1	315	3.5	49.9	80
	T4D	ZF34K5E-TFD	YF26KAE-TFD	460/3/60	17.9	100	1	315	1.8	24.2	40
	T5D	ZF34K5E-TFE	YF26KAE-TFE	575/3/60	14.3	100	1	315	1.4	19.3	30
BEZA130L8-*	T3D	ZF41K5E-TFC	YF32KAE-TFC	208-230/3/60	42.1	248	2	630	7.0	59.6	100
	T4D	ZF41K5E-TFD	YF32KAE-TFD	460/3/60	19.3	125	2	630	3.6	27.7	45
	T5D	ZF41K5E-TFE	YF32KAE-TFE	575/3/60	15.6	100	2	630	2.8	22.3	35
BEZA150L8-*	T3D	ZF49K5E-TFC	YF38KAE-TFC	208-230/3/60	50.7	339	2	630	7.0	70.4	120
	T4D	ZF49K5E-TFD	YF38KAE-TFD	460/3/60	20.2	139	2	630	3.6	28.9	45
	T5D	ZF49K5E-TFE	YF38KAE-TFE	575/3/60	18.2	123	2	630	2.8	25.6	40
BEZA170L8-*	T3D	ZF54K5E-TFC	YF44KAE-TFC	208-230/3/60	58.7	423	2	1180	10.6	84.0	125
	T4D	ZF54K5E-TFD	YF44KAE-TFD	460/3/60	28.6	185	2	1180	5.4	41.2	70
	T5D	ZF54K5E-TFE	YF44KAE-TFE	575/3/60	22.9	145	2	1180	4.2	32.8	50

\* I = Indoor, H = Outdoor. Above listed RLA value is based on UL rating method and may differ from published compressor RLA data.

**Annual Walk-In Energy Factor Ratings - High/Medium Temperature**

If a numerical value is listed in the table below, the following statement applies to that corresponding model: "This refrigeration system is designed and certified for use in walk-in cooler applications."

Model BEZA	Power Supply	Outdoor Models				Indoor Models			
		R404A	R407A	R448A	R407C	R404A	R407A	R448A	R407C
		R507		R449A		R507		R449A	
BEZA007H8-*	S2D	208-230/1/60	7.6	7.6	7.6	-	-	-	-
	T3D	208-230/3/60	7.6	7.6	7.6	-	-	-	-
BEZA008H8-*	S2D	208-230/1/60	7.6	7.6	7.6	5.61	5.61	5.61	5.61
	T3D	208-230/3/60	7.6	7.6	7.6	5.61	5.61	5.61	5.61
BEZA009H8-*	S2D	208-230/1/60	7.6	7.6	7.6	7.6	5.61	5.61	5.61
	T3D	208-230/3/60	7.6	7.6	7.6	7.6	5.61	5.61	5.61
BEZA010H8-*	S2D	208-230/1/60	7.6	7.6	7.6	-	-	-	-
	T3D	208-230/3/60	7.6	7.6	7.6	-	-	-	-
	T4D	460/3/60	7.6	7.6	7.6	-	-	-	-
BEZA011H8-*	S2D	208-230/1/60	7.6	7.6	7.6	-	5.61	5.61	-
	T3D	208-230/3/60	7.6	7.6	7.6	-	5.61	5.61	-
	T4D	460/3/60	7.6	7.6	7.6	-	5.61	5.61	-
BEZA015H8-*	S2D	208-230/1/60	7.6	7.6	7.6	7.6	5.61	5.61	5.61
	T3D	208-230/3/60	7.6	7.6	7.6	7.6	5.61	5.61	5.61
	T4D	460/3/60	7.6	7.6	7.6	7.6	5.61	5.61	5.61
	T5D	575/3/60	7.6	7.6	7.6	7.6	5.61	5.61	5.61
BEZA020H8-*	S2D	208-230/1/60	7.6	7.6	7.6	7.6	-	-	-
	T3D	208-230/3/60	7.6	7.6	7.6	7.6	-	-	-
	T4D	460/3/60	7.6	7.6	7.6	7.6	-	-	-
	T5D	575/3/60	7.6	7.6	7.6	7.6	-	-	-
BEZA025H8-*	S2D	208-230/1/60	7.6	7.6	7.6	7.6	5.61	5.61	5.61
	T3D	208-230/3/60	7.6	7.6	7.6	7.6	5.61	5.61	5.61
	T4D	460/3/60	7.6	7.6	7.6	7.6	5.61	5.61	5.61
	T5D	575/3/60	7.6	7.6	7.6	7.6	5.61	5.61	5.61
BEZA030H8-*	S2D	208-230/1/60	7.6	7.6	7.6	7.6	5.61	5.61	5.61
	T3D	208-230/3/60	7.6	7.6	7.6	7.6	5.61	5.61	5.61
	T4D	460/3/60	7.6	7.6	7.6	7.6	5.61	5.61	5.61
	T5D	575/3/60	7.6	7.6	7.6	7.6	5.61	5.61	5.61
BEZA035H8-*	S2D	208-230/1/60	7.6	7.6	7.6	7.6	5.61	5.61	5.61
	T3D	208-230/3/60	7.6	7.6	7.6	7.6	5.61	5.61	5.61
	T4D	460/3/60	7.6	7.6	7.6	7.6	5.61	5.61	5.61
	T5D	575/3/60	7.6	7.6	7.6	7.6	5.61	5.61	5.61
BEZA040H8-*	S2D	208-230/1/60	7.6	7.6	7.6	7.6	5.61	5.61	5.61
	T3D	208-230/3/60	7.6	7.6	7.6	7.6	5.61	5.61	5.61
	T4D	460/3/60	7.6	7.6	7.6	7.6	5.61	5.61	5.61
	T5D	575/3/60	7.6	7.6	7.6	7.6	5.61	5.61	5.61
BEZA045H8-*	S2D	208-230/1/60	7.6	7.6	7.6	7.6	5.61	5.61	5.61
	T3D	208-230/3/60	7.6	7.6	7.6	7.6	5.61	5.61	5.61
	T4D	460/3/60	7.6	7.6	7.6	7.6	5.61	5.61	5.61
	T5D	575/3/60	7.6	7.6	7.6	7.6	5.61	5.61	5.61
BEZA050H8-*	S2D	208-230/1/60	7.6	7.6	7.6	7.6	-	5.61	5.61
	T3D	208-230/3/60	7.6	7.6	7.6	7.6	-	5.61	5.61
	T4D	460/3/60	7.6	7.6	7.6	7.6	-	5.61	5.61
	T5D	575/3/60	7.6	7.6	7.6	7.6	-	5.61	5.61
BEZA060H8-*	T3D	208-230/3/60	7.6	7.6	7.6	7.6	5.61	5.61	5.61
	T4D	460/3/60	7.6	7.6	7.6	7.6	5.61	5.61	5.61
	T5D	575/3/60	7.6	7.6	7.6	7.6	5.61	5.61	5.61
BEZA061H8-*	T3D	208-230/3/60	7.6	7.6	7.6	7.6	-	5.61	5.61
	T4D	460/3/60	7.6	7.6	7.6	7.6	-	5.61	5.61
	T5D	575/3/60	7.6	7.6	7.6	-	5.61	5.61	
BEZA070H8-*	T3D	208-230/3/60	7.6	7.6	7.6	7.6	5.61	5.61	5.61
	T4D	460/3/60	7.6	7.6	7.6	7.6	5.61	5.61	5.61
	T5D	575/3/60	7.6	7.6	7.6	7.6	5.61	5.61	5.61
BEZA076H8-*	T3D	208-230/3/60	7.6	7.6	7.6	7.6	5.61	5.61	5.61
	T4D	460/3/60	7.6	7.6	7.6	7.6	5.61	5.61	5.61
	T5D	575/3/60	7.6	7.6	7.6	7.6	5.61	5.61	5.61
BEZA085H8-*	T3D	208-230/3/60	7.6	7.6	7.6	7.6	-	-	5.61
	T4D	460/3/60	7.6	7.6	7.6	7.6	-	-	5.61
	T5D	575/3/60	7.6	7.6	7.6	7.6	-	-	5.61
BEZA110H8-*	T3D	208-230/3/60	7.6	7.6	7.6	7.6	5.61	5.61	5.61
	T4D	460/3/60	7.6	7.6	7.6	7.6	5.61	5.61	5.61
	T5D	575/3/60	7.6	7.6	7.6	7.6	5.61	5.61	5.61
BEZA150H8-*	T3D	208-230/3/60	7.6	7.6	7.6	7.6	-	-	5.61
	T4D	460/3/60	7.6	7.6	7.6	7.6	-	-	5.61
	T5D	575/3/60	7.6	7.6	7.6	7.6	-	-	5.61

- = Non-compliant model

**Annual Walk-In Energy Factor Ratings - Low Temperature**

If a numerical value is listed in the table below, the following statement applies to that corresponding model: "This refrigeration system is designed and certified for use in walk-in freezer applications."

Model BEZA	Power Supply	Outdoor Models			Indoor Models		
		R404A R507	R407A	R448A R449A	R404A R507	R407A	R448A R449A
		BEZA008L8-*	S2D 208-230/1/60 T3D 208-230/3/60	2.88 2.88	- -	- -	2.03 2.03
BEZA010L8-*	S2D 208-230/1/60 T3D 208-230/3/60	2.93 2.93	2.91 2.91	2.92 2.92	2.10 2.10	- -	- -
BEZA015L8-*	S2D 208-230/1/60 T3D 208-230/3/60	2.98 2.98	2.96 2.96	2.97 2.97	2.17 2.17	2.13 2.13	2.15 2.15
BEZA020L8-*	S2D 208-230/1/60 T3D 208-230/3/60	3.1 3.1	3.08 3.08	3.08 3.08	- -	- -	- -
BEZA025L8-*	S2D 208-230/1/60 T3D 208-230/3/60 T4D 460/3/60	3.15 3.15 3.15	- 3.13 3.13	3.14 3.14 3.14	2.40 2.40 2.40	- - -	2.39 2.39 2.39
BEZA030L8-*	S2D 208-230/1/60 T3D 208-230/3/60 T4D 460/3/60 T5D 575/3/60	3.15 3.15 3.15 3.15	- 3.15 3.15 3.15	3.15 3.15 3.15 3.15	2.40 2.40 2.40 2.40	- - - -	2.40 2.40 2.40 2.40
BEZA035L8-*	S2D 208-230/1/60 T3D 208-230/3/60 T4D 460/3/60 T5D 575/3/60	3.15 3.15 3.15 3.15	- 3.15 3.15 3.15	3.15 3.15 3.15 3.15	2.40 2.40 2.40 2.40	- - - -	- 2.40 2.40 2.40
BEZA045L8-*	S2D 208-230/1/60 T3D 208-230/3/60 T4D 460/3/60 T5D 575/3/60	3.15 3.15 3.15 3.15	- 3.15 3.15 3.15	3.15 3.15 3.15 3.15	2.40 2.40 2.40 2.40	- 2.40 2.40 2.40	- 2.40 2.40 2.40
BEZA055L8-*	S2D 208-230/1/60 T3D 208-230/3/60 T4D 460/3/60 T5D 575/3/60	3.15 3.15 3.15 3.15	- 3.15 3.15 3.15	3.15 3.15 3.15 3.15	2.40 2.40 2.40 2.40	2.40 2.40 2.40 2.40	2.40 2.40 2.40 2.40
BEZA060L8-*	T3D 208-230/3/60 T4D 460/3/60 T5D 575/3/60	3.15 3.15 3.15	3.15 3.15 3.15	3.15 3.15 3.15	2.40 2.40 2.40	2.40 2.40 2.40	2.40 2.40 2.40
BEZA075L8-*	T3D 208-230/3/60 T4D 460/3/60 T5D 575/3/60	3.15 3.15 3.15	3.15 3.15 3.15	3.15 3.15 3.15	2.40 2.40 2.40	2.40 2.40 2.40	2.40 2.40 2.40
BEZA085L8-*	T3D 208-230/3/60 T4D 460/3/60 T5D 575/3/60	3.15 3.15 3.15	3.15 3.15 3.15	3.15 3.15 3.15	2.40 2.40 2.40	2.40 2.40 2.40	2.40 2.40 2.40
BEZA100L8-*	T3D 208-230/3/60 T4D 460/3/60 T5D 575/3/60	3.15 3.15 3.15	- - -	3.15 3.15 3.15	- - -	2.40 2.40 2.40	2.40 2.40 2.40
BEZA130L8-*	T3D 208-230/3/60 T4D 460/3/60 T5D 575/3/60	3.15 3.15 3.15	- - -	3.15 3.15 3.15	2.40 2.40 2.40	- - -	2.40 2.40 2.40
BEZA150L8-*	T3D 208-230/3/60 T4D 460/3/60 T5D 575/3/60	3.15 3.15 3.15	- - -	3.15 3.15 3.15	- - -	- - -	- - -
BEZA170L8-*	T3D 208-230/3/60 T4D 460/3/60 T5D 575/3/60	- - -	- - -	3.15 3.15 3.15	- - -	- - -	- - -

- = Non-compliant model

**Drawing A: 1 Fan Models, Chassis 1 and 2**

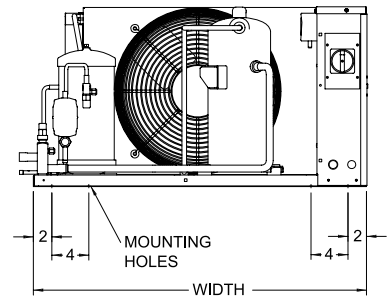
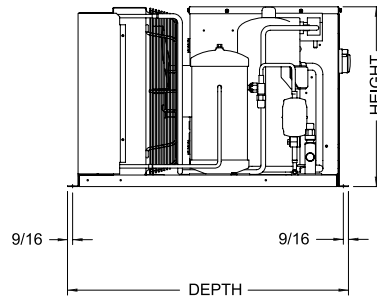
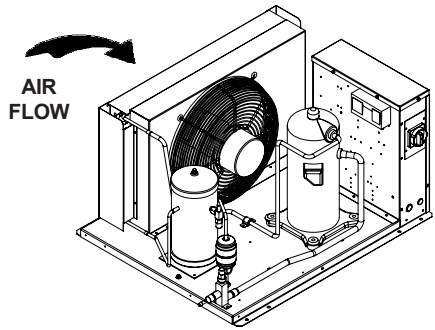

**INDOOR DIMENSIONS**

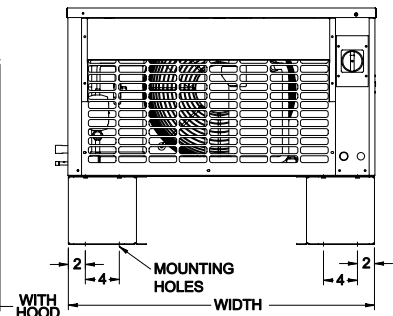
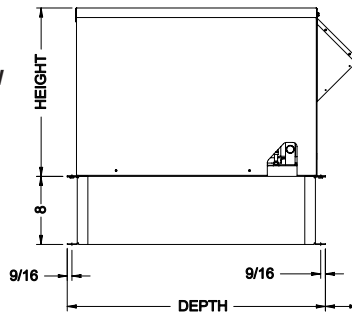
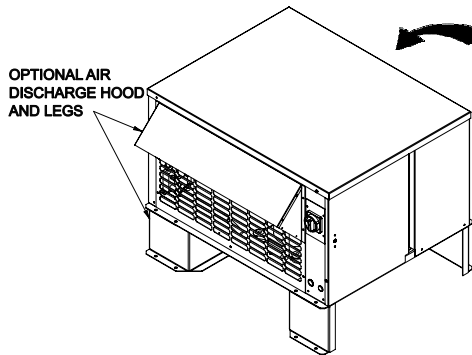

**OUTDOOR DIMENSIONS**

**NOTE: Discharge hood, legs and wind guard are optional components**

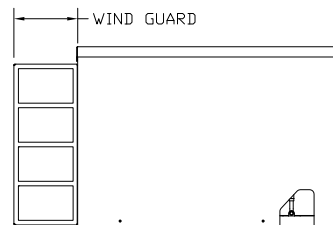
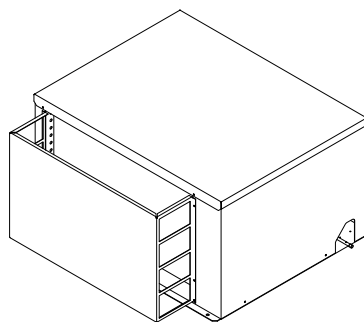

**REFER TO PAGE 29 FOR DIMENSIONAL DATA FOR SPECIFIC MODELS**

**Drawing B: 1 Fan Models, Chassis 3 and 4**

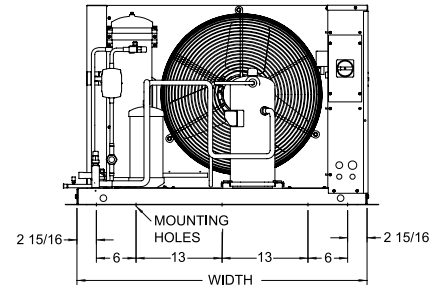
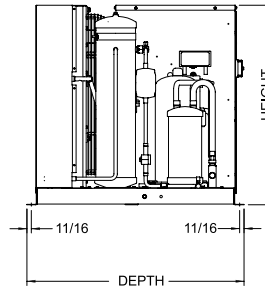
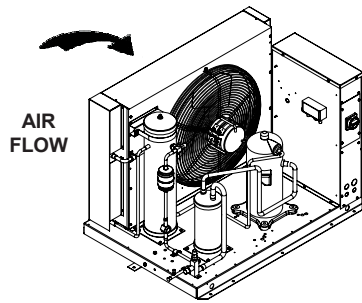

**INDOOR DIMENSIONS**

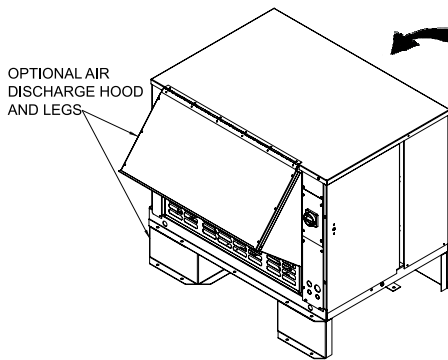

**AIR FLOW**

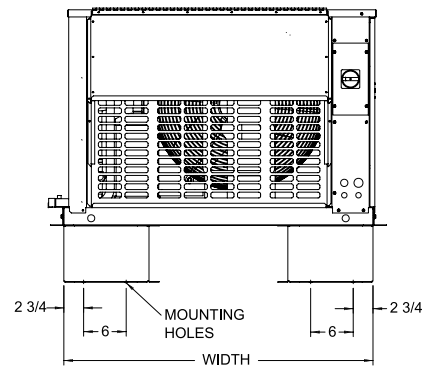
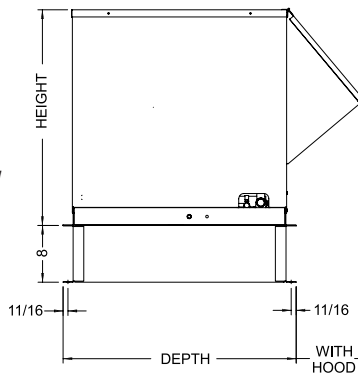

**OUTDOOR DIMENSIONS**

**NOTE: Discharge hood, legs and wind guard are optional components**

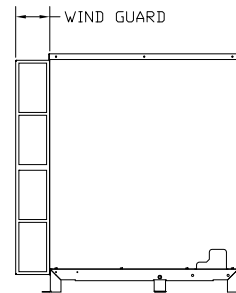
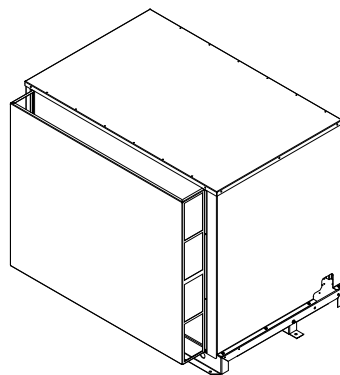

**REFER TO PAGE 29 FOR  
DIMENSIONAL DATA FOR SPECIFIC MODELS**

**Drawing C: 2 Fan Models, Chassis 5**

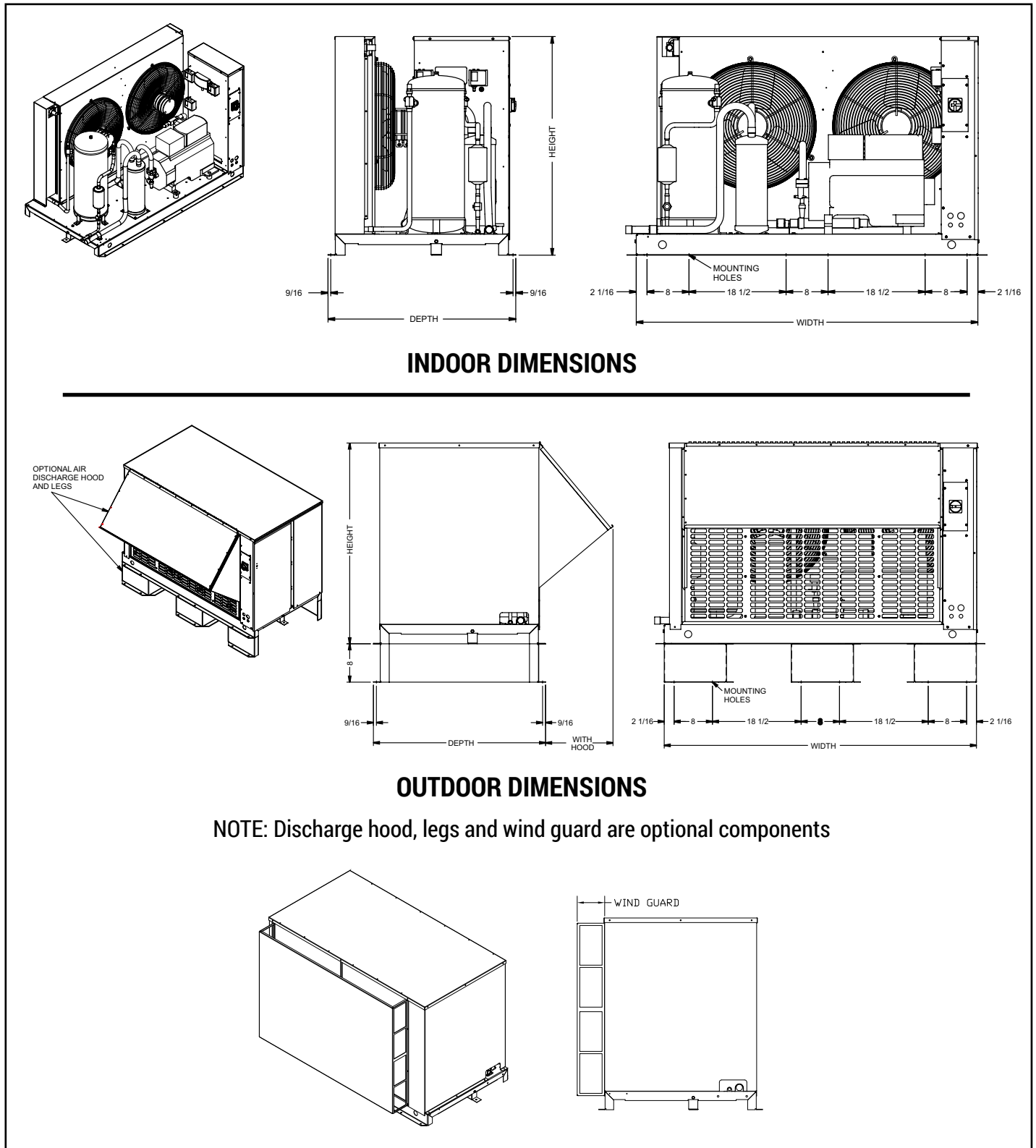

**REFER TO PAGE 29 FOR  
DIMENSIONAL DATA FOR SPECIFIC MODELS**

**Drawing D: 2 Fan Models, Chassis 6**

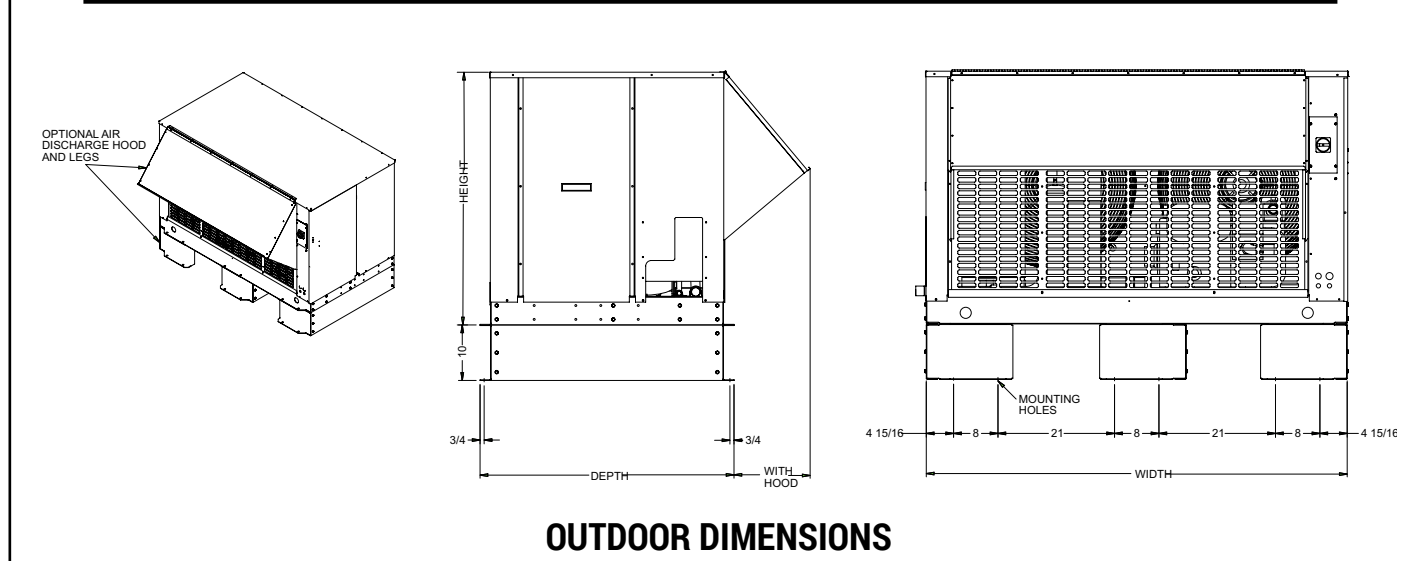
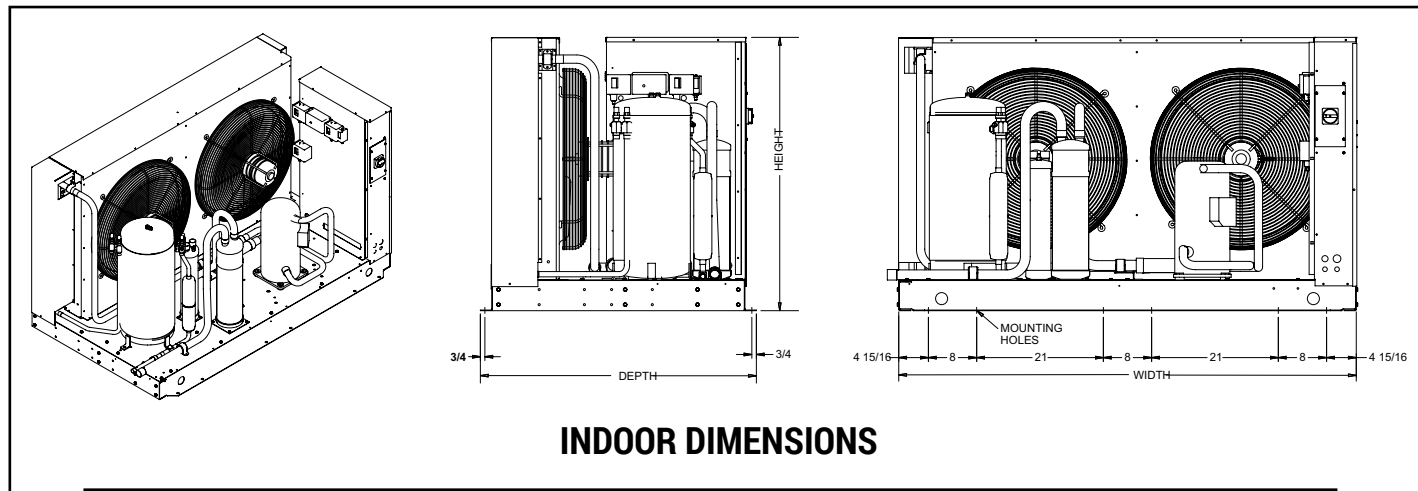

**NOTE: Discharge hood, legs and wind guard are optional components**

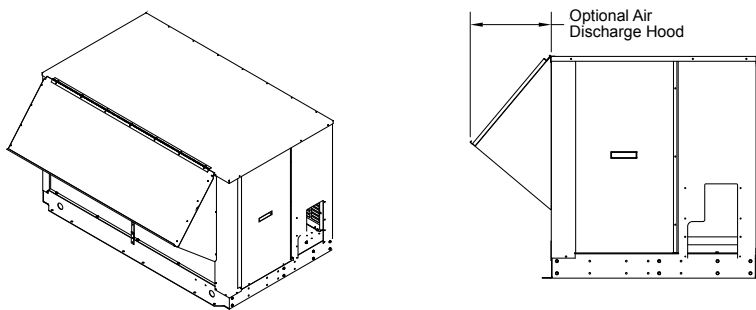

**REFER TO PAGE 29 FOR DIMENSIONAL DATA FOR SPECIFIC MODELS**

# DIMENSIONAL DATA

# BEZ - SCROLL CONDENSING UNITS

Model BEZA	Chassis (see details below)	Outdoor Models								Indoor Models					
		Width		Depth				Height		Width		Depth		Height	
				Base		with Hood									
		Inches	mm	Inches	mm	Inches	mm	Inches	mm	Inches	mm	Inches	mm	Inches	mm
BEZA007H8	1	24 7/8	632	30 3/8	772	34 3/8	873	19 3/8	492	24 5/8	625	30 3/8	772	19	483
BEZA008H8		24 7/8	632	30 3/8	772	34 3/8	873	19 3/8	492	24 5/8	625	30 3/8	772	19	483
BEZA009H8		24 7/8	632	30 3/8	772	34 3/8	873	19 3/8	492	24 5/8	625	30 3/8	772	19	483
BEZA010H8	2	36 3/8	924	30 3/8	772	34 3/8	873	19 7/8	505	36 3/8	924	30 3/8	772	19 1/2	495
BEZA011H8		36 3/8	924	30 3/8	772	34 3/8	873	19 7/8	505	36 3/8	924	30 3/8	772	19 1/2	495
BEZA015H8		36 3/8	924	30 3/8	772	34 3/8	873	19 7/8	505	36 3/8	924	30 3/8	772	19 1/2	495
BEZA020H8		36 3/8	924	30 3/8	772	34 3/8	873	19 7/8	505	36 3/8	924	30 3/8	772	19 1/2	495
BEZA025H8	3	43 7/8	1114	32 7/8	835	43	1092	30 3/8	772	43 7/8	1114	32 7/8	835	30 1/16	767
BEZA030H8		43 7/8	1114	32 7/8	835	43	1092	30 3/8	772	43 7/8	1114	32 7/8	835	30 3/16	767
BEZA035H8		43 7/8	1114	32 7/8	835	43	1092	30 3/8	772	43 7/8	1114	32 7/8	835	30 3/16	767
BEZA040H8		43 7/8	1114	32 7/8	835	43	1092	30 3/8	772	43 7/8	1114	32 7/8	835	30 3/16	767
BEZA045H8		43 7/8	1114	32 7/8	835	43	1092	30 3/8	772	43 7/8	1114	32 7/8	835	30 3/16	767
BEZA050H8		43 7/8	1114	32 7/8	835	43	1092	30 3/8	772	43 7/8	1114	32 7/8	835	30 3/16	767
BEZA060H8	4	52 1/8	1324	35 7/8	911	43	1092	41 7/8	1064	52 1/8	1324	35 7/8	911	41 11/16	1059
BEZA061H8		52 1/8	1324	35 7/8	911	43	1092	41 7/8	1064	52 1/8	1324	35 7/8	911	41 11/16	1059
BEZA070H8	5	65 1/8	1654	35 7/8	911	43	1092	41 7/8	1064	65 1/8	1654	35 7/8	911	41 11/16	1059
BEZA076H8		65 1/8	1654	35 7/8	911	43	1092	41 7/8	1064	65 1/8	1654	35 7/8	911	41 11/16	1059
BEZA085H8		65 1/8	1654	35 7/8	911	43	1092	41 7/8	1064	65 1/8	1654	35 7/8	911	41 11/16	1059
BEZA110H8	6	75 7/8	1927	45 3/4	1162	59	1511	45 1/2	1156	75 7/8	1927	45 3/4	1162	45 17/32	1156
BEZA150H8		75 7/8	1927	45 3/4	1162	59	1511	45 1/2	1156	75 7/8	1927	45 3/4	1162	45 17/32	1156
BEZA008L8	1	24 7/8	632	30 3/8	772	34 3/8	873	19 3/8	492	24 5/8	625	30 3/8	772	19	483
BEZA010L8		24 7/8	632	30 3/8	772	34 3/8	873	19 3/8	492	24 5/8	625	30 3/8	772	19	483
BEZA015L8		24 7/8	632	30 3/8	772	34 3/8	873	19 3/8	492	24 5/8	625	30 3/8	772	19	483
BEZA020L8		24 7/8	632	30 3/8	772	34 3/8	873	19 3/8	492	24 5/8	625	30 3/8	772	19	483
BEZA025L8	2	36 3/8	924	30 3/8	772	34 3/8	873	19 7/8	505	36 3/8	924	30 3/8	772	19 1/2	495
BEZA030L8		36 3/8	924	30 3/8	772	34 3/8	873	19 7/8	505	36 3/8	924	30 3/8	772	19 1/2	495
BEZA035L8		36 3/8	924	30 3/8	772	34 3/8	873	19 7/8	505	36 3/8	924	30 3/8	772	19 1/2	495
BEZA045L8	3	43 7/8	1114	32 7/8	835	43	1092	30 3/8	772	43 7/8	1114	32 7/8	835	30 3/16	767
BEZA055L8		43 7/8	1114	32 7/8	835	43	1092	30 3/8	772	43 7/8	1114	32 7/8	835	30 3/16	767
BEZA060L8		43 7/8	1114	32 7/8	835	43	1092	30 3/8	772	43 7/8	1114	32 7/8	835	30 3/16	767
BEZA075L8	4	52 1/8	1324	35 7/8	911	43	1092	41 7/8	1064	52 1/8	1324	35 7/8	911	41 11/16	1059
BEZA085L8		52 1/8	1324	35 7/8	911	43	1092	41 7/8	1064	52 1/8	1324	35 7/8	911	41 11/16	1059
BEZA100L8		52 1/8	1324	35 7/8	911	43	1092	41 7/8	1064	52 1/8	1324	35 7/8	911	41 11/16	1059
BEZA130L8	5	65 1/8	1654	35 7/8	911	43	1092	41 7/8	1064	65 1/8	1654	35 7/8	911	41 11/16	1059
BEZA150L8		65 1/8	1654	35 7/8	911	43	1092	41 7/8	1064	65 1/8	1654	35 7/8	911	41 11/16	1059
BEZA170L8	6	75 7/8	1927	45 3/4	1162	59	1511	45 1/2	1156	75 7/8	1927	45 3/4	1162	45 17/32	1156

Chassis	Drawing	See Page #
1	A	25
2	A	25
3	B	26
4	B	26
5	C	27
6	D	28

# SPECIFICATIONS

# BEZ - SCROLL CONDENSING UNITS

Model BEZA	Unit Connections				R404A Receiver Capacity 90% Full *		Approx. Shipping Weight			
	Suction (OD)		Liquid (OD)		Lbs.	Kgs	Outdoor Models		Indoor Models	
	Inches	mm	Inches	mm			Lbs.	Kgs	Lbs.	Kgs
BEZA007H8	5/8	16	3/8	10	5.4	2.4	183	83	161	73
BEZA008H8	5/8	16	3/8	10	5.4	2.4	188	85	167	76
BEZA009H8	5/8	16	3/8	10	5.4	2.4	188	85	167	76
BEZA010H8	5/8	16	3/8	10	11	4.9	285	129	265	120
BEZA011H8	5/8	16	3/8	10	11	4.9	285	129	265	120
BEZA015H8	7/8	22	3/8	10	11	4.9	285	129	265	120
BEZA020H8	7/8	22	3/8	10	11	4.9	300	136	280	127
BEZA025H8	7/8	22	1/2	13	22	10.0	405	184	370	168
BEZA030H8	7/8	22	1/2	13	22	10.0	410	186	375	170
BEZA035H8	7/8	22	1/2	13	22	10.0	415	188	380	172
BEZA040H8	1 1/8	29	1/2	13	22	10.0	420	191	390	177
BEZA045H8	1 1/8	29	1/2	13	22	10.0	425	193	390	177
BEZA050H8	1 1/8	29	1/2	13	22	10.0	425	193	390	177
BEZA060H8	1 1/8	29	5/8	16	30	13.8	470	213	430	195
BEZA061H8	1 1/8	29	5/8	16	30	13.6	510	231	465	211
BEZA070H8	1 3/8	35	5/8	16	54	24.5	625	283	570	259
BEZA076H8	1 3/8	35	5/8	16	54	24.5	635	288	580	263
BEZA085H8	1 3/8	35	5/8	16	54	24.5	645	293	590	268
BEZA110H8	1 3/8	35	7/8	22	76	34.5	745	338	690	313
BEZA150H8	1 5/8	41	7/8	22	76	34.5	845	383	790	358
BEZA008L8	5/8	16	3/8	10	5.4	2.4	205	93	185	84
BEZA010L8	5/8	16	3/8	10	5.4	2.4	205	93	185	84
BEZA015L8	5/8	16	3/8	10	5.4	2.4	210	95	190	86
BEZA020L8	7/8	22	3/8	10	11	4.9	315	143	290	132
BEZA025L8	7/8	22	3/8	10	14	6.3	335	152	310	141
BEZA030L8	7/8	22	3/8	10	14	6.3	425	193	390	177
BEZA035L8	7/8	22	1/2	13	14	6.3	430	195	400	181
BEZA045L8	1 1/8	29	1/2	13	22	10.0	435	197	400	181
BEZA055L8	1 1/8	29	1/2	13	22	10.0	440	200	400	181
BEZA060L8	1 1/8	29	1/2	13	22	10.0	485	220	450	204
BEZA075L8	1 3/8	35	5/8	16	30	13.8	495	225	460	209
BEZA085L8	1 3/8	35	5/8	16	30	13.6	525	238	480	218
BEZA100L8	1 3/8	35	5/8	16	30	13.6	545	247	500	227
BEZA130L8	1 3/8	35	5/8	16	54	24.5	725	329	670	304
BEZA150L8	1 5/8	35	5/8	16	54	24.5	745	338	690	313
BEZA170L8	1 5/8	41	7/8	22	76	34.5	955	433	900	408

**\* NOTE ON ALTERNATE REFRIGERANTS:**

\* PUBLISHED RECEIVER CAPACITY IS BASED ON **R404A** ON MODELS USING "8" AS REFRIGERANT CODE.  
FOR ALTERNATE REFRIGERANTS, MULTIPLY **R404A** VALUE BY THE APPROPRIATE VALUE BELOW:

<b>R407A</b>	<b>R407C</b>	<b>R448A</b>	<b>R449A</b>	<b>R507</b>	<b>R22</b>
1.10	1.10	1.05	1.05	1.00	1.15

208-230/1/60 Unit with 230V Air Defrost Evaporator

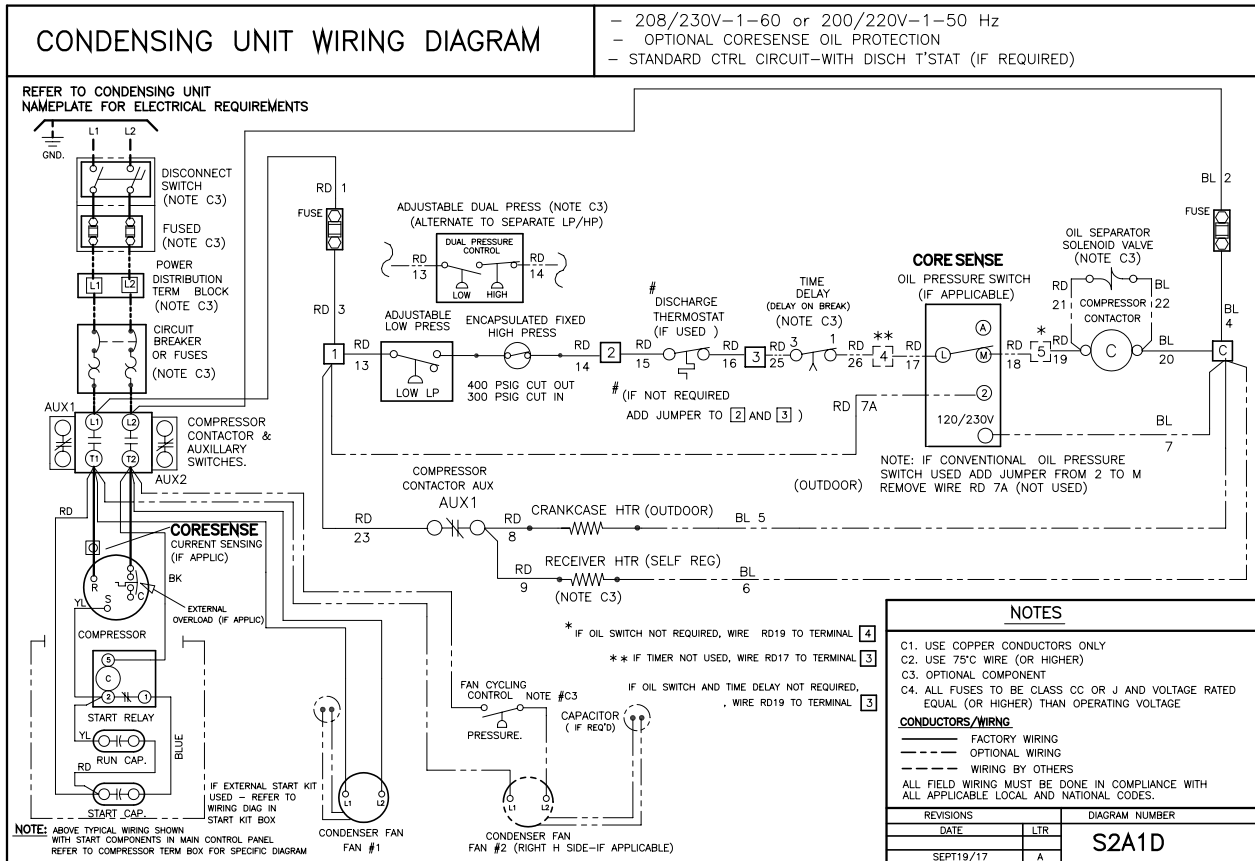

### TYPICAL EVAPORATOR WIRING: FOR SINGLE AIR DEFROST EVAPORATOR- SINGLE POINT

FOR USE WITH: 208/230-1-60, 200/220-1-50 OR 208/230-3-60, 200/220-3-50 CONDENSING UNITS  
 WITH OR WITHOUT DEFROST TIME CLOCK AND FOR TOTAL EVAP FAN AMPS NOT EXCEEDING 12A

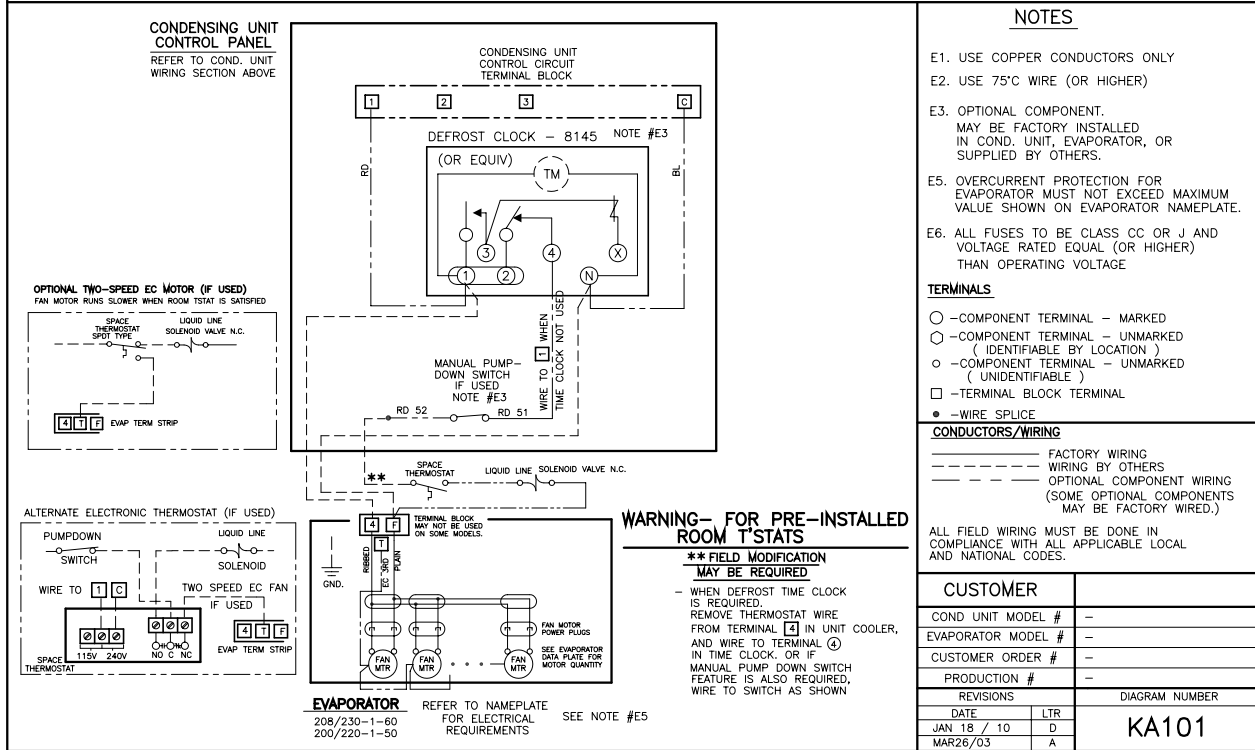

208-230/3/60 Unit with 230V Electric Defrost Evaporator

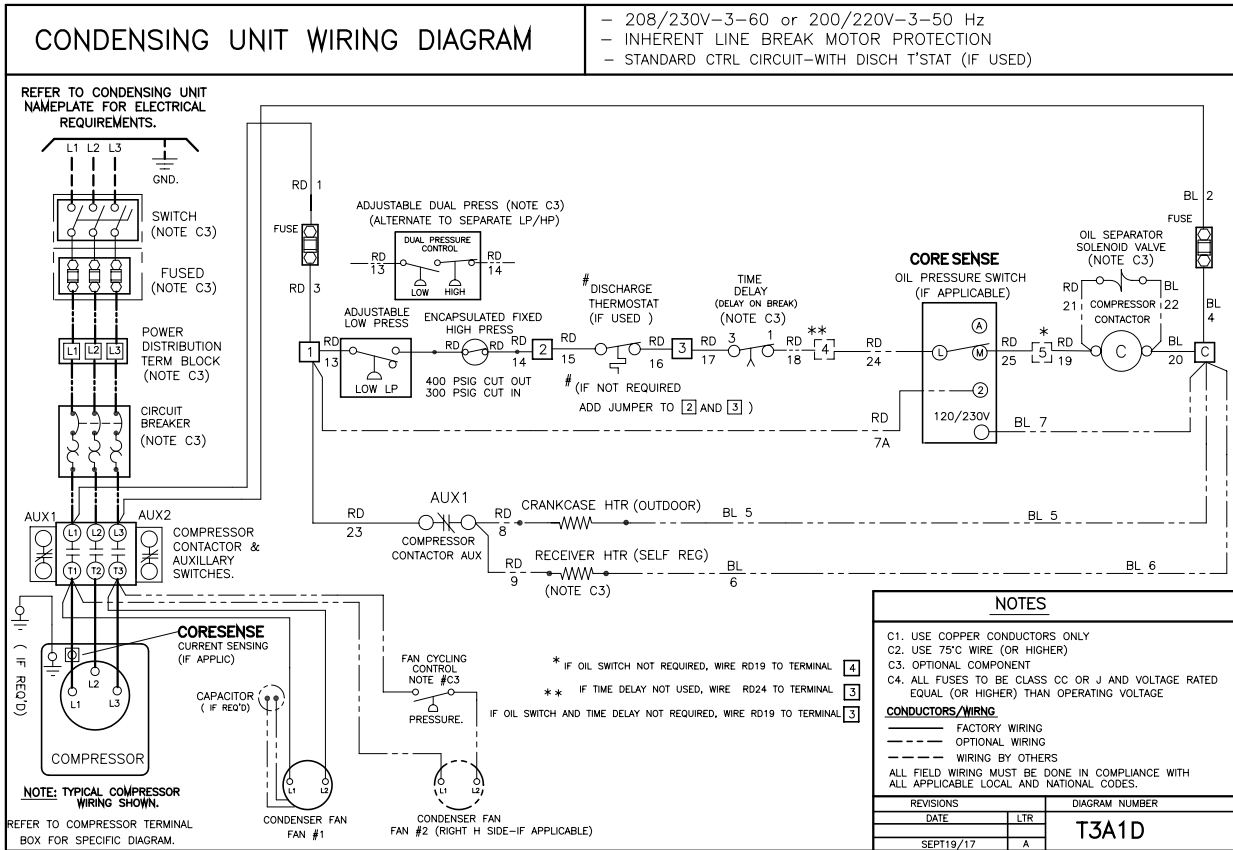

**TYPICAL EVAPORATOR WIRING:** FOR SINGLE LOW PROFILE ELECT 1 PHASE DEFROST EVAPORATOR-SINGLE POINT

FOR USE WITH: 230V SINGLE OR THREE PHASE CONDENSING UNITS WITH DEFROST TIME CLOCK, AND DEFROST HEATER CONTACTOR

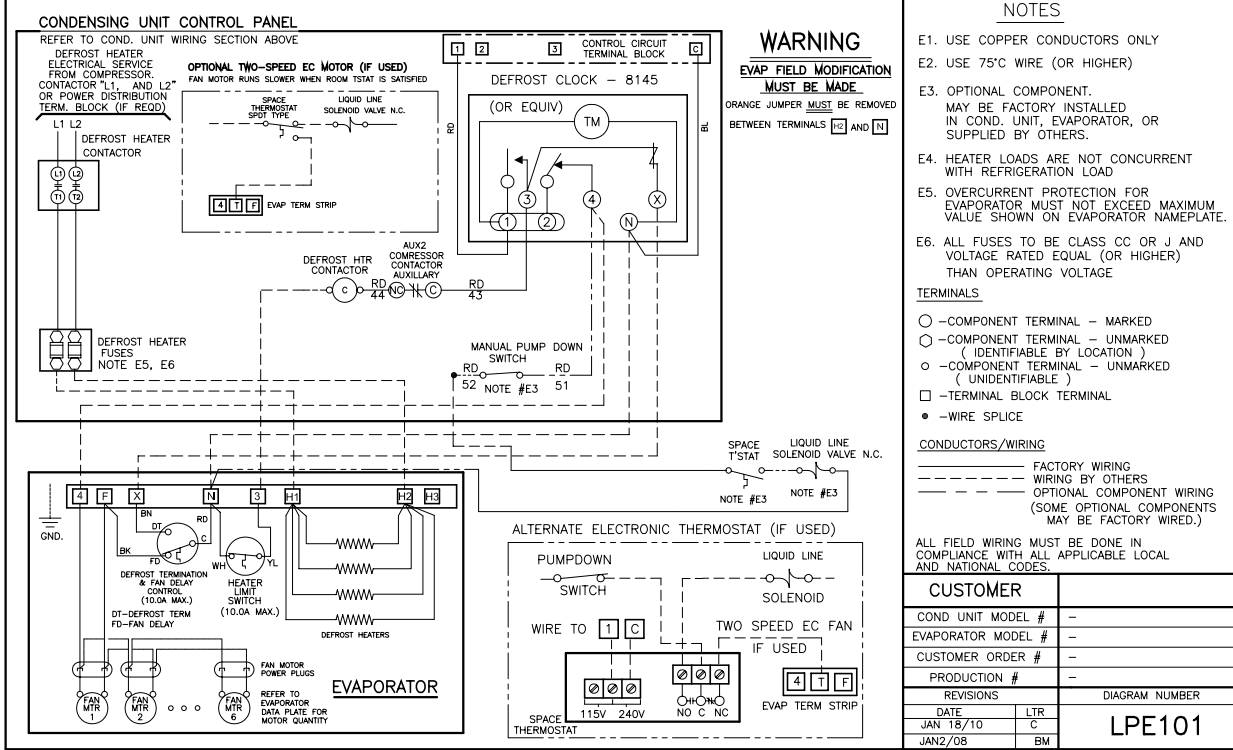

208-230/3/60 Unit with Two (2) 230V Electric Defrost Evaporators

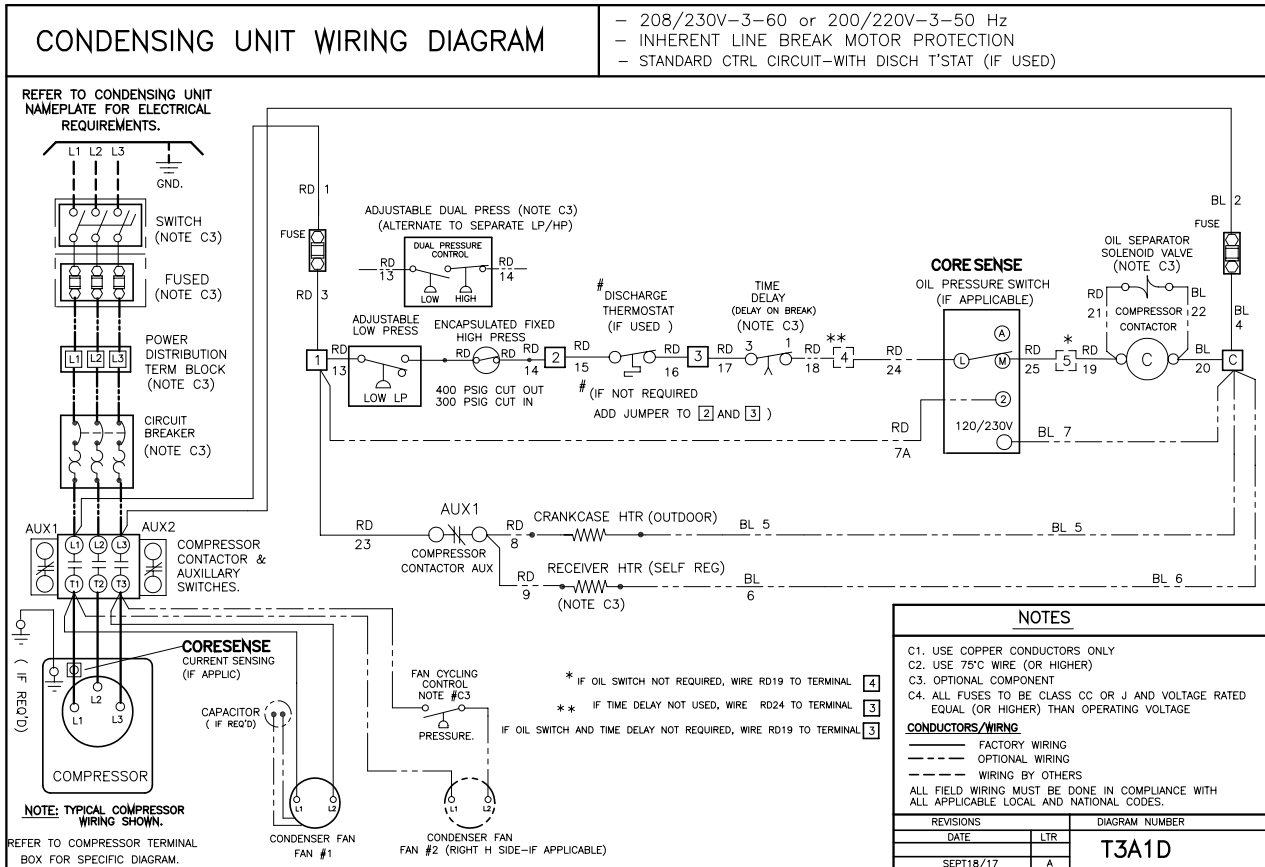

**TYPICAL EVAPORATOR WIRING:** FOR TWO SINGLE LOW PROFILE ELECT DEF 230V 1 PH. EVAPORATORS-SINGLE POINT MAX TOTAL EVAP FAN AMPS-10A

FOR USE WITH: 230V SINGLE OR THREE PHASE CONDENSING UNITS WITH DEFROST TIME CLOCK, AND DEFROST HEATER CONTACTOR

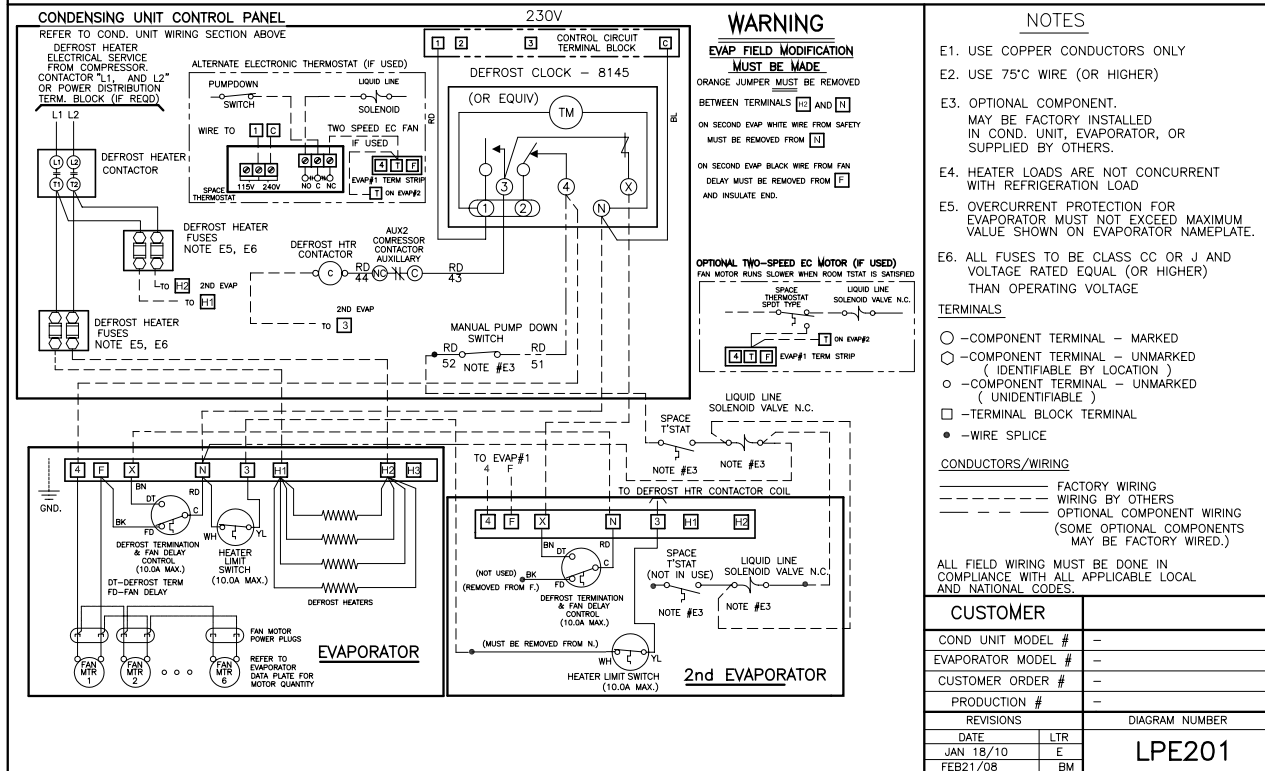



208-230/1/60 Unit with SMARTSPEED™ with 230V Air Defrost Evaporator

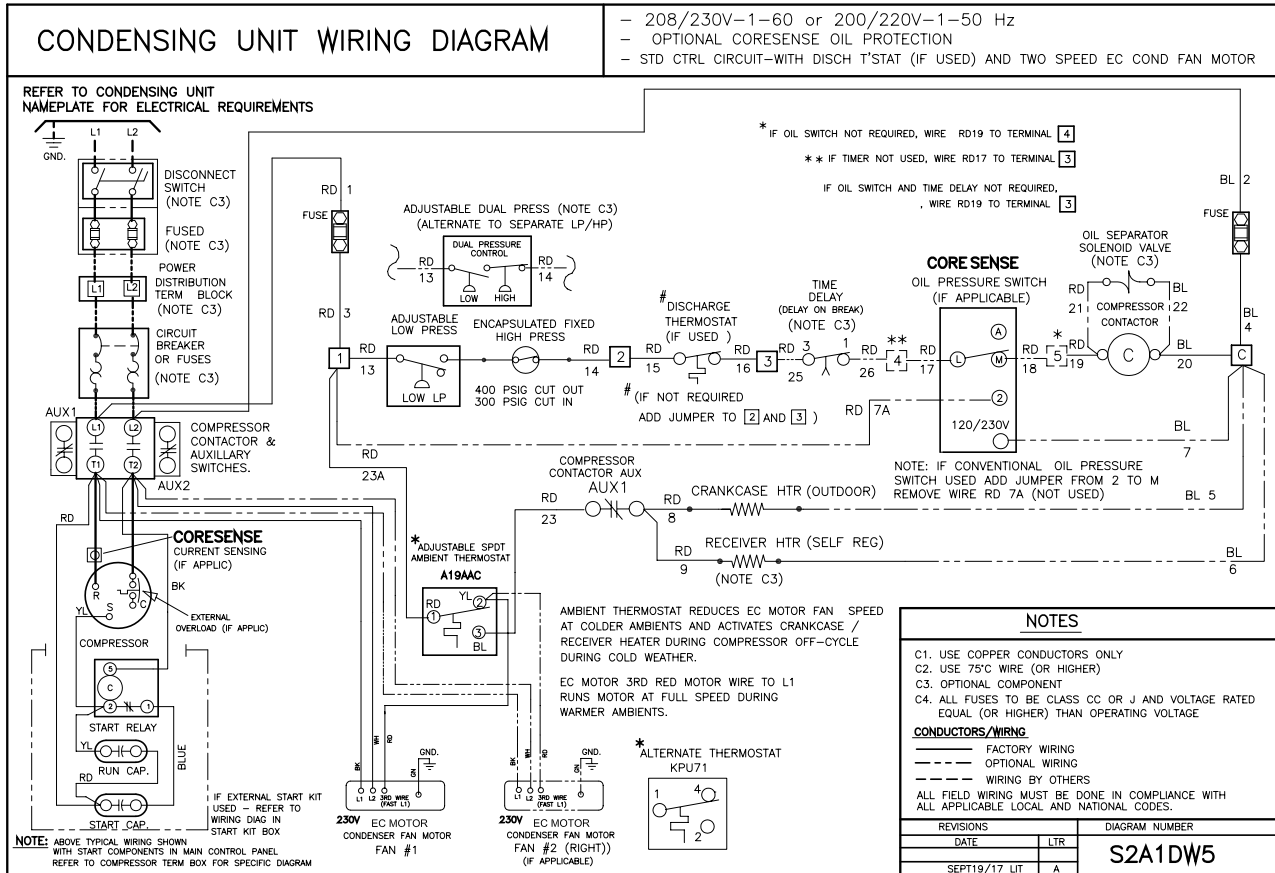

TYPICAL EVAPORATOR WIRING: FOR SINGLE AIR DEFROST EVAPORATOR- SINGLE POINT

FOR USE WITH: 208/230-1-60, 200/220-1-50 OR 208/230-3-60, 200/220-3-50 CONDENSING UNITS WITH OR WITHOUT DEFROST TIME CLOCK AND FOR TOTAL EVAP FAN AMPS NOT EXCEEDING 12A

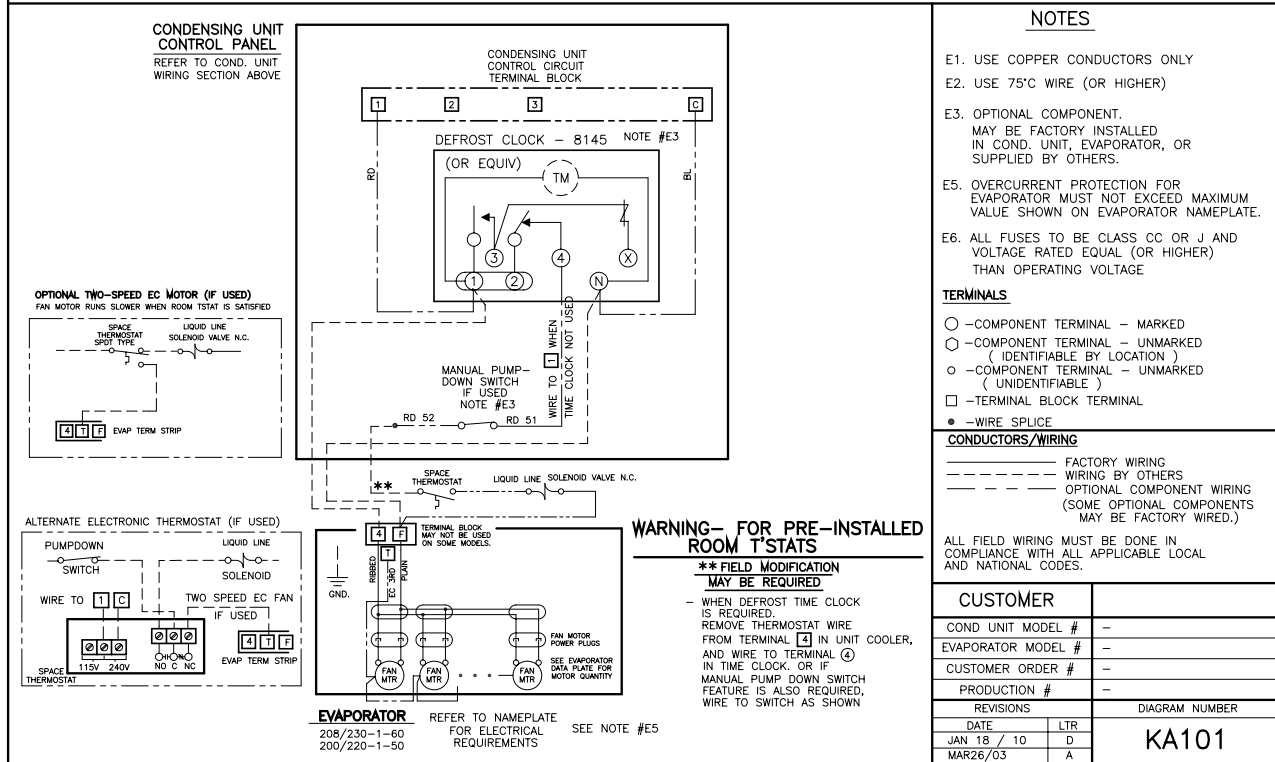

208-230/3/60 Unit with SMARTSPEED™ with 230V Air Defrost Evaporator

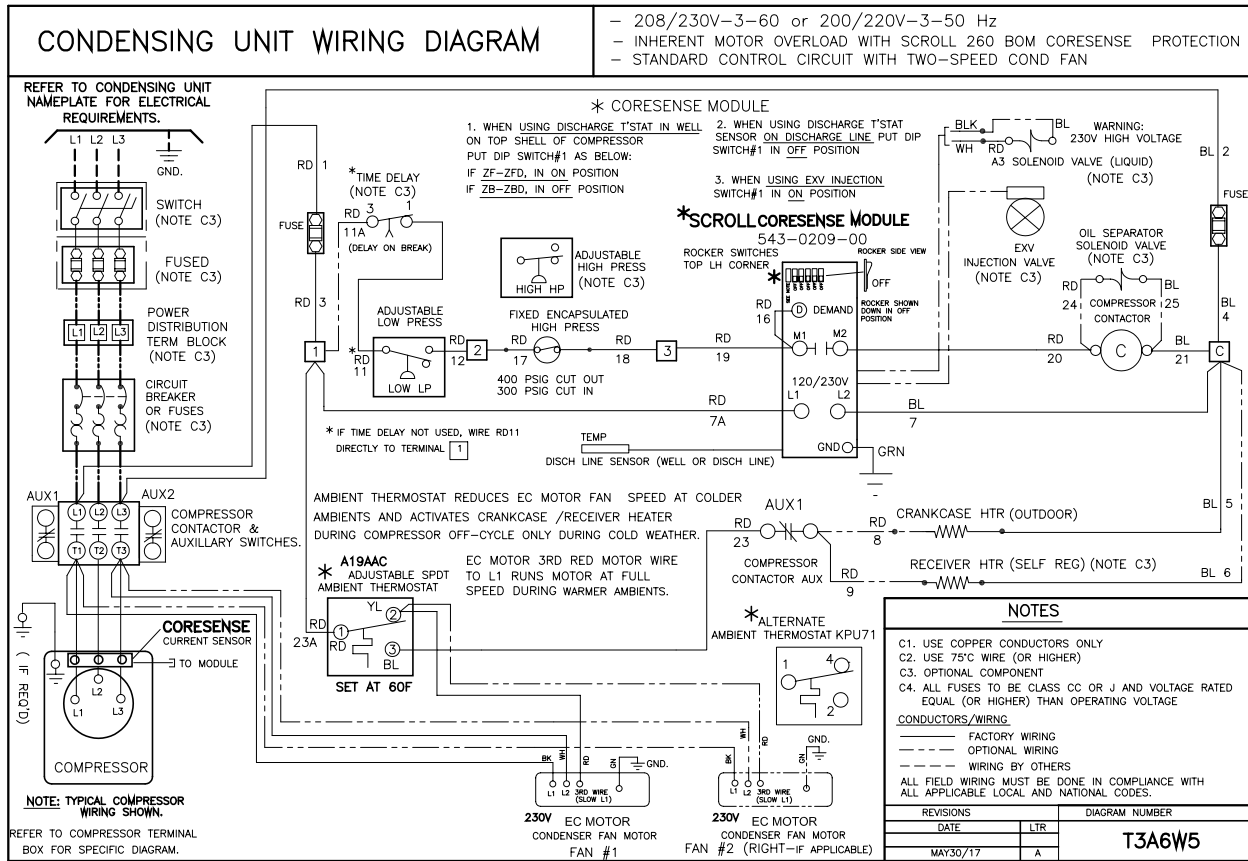

**TYPICAL EVAPORATOR WIRING:** FOR (1) ONE, THREE PHASE MED PROFILE ELECT DEFROST EVAPORATOR - SINGLE POINT WITH SMARTSPEED

FOR USE WITH: THREE PHASE CONDENSING UNITS WITH DEFROST TIME CLOCK, & EVAP FAN AND DEFR. HTR. CONTACTORS.

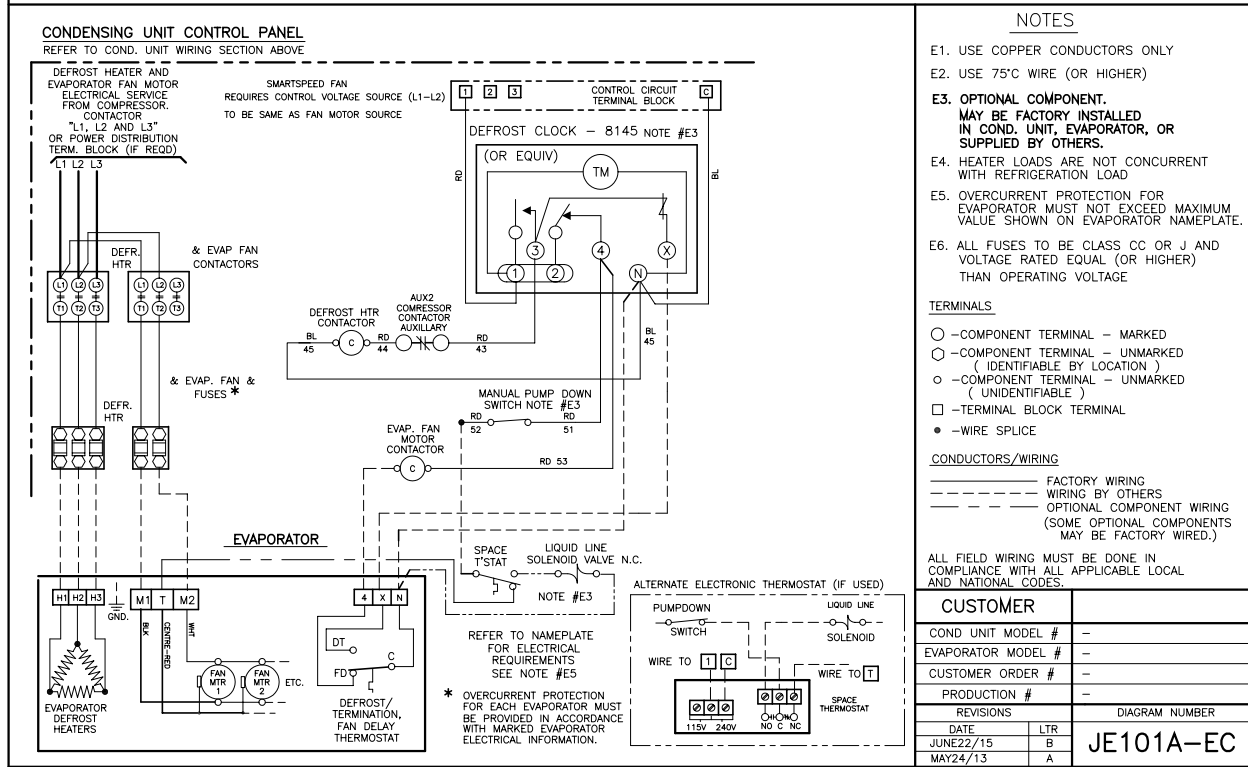





**PROJECT INFORMATION****BEZ - SCROLL CONDENSING UNITS**

System	
Model Number	Date of Start-Up
Serial Number	Service Contractor
Refrigerant	Phone
Electrical Supply	E-mail

  
PRODUCT SUPPORT

web: [www.b-rp.ca/bez](http://www.b-rp.ca/bez)  
email: [smcu@b-rp.ca](mailto:smcu@b-rp.ca)  
call: 1-844-893-3222 x521

  
TROUBLESHOOTING

email: [troubleshooting@b-rp.ca](mailto:troubleshooting@b-rp.ca)  
call: 1-844-893-3222 x529

  
SERVICE PARTS

web: [www.b-rp.ca/parts](http://www.b-rp.ca/parts)  
email: [parts@b-rp.ca](mailto:parts@b-rp.ca)  
call: 1-844-893-3222 x504

  
WARRANTY

web: [www.b-rp.ca/warranty](http://www.b-rp.ca/warranty)  
email: [warranty@b-rp.ca](mailto:warranty@b-rp.ca)  
call: 1-844-893-3222 x507

  
ORDERS

email: [orders@b-rp.ca](mailto:orders@b-rp.ca)  
call: 1-844-893-3222 x501

  
SHIPPING

email: [shipping@b-rp.ca](mailto:shipping@b-rp.ca)  
call: 1-844-893-3222 x503



Bally Refrigeration  
Morehead City, NC • Brantford, ON • Longview, TX  
1-800-242-2559 [ballysales@ballyrefboxes.com](mailto:ballysales@ballyrefboxes.com) [www.ballyrefboxes.com](http://www.ballyrefboxes.com)



DISTRIBUTED BY:

