



BX-Line Condensing Units

PRODUCT DATA & SPECIFICATIONS

Bulletin B40-BX-PDS-5
Part # 1082041

60
Hz

Indoor Water Cooled
Coaxial Hermetic, Scroll
and Semi-Hermetic
Condensing Units

**1/2 to 6 HP -
High, Medium and Low
Temperature Refrigeration**

PRODUCT SUPPORT
 web: b-rp.ca/bx
 email: rcu-wccu@b-rp.ca
 call: 1-844-893-3222 x523

scan:

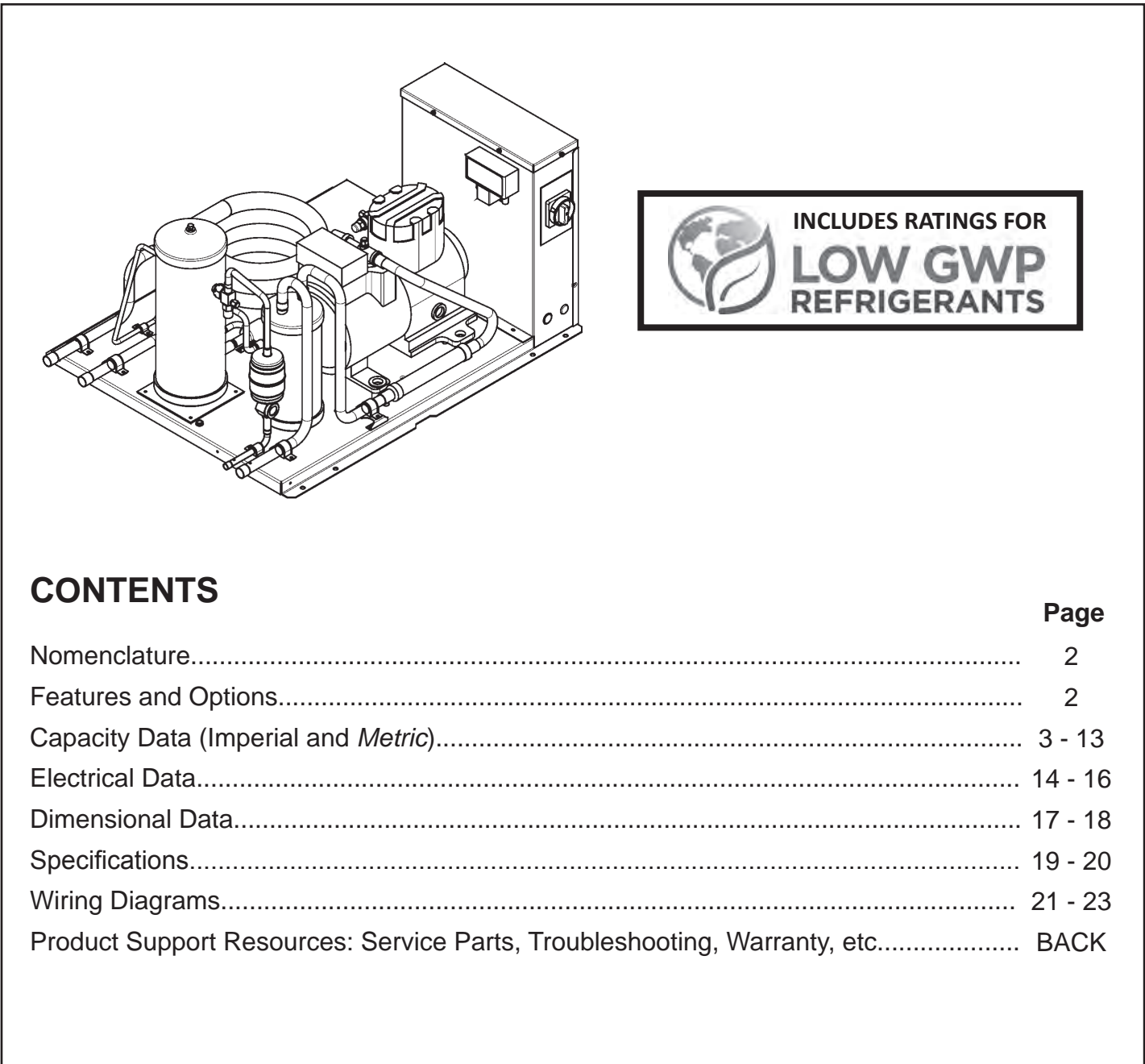

CONTENTS

	Page
Nomenclature.....	2
Features and Options.....	2
Capacity Data (Imperial and <i>Metric</i>).....	3 - 13
Electrical Data.....	14 - 16
Dimensional Data.....	17 - 18
Specifications.....	19 - 20
Wiring Diagrams.....	21 - 23
Product Support Resources: Service Parts, Troubleshooting, Warranty, etc.....	BACK

NOMENCLATURE

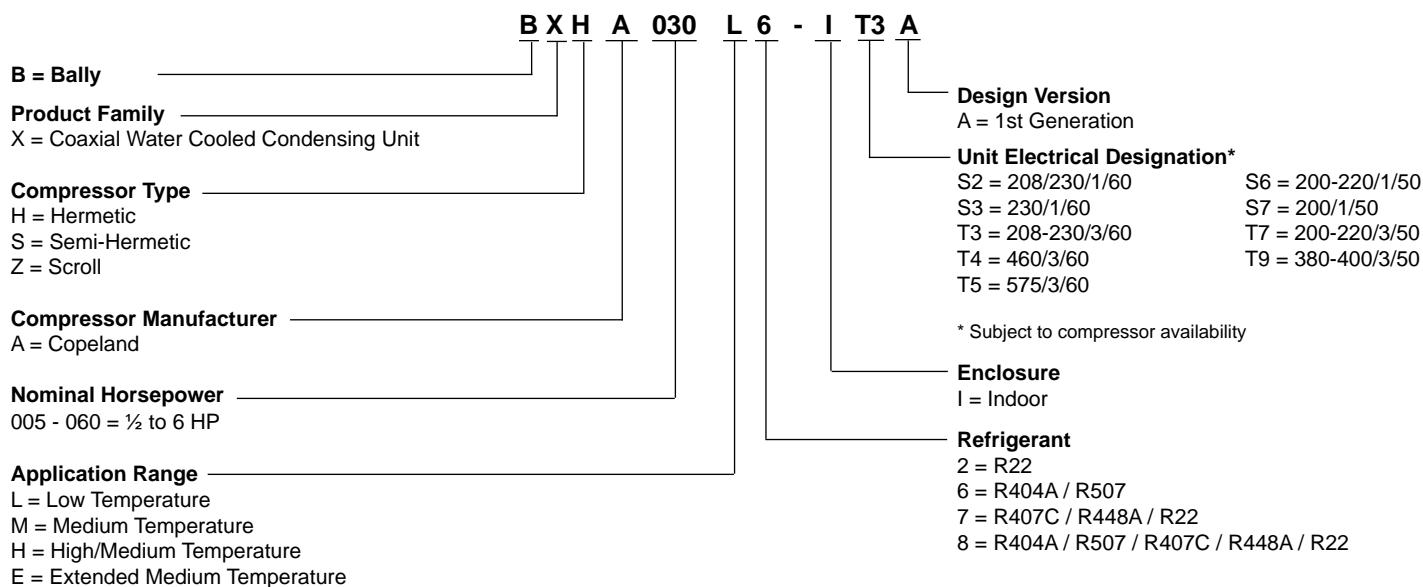

STANDARD FEATURES

- Weatherproof electrical control box with compressor contactor and fused control circuit
- Pre-formed piping
- Base valve on suction line (BXH)
- Suction service valve (BXS, BXZ)
- Copper tubing secured with cushion clamps
- Semi-hermetics spring mounted with vibration absorber (BXS)
- Hermetics/scrolls rubber mounted (BXH, BXZ)
- Co-Axial condenser
- Receiver with fusible plug and liquid shut off valve
- Adjustable dual high / low pressure control with flex hoses
- Each unit subjected to a thorough leak test with Helium leak-detectors
- Units are shipped with Helium holding charge
- Liquid injection (Low temperature scroll only) (BXZ)
- Water reg valve (shipped loose)

AVAILABLE OPTIONS

- Suction accumulator
- Suction accumulator with boil-out coil
- Discharge line check valve
- Oil separator
- Oil separator c/w oil return filter & solenoid valve
- Receiver inlet ball valve
- Over-sized receiver
- Sealed liquid line filter drier & sight glass
- Ball valve – liquid line (shipped loose)
- Insulated suction lines
- Liquid line solenoid valve (with standard 230 volt coil) – shipped loose
- Compressor circuit breaker
- Defrost heater contactor c/w fuse block
- Evaporator fan contactor c/w fuse block
- Disconnect switch
- Disconnect fusing
- Pump down toggle switch
- Lock out control circuit – Liquid solenoid valve with separate HP and LP controls
- Time delay relay for compressor
- Mechanical time clock
- Electronic voltage/phase monitor

CAPACITY DATA - **R407C** HIGH / MEDIUM TEMPERATURE

Capacity Rating Conditions: 85°F (29.4°C) Entering Water, 105°F (40.6°C) Condensing, 0°F (0°C) Subcooling

MODEL BXHA	SATURATED SUCTION TEMPERATURE °F (°C)									
	10 (-12.2)	15 (-9.4)	20 (-6.7)	25 (-3.9)	30 (-1.1)	35 (1.7)	40 (4.4)	45 (7.2)	50 (10.0)	55 (12.8)
BXHA005H7 Compressor: RST45C1E	BTU/H (Watts)	3700 (1080)	4260 (1250)	4880 (1430)	5560 (1630)	6310 (1850)	7130 (2090)	8010 (2350)	8950 (2620)	9950 (2910)
	GPM (L/min)	0.7 (2.7)	0.9 (3.4)	1.1 (4.1)	1.3 (5)	1.6 (6)	1.9 (7.2)	2.3 (8.7)	2.7 (10.4)	3.2 (12.2)
	PSIG (kPa)	0.5 (3.8)	0.7 (5)	0.9 (6.5)	1.3 (8.7)	1.7 (11.5)	2.2 (15.3)	2.9 (20.3)	3.9 (27)	5.0 (34.5)
BXHA008H7 Compressor: RST55C1E	BTU/H (Watts)	4550 (1330)	5210 (1530)	5940 (1740)	6740 (1980)	7630 (2240)	8590 (2520)	9650 (2830)	10800 (3170)	12100 (3510)
	GPM (L/min)	1.0 (4)	1.3 (4.8)	1.5 (5.9)	1.9 (7.1)	2.3 (8.6)	2.7 (10.3)	3.3 (12.4)	3.9 (14.9)	4.6 (17.3)
	PSIG (kPa)	0.9 (6.3)	1.2 (8.3)	1.6 (11)	2.1 (14.7)	2.9 (19.9)	3.9 (26.8)	5.3 (36.4)	7.2 (49.8)	9.4 (65.8)
BXHA010H7 Compressor: RST70C1E	BTU/H (Watts)	6160 (1810)	7010 (2050)	7950 (2330)	8960 (2630)	10100 (2960)	11300 (3310)	12700 (3720)	14200 (4160)	15800 (4600)
	GPM (L/min)	1.5 (5.6)	1.8 (6.8)	2.2 (8.3)	2.6 (10)	3.2 (12.1)	3.8 (14.5)	4.6 (17.3)	5.5 (20.7)	6.5 (24.1)
	PSIG (kPa)	0.4 (3)	0.6 (4.1)	0.8 (5.6)	1.1 (7.6)	1.5 (10.4)	2.1 (14.3)	2.8 (19.6)	3.9 (27.1)	5.0 (34.5)
BXHA015H7 Compressor: CR18K6E	BTU/H (Watts)	7520 (2200)	8860 (2600)	10300 (3020)	11800 (3460)	13400 (3930)	15200 (4450)	17000 (4980)	19000 (5570)	21200 (6160)
	GPM (L/min)	1.5 (5.8)	2.1 (7.9)	2.7 (10.3)	3.5 (13.3)	4.4 (16.7)	5.5 (20.9)	6.8 (25.8)	8.3 (31.5)	10.0 (38)
	PSIG (kPa)	0.5 (3.6)	0.8 (5.6)	1.2 (8.6)	1.9 (12.9)	2.8 (19.1)	4.1 (28)	5.9 (40.8)	8.5 (58.6)	11.5 (82.7)
BXHA020H7 Compressor: CR24K6E	BTU/H (Watts)	9800 (2870)	11500 (3370)	13400 (3930)	15400 (4510)	17500 (5130)	19700 (5770)	22200 (6510)	24800 (7270)	27600 (8030)
	GPM (L/min)	2.0 (7.4)	2.8 (10.5)	3.7 (14.2)	4.9 (18.6)	6.3 (24)	8.0 (30.4)	10.0 (38)	12.4 (47)	15.2 (55.1)
	PSIG (kPa)	0.8 (5.8)	1.3 (9.3)	2.1 (14.4)	3.2 (22)	4.8 (32.9)	7.1 (48.7)	10.3 (71.3)	15.0 (103.6)	20.5 (147.7)
BXHA025H7 Compressor: CR32K6E	BTU/H (Watts)	13000 (3810)	15300 (4480)	17700 (5190)	20300 (5950)	23100 (6770)	26100 (7650)	29300 (8590)	32800 (9610)	36600 (10650)
	GPM (L/min)	1.3 (4.8)	2.3 (8.7)	3.6 (13.7)	5.3 (19.9)	7.3 (27.5)	9.7 (36.7)	12.6 (47.8)	16.2 (61.2)	20.5 (75.1)
	PSIG (kPa)	0.3 (1.9)	0.6 (4)	1.1 (7.5)	1.9 (13)	3.1 (21.5)	5.0 (34.5)	7.9 (54.3)	12.1 (83.5)	17.0 (122.7)
BXHA030H7 Compressor: CR38K6E	BTU/H (Watts)	15400 (4510)	18300 (5360)	21500 (6300)	25100 (7360)	29000 (8500)	33100 (9700)	37500 (10990)	42100 (12340)	47000 (13800)
	GPM (L/min)	2.4 (9.3)	3.6 (13.5)	5.0 (19.1)	6.9 (26.1)	9.2 (34.7)	11.9 (44.9)	15.0 (56.9)	18.6 (70.6)	22.8 (83.1)
	PSIG (kPa)	0.7 (4.6)	1.1 (7.8)	1.9 (13)	3.1 (21.2)	4.9 (33.7)	7.6 (52.1)	11.4 (78.7)	16.8 (115.7)	23.0 (166.8)
BXHA035H7 Compressor: CR42K6E	BTU/H (Watts)	17300 (5070)	20500 (6010)	24200 (7090)	28200 (8260)	32600 (9550)	37400 (10960)	42300 (12400)	47500 (13920)	53000 (15400)
	GPM (L/min)	1.8 (6.8)	3.0 (11.3)	4.6 (17.3)	6.6 (25)	9.1 (34.6)	12.3 (46.5)	15.9 (60.2)	20.1 (76.1)	24.8 (90.1)
	PSIG (kPa)	0.3 (2)	0.5 (3.6)	0.9 (6.1)	1.4 (9.8)	2.2 (15.4)	3.4 (23.7)	5.1 (35.2)	7.4 (51)	10.5 (75.7)
BXHA040H7 Compressor: CR53KQE	BTU/H (Watts)	20700 (6070)	24700 (7240)	28800 (8440)	33300 (9760)	38100 (11170)	43300 (12690)	49000 (14360)	55000 (16120)	61300 (17850)
	GPM (L/min)	4.0 (15)	5.3 (20.2)	6.9 (26.3)	8.9 (33.6)	11.2 (42.3)	13.9 (52.8)	17.3 (65.3)	21.1 (80)	25.5 (93.1)
	PSIG (kPa)	0.8 (5.7)	1.2 (8.5)	1.8 (12.2)	2.5 (17.5)	3.6 (24.7)	5.0 (34.8)	7.1 (49.1)	10.0 (68.7)	13.8 (98.7)
BXHA050H7 Compressor: CRN0-050E	BTU/H (Watts)	28700 (8410)	33100 (9700)	37800 (11080)	42700 (12510)	48100 (14100)	54000 (15830)	61000 (17880)	69000 (20220)	77300 (22650)
	GPM (L/min)	6.6 (25.1)	8.2 (31)	10.0 (37.7)	12.0 (45.3)	14.4 (54.3)	17.1 (64.8)	20.7 (78.4)	25.2 (95.2)	30.0 (111.8)
	PSIG (kPa)	0.8 (5.9)	1.2 (8.3)	1.7 (11.6)	2.3 (15.9)	3.2 (21.9)	4.4 (30.1)	6.2 (42.6)	8.9 (61.1)	12.5 (89.6)

NOTE: The capacities shown above are rated at dew point. The dew point is a saturation point and is the condition (pressure and temperature) at which a gas begins to condense. Since R407C has significant glide, the saturated gas and saturated liquid temperatures are not the same. It is important that all components of a system are selected correctly

CAPACITY DATA - R404A R507

EXTENDED MEDIUM TEMPERATURE

Capacity Rating Conditions: 85°F (29.4°C) Entering Water, 105°F (40.6°C) Condensing, 0°F (0°C) Subcooling

MODEL BXHA	SATURATED SUCTION TEMPERATURE °F (°C)										
		-25 (-31.7)	-20 (-28.9)	-10 (-23.3)	0 (-17.8)	10 (-12.2)	20 (-6.7)	25 (-3.9)	30 (-1.1)		
BXHA006E6 Compressor: RST45C1E	BTU/H (Watts)	1240 (360)	1620 (470)	2380 (700)	3200 (940)	4090 (1200)	5110 (1500)	5680 (1660)	6290 (1840)		
	GPM (L/min)	0.2 (0.7)	0.3 (1)	0.4 (1.6)	0.6 (2.3)	0.9 (3.3)	1.2 (4.6)	1.4 (5.4)	1.7 (6.3)		
	PSIG (kPa)	0.1 (0.5)	0.1 (0.7)	0.2 (1.3)	0.3 (2.2)	0.5 (3.7)	0.9 (6)	1.1 (7.6)	1.4 (9.7)		
BXHA008E6 Compressor: RST64C1E	BTU/H (Watts)	2070 (610)	2360 (690)	3090 (910)	4030 (1180)	5170 (1520)	6490 (1900)	7220 (2120)	7990 (2340)		
	GPM (L/min)	0.2 (0.9)	0.3 (1.1)	0.4 (1.5)	0.6 (2.2)	0.8 (3.1)	1.1 (4.3)	1.3 (5.1)	1.6 (5.9)		
	PSIG (kPa)	0.1 (1)	0.2 (1.2)	0.3 (1.8)	0.4 (2.8)	0.6 (4.4)	1.0 (7.1)	1.3 (8.9)	1.6 (11.2)		
BXHA009E6 Compressor: RST64C1E	BTU/H (Watts)	2380 (700)	2860 (840)	3940 (1150)	5190 (1520)	6610 (1940)	8190 (2400)	9050 (2650)	9950 (2920)		
	GPM (L/min)	0.4 (1.4)	0.4 (1.7)	0.7 (2.5)	1.0 (3.6)	1.4 (5.1)	1.9 (7)	2.2 (8.2)	2.5 (9.5)		
	PSIG (kPa)	0.2 (1.6)	0.3 (2)	0.5 (3.4)	0.8 (5.5)	1.3 (9)	2.1 (14.6)	2.7 (18.7)	3.4 (23.6)		
BXHA010E6 Compressor: RST70C1E	BTU/H (Watts)	2390 (700)	2880 (840)	4010 (1180)	5330 (1560)	6840 (2000)	8550 (2510)	9480 (2780)	10500 (3080)		
	GPM (L/min)	0.3 (1.2)	0.4 (1.5)	0.6 (2.3)	0.9 (3.4)	1.3 (4.9)	1.8 (6.8)	2.1 (7.9)	2.4 (9.1)		
	PSIG (kPa)	0.2 (1.4)	0.3 (1.8)	0.4 (3.1)	0.7 (5.2)	1.2 (8.5)	2.0 (13.8)	2.5 (17.5)	3.2 (21.9)		
BXHA015E6 Compressor: CS10K6E	BTU/H (Watts)	1970 (580)	2710 (790)	4580 (1340)	6930 (2030)	9710 (2850)	12900 (3780)	14600 (4280)	16300 (4780)		
	GPM (L/min)	0.0 (0.1)	0.1 (0.4)	0.3 (1.3)	0.8 (3)	1.5 (5.6)	2.5 (9.4)	3.1 (11.7)	3.8 (14.3)		
	PSIG (kPa)	0.1 (0.7)	0.1 (0.7)	0.1 (0.5)	0.2 (1.4)	0.5 (3.4)	1.1 (7.4)	1.5 (10.5)	2.1 (14.7)		
BXHA020E6 Compressor: CS12K6E	BTU/H (Watts)	2610 (760)	3500 (1030)	5670 (1660)	8340 (2440)	11500 (3370)	15100 (4430)	17100 (5010)	19200 (5630)		
	GPM (L/min)	0.1 (0.4)	0.2 (0.7)	0.6 (2.1)	1.2 (4.4)	2.1 (8.1)	3.5 (13.2)	4.3 (16.4)	5.3 (20.1)		
	PSIG (kPa)	0.1 (0.7)	0.1 (0.7)	0.1 (0.9)	0.3 (2.4)	0.8 (5.8)	1.9 (12.8)	2.7 (18.5)	3.8 (26.2)		
BXHA025E6 Compressor: CS14K6E	BTU/H (Watts)	3780 (1110)	4750 (1390)	7160 (2100)	10100 (2960)	13600 (3990)	17500 (5130)	19600 (5740)	21800 (6390)		
	GPM (L/min)	0.2 (0.8)	0.3 (1.2)	0.7 (2.6)	1.3 (5)	2.3 (8.7)	3.7 (14.1)	4.6 (17.6)	5.7 (21.4)		
	PSIG (kPa)	0.1 (0.4)	0.1 (0.7)	0.2 (1.6)	0.5 (3.4)	1.0 (7.2)	2.1 (14.4)	2.9 (20)	4.0 (27.5)		
BXHA030E6 Compressor: CS18K6E	BTU/H (Watts)	4530 (1330)	5590 (1640)	8630 (2530)	12700 (3720)	17500 (5130)	22900 (6710)	25700 (7530)	28500 (8350)		
	GPM (L/min)	0.1 (0.3)	0.1 (0.5)	0.4 (1.4)	0.9 (3.4)	1.9 (7.1)	3.5 (13.3)	4.6 (17.4)	5.8 (22.1)		
	PSIG (kPa)	0.1 (0.7)	0.1 (0.7)	0.1 (0.5)	0.2 (1.2)	0.4 (3.1)	1.0 (7.2)	1.5 (10.6)	2.2 (15.3)		
BXHA035E6 Compressor: CS20K6E	BTU/H (Watts)	4580 (1340)	6420 (1880)	10100 (2960)	14200 (4160)	19200 (5630)	25600 (7500)	29500 (8650)	34000 (9960)		
	GPM (L/min)	0.1 (0.4)	0.2 (0.8)	0.6 (2.2)	1.2 (4.7)	2.5 (9.5)	4.9 (18.6)	6.9 (26.2)	9.7 (36.8)		
	PSIG (kPa)	0.1 (0.7)	0.1 (0.7)	0.1 (0.8)	0.3 (1.8)	0.6 (4.5)	1.7 (11.8)	2.9 (19.9)	5.0 (34.8)		
BXHA040E6 Compressor: CS27K6E	BTU/H (Watts)	7530 (2210)	9410 (2760)	13800 (4040)	19200 (5630)	25800 (7560)	33800 (9910)	38400 (11250)	43300 (12690)		
	GPM (L/min)	0.8 (2.9)	1.1 (4.1)	2.0 (7.5)	3.4 (12.8)	5.4 (20.5)	8.4 (31.9)	10.4 (39.2)	12.6 (47.8)		
	PSIG (kPa)	0.1 (0.8)	0.2 (1.2)	0.4 (2.7)	0.8 (5.7)	1.7 (12)	3.6 (24.8)	5.1 (35.5)	7.3 (50.3)		
BXHA050E6 Compressor: CS33K6E	BTU/H (Watts)	9590 (2810)	10800 (3170)	15300 (4480)	21900 (6420)	29800 (8730)	38300 (11220)	42600 (12480)	46800 (13720)		
	GPM (L/min)	0.7 (2.5)	0.8 (3.1)	1.5 (5.7)	2.8 (10.6)	4.8 (18)	7.3 (27.6)	8.7 (33)	10.1 (38.3)		
	PSIG (kPa)	0.1 (0.7)	0.1 (0.9)	0.3 (1.8)	0.5 (3.7)	1.1 (7.3)	1.9 (13.1)	2.5 (17)	3.1 (21.2)		

CAPACITY DATA - R404A R507

LOW TEMPERATURE

Capacity Rating Conditions: 85°F (29.4°C) Entering Water, 105°F (40.6°C) Condensing, 0°F (0°C) Subcooling

MODEL BXHA	SATURATED SUCTION TEMPERATURE °F (°C)									
		-30 (-34.4)	-20 (-28.9)	-10 (-23.3)	-5 (-20.6)	0 (-17.8)	5 (-15)	10 (-12.2)		
BXHA006L6 Compressor: RFT22C1E	BTU/H (Watts)	1310 (380)	1890 (550)	2580 (760)	2960 (870)	3380 (990)	3830 (1120)	4300 (1260)		
	GPM (L/min)	0.2 (0.9)	0.4 (1.6)	0.7 (2.7)	0.9 (3.3)	1.1 (4.1)	1.3 (5.1)	1.6 (6.1)		
	PSIG (kPa)	0.1 (0.5)	0.1 (1)	0.3 (2)	0.4 (2.8)	0.6 (3.8)	0.8 (5.2)	1.0 (7.1)		
BXHA008L6 Compressor: RFT26C1E	BTU/H (Watts)	1670 (490)	2340 (690)	3140 (920)	3600 (1060)	4100 (1200)	4610 (1350)	5180 (1520)		
	GPM (L/min)	0.5 (1.9)	0.8 (3)	1.2 (4.6)	1.5 (5.6)	1.8 (6.8)	2.2 (8.2)	2.6 (9.8)		
	PSIG (kPa)	0.2 (1.2)	0.3 (2.3)	0.7 (4.5)	0.9 (6.2)	1.2 (8.5)	1.7 (11.6)	2.3 (15.6)		
BXHA010L6 Compressor: CF04K6E	BTU/H (Watts)	2080 (610)	3570 (1050)	5310 (1560)	6370 (1870)	7590 (2220)	9020 (2640)	10700 (3140)		
	GPM (L/min)	0.4 (1.7)	0.9 (3.5)	1.7 (6.3)	2.2 (8.2)	2.8 (10.7)	3.7 (14)	4.8 (18.2)		
	PSIG (kPa)	0.2 (1.5)	0.6 (3.9)	1.4 (9.5)	2.2 (14.8)	3.4 (23.2)	5.3 (36.7)	8.5 (58.5)		
BXHA020L6 Compressor: CF06K6E	BTU/H (Watts)	3660 (1070)	5720 (1680)	8330 (2440)	9800 (2870)	11400 (3340)	13100 (3840)	14900 (4370)		
	GPM (L/min)	0.7 (2.5)	1.3 (4.8)	2.3 (8.6)	2.9 (11.2)	3.7 (14.1)	4.6 (17.6)	5.7 (21.4)		
	PSIG (kPa)	0.5 (3.4)	1.2 (8.3)	2.9 (20.1)	4.4 (30.6)	6.6 (45.4)	9.6 (66.2)	13.6 (93.9)		
BXHA025L6 Compressor: CF09K6E	BTU/H (Watts)	5820 (1710)	8810 (2580)	12400 (3630)	14500 (4250)	16700 (4890)	19100 (5600)	21600 (6330)		
	GPM (L/min)	0.8 (3)	1.7 (6.5)	3.2 (12.3)	4.3 (16.2)	5.5 (20.8)	6.9 (26.2)	8.6 (32.6)		
	PSIG (kPa)	0.2 (1.4)	0.6 (4.2)	1.7 (11.4)	2.6 (18)	4.0 (27.9)	6.1 (42.2)	9.1 (62.5)		
BXHA030L6 Compressor: CF12K6E	BTU/H (Watts)	7850 (2300)	11700 (3430)	16000 (4690)	18400 (5390)	21100 (6180)	24100 (7060)	27300 (8000)		
	GPM (L/min)	1.1 (4.3)	2.4 (9.1)	4.4 (16.8)	5.8 (22.1)	7.6 (28.7)	9.8 (37)	12.5 (47.4)		
	PSIG (kPa)	0.4 (2.8)	1.1 (7.6)	2.7 (18.7)	4.2 (28.9)	6.4 (44.4)	9.9 (68.2)	15.2 (104.9)		

CAPACITY DATA - R22 HIGH / MEDIUM TEMPERATURE

Capacity Rating Conditions: 85°F (29.4°C) Entering Water, 105°F (40.6°C) Condensing, 0°F (0°C) Subcooling

MODEL BXHA	SATURATED SUCTION TEMPERATURE °F (°C)									
		10 (-12.2)	15 (-9.4)	20 (-6.7)	25 (-3.9)	30 (-1.1)	35 (1.7)	40 (4.4)	45 (7.2)	
BXHA005H7 Compressor: RST45C1E	BTU/H (Watts)	4140 (1210)	4680 (1370)	5280 (1550)	5960 (1750)	6720 (1970)	7590 (2220)	8590 (2520)	9720 (2850)	
	GPM (L/min)	0.6 (2.1)	0.7 (2.6)	0.8 (3)	1.0 (3.6)	1.1 (4.3)	1.4 (5.2)	1.7 (6.3)	2.0 (7.6)	
	PSIG (kPa)	0.4 (2.8)	0.5 (3.5)	0.6 (4.3)	0.8 (5.5)	1.0 (7.1)	1.3 (9.2)	1.8 (12.2)	2.4 (16.5)	
BXHA008H7 Compressor: RST55C1E	BTU/H (Watts)	5820 (1710)	6630 (1940)	7530 (2210)	8500 (2490)	9570 (2800)	10700 (3140)	12000 (3520)	13400 (3930)	
	GPM (L/min)	1.1 (4.3)	1.3 (5.1)	1.6 (6.1)	1.9 (7.2)	2.3 (8.6)	2.7 (10.1)	3.2 (12)	3.7 (14.1)	
	PSIG (kPa)	1.0 (6.9)	1.3 (9)	1.7 (11.6)	2.2 (15.1)	2.9 (19.8)	3.8 (26.1)	5.0 (34.4)	6.6 (45.5)	
BXHA010H7 Compressor: RST70C1E	BTU/H (Watts)	6200 (1820)	7310 (2140)	8480 (2490)	9740 (2850)	11100 (3250)	12500 (3660)	14100 (4130)	15800 (4630)	
	GPM (L/min)	0.9 (3.3)	1.1 (4.3)	1.4 (5.5)	1.8 (6.8)	2.2 (8.4)	2.7 (10.2)	3.3 (12.3)	3.9 (14.8)	
	PSIG (kPa)	0.2 (1.4)	0.3 (2)	0.4 (2.9)	0.6 (4)	0.8 (5.6)	1.1 (7.8)	1.6 (10.8)	2.2 (15)	
BXHA015H7 Compressor: CR18K6E	BTU/H (Watts)	7310 (2140)	9140 (2680)	11000 (3220)	13000 (3810)	15000 (4400)	17200 (5040)	19500 (5710)	22000 (6450)	
	GPM (L/min)	0.7 (2.8)	1.1 (4.3)	1.6 (6.2)	2.2 (8.5)	3.0 (11.2)	3.8 (14.3)	4.8 (18)	5.9 (22.4)	
	PSIG (kPa)	0.2 (1.3)	0.3 (2.3)	0.6 (3.9)	0.9 (6.3)	1.4 (9.7)	2.1 (14.7)	3.1 (21.7)	4.6 (31.7)	
BXHA020H7 Compressor: CR24K6E	BTU/H (Watts)	11000 (3220)	12900 (3780)	14900 (4370)	17100 (5010)	19500 (5710)	22100 (6480)	24900 (7300)	27800 (8150)	
	GPM (L/min)	1.3 (5)	1.8 (6.8)	2.4 (9)	3.1 (11.8)	4.0 (15.3)	5.2 (19.5)	6.5 (24.7)	8.2 (31)	
	PSIG (kPa)	0.5 (3.5)	0.7 (5.1)	1.1 (7.5)	1.6 (11)	2.3 (16.2)	3.4 (23.7)	5.0 (34.6)	7.3 (50.4)	
BXHA025H7 Compressor: CR32K6E	BTU/H (Watts)	15300 (4480)	17700 (5190)	20300 (5950)	23100 (6770)	26000 (7620)	29200 (8560)	32600 (9550)	36300 (10640)	
	GPM (L/min)	2.8 (10.6)	3.7 (14.1)	4.9 (18.4)	6.2 (23.6)	7.9 (30)	10.0 (37.7)	12.4 (47.1)	15.5 (58.5)	
	PSIG (kPa)	0.8 (5.2)	1.1 (7.8)	1.7 (11.6)	2.5 (17)	3.6 (24.8)	5.2 (36.1)	7.7 (52.8)	11.2 (77.2)	
BXHA030H7 Compressor: CR38K6E	BTU/H (Watts)	17500 (5130)	20400 (5980)	23500 (6890)	26900 (7880)	30400 (8910)	34200 (10020)	38200 (11200)	42400 (12430)	
	GPM (L/min)	1.5 (5.8)	2.2 (8.4)	3.1 (11.6)	4.1 (15.4)	5.3 (19.9)	6.7 (25.3)	8.3 (31.6)	10.3 (38.9)	
	PSIG (kPa)	0.4 (2.5)	0.6 (4)	0.9 (6.2)	1.4 (9.4)	2.0 (13.9)	2.9 (20.1)	4.2 (28.8)	5.9 (40.8)	
BXHA035H7 Compressor: CR42K6E	BTU/H (Watts)	19600 (5740)	22800 (6680)	26200 (7680)	29900 (8760)	33800 (9910)	38100 (11170)	42700 (12510)	47600 (13950)	
	GPM (L/min)	0.9 (3.6)	1.6 (6.1)	2.5 (9.3)	3.5 (13.3)	4.8 (18.2)	6.4 (24.3)	8.3 (31.5)	10.6 (40.1)	
	PSIG (kPa)	0.1 (1)	0.3 (1.8)	0.4 (2.9)	0.6 (4.4)	0.9 (6.5)	1.4 (9.5)	2.0 (13.5)	2.8 (19.1)	
BXHA040H7 Compressor: CR53KQE	BTU/H (Watts)	25800 (7560)	29700 (8700)	34000 (9960)	38600 (11310)	43700 (12810)	49200 (14420)	55400 (16240)	62300 (18260)	
	GPM (L/min)	3.3 (12.3)	4.2 (15.8)	5.3 (20)	6.6 (24.9)	8.1 (30.8)	10.0 (38)	12.4 (46.8)	15.2 (57.6)	
	PSIG (kPa)	0.7 (4.5)	0.9 (6.2)	1.2 (8.4)	1.6 (11.3)	2.2 (15.4)	3.0 (20.9)	4.2 (28.8)	5.8 (40)	
BXHA050H7 Compressor: CRNQ-050E	BTU/H (Watts)	30700 (9000)	35400 (10370)	40500 (11870)	45800 (13420)	51600 (15120)	57800 (16940)	64600 (18930)	71900 (21070)	
	GPM (L/min)	4.5 (17.1)	5.6 (21)	6.7 (25.5)	8.1 (30.6)	9.6 (36.4)	11.4 (43.1)	13.4 (50.8)	15.8 (59.8)	
	PSIG (kPa)	0.5 (3.2)	0.6 (4.4)	0.9 (6)	1.2 (8.1)	1.6 (10.9)	2.1 (14.6)	2.8 (19.5)	3.8 (26)	

CAPACITY DATA - R404A R507
MEDIUM TEMPERATURE

Capacity Rating Conditions: 85°F (29.4°C) Entering Water, 105°F (40.6°C) Condensing, 0°F (0°C) Subcooling

MODEL BXSA	SATURATED SUCTION TEMPERATURE °F (°C)									
	-5 (-20.6)	0 (-17.8)	5 (-15)	10 (-12.2)	15 (-9.4)	20 (-6.7)	25 (-3.9)			
BXSA005M6 Compressor: HAJA-005E	BTU/H (Watts)	2350 (690)	2710 (790)	3080 (900)	3470 (1020)	3900 (1140)	4400 (1290)	4970 (1460)		
	GPM (L/min)	0.6 (2.1)	0.6 (2.2)	0.6 (2.4)	0.7 (2.6)	0.8 (2.9)	0.9 (3.3)	1.0 (3.9)		
	PSIG (kPa)	0.3 (1.8)	0.3 (1.9)	0.3 (2.2)	0.4 (2.5)	0.4 (3)	0.5 (3.6)	0.7 (4.5)		
BXSA010M6 Compressor: KARB-010E	BTU/H (Watts)	4870 (1430)	5540 (1620)	6320 (1850)	7170 (2100)	8070 (2370)	8980 (2630)	9870 (2890)		
	GPM (L/min)	1.2 (4.5)	1.3 (4.8)	1.4 (5.3)	1.6 (5.9)	1.8 (6.8)	2.1 (7.8)	2.3 (8.8)		
	PSIG (kPa)	1.1 (7.3)	1.2 (8)	1.3 (9.3)	1.6 (11.1)	2.0 (13.8)	2.5 (17.1)	3.0 (21)		
BXSA020M6 Compressor: KAKA-020E	BTU/H (Watts)	7920 (2320)	8930 (2620)	10200 (2990)	11600 (3400)	13100 (3840)	14800 (4340)	16400 (4810)		
	GPM (L/min)	1.3 (4.8)	1.5 (5.6)	1.8 (6.8)	2.2 (8.3)	2.7 (10.2)	3.3 (12.5)	3.9 (14.9)		
	PSIG (kPa)	0.5 (3.6)	0.6 (4.2)	0.7 (5.1)	0.9 (6.5)	1.3 (8.7)	1.7 (11.7)	2.3 (15.5)		
BXSA021M6 Compressor: ERCA-021E	BTU/H (Watts)	9610 (2820)	11200 (3280)	12800 (3750)	14600 (4280)	16400 (4810)	18500 (5420)	20800 (6100)		
	GPM (L/min)	1.6 (5.9)	1.9 (7)	2.3 (8.6)	2.8 (10.6)	3.5 (13.1)	4.3 (16.4)	5.4 (20.4)		
	PSIG (kPa)	0.6 (4.1)	0.8 (5.3)	1.0 (6.9)	1.4 (9.4)	1.9 (12.9)	2.6 (18)	3.7 (25.4)		
BXSA030M6 Compressor: ERFA-031E	BTU/H (Watts)	14300 (4190)	16400 (4810)	18600 (5450)	21100 (6180)	23800 (6980)	26700 (7820)	30000 (8790)		
	GPM (L/min)	3.1 (11.7)	3.1 (11.7)	3.3 (12.5)	3.8 (14.3)	4.6 (17.5)	5.8 (22.1)	7.6 (28.7)		
	PSIG (kPa)	0.9 (6.2)	0.9 (6.1)	1.0 (7)	1.3 (9.1)	1.9 (13.1)	2.9 (19.8)	4.5 (30.8)		
BXSA035M6 Compressor: 3RAA-031E	BTU/H (Watts)	16100 (4720)	18800 (5510)	21800 (6390)	25000 (7330)	28600 (8380)	32500 (9520)	36700 (10760)		
	GPM (L/min)	7.8 (29.5)	7.1 (26.8)	6.7 (25.2)	6.6 (24.9)	6.9 (26.3)	7.8 (29.5)	9.3 (35.2)		
	PSIG (kPa)	3.2 (21.8)	2.7 (18.8)	2.5 (17.2)	2.5 (16.9)	2.6 (18.3)	3.2 (21.9)	4.2 (29.2)		
BXSA040M6 Compressor: NRB2-040E	BTU/H (Watts)	18200 (5330)	21400 (6270)	24700 (7240)	28400 (8320)	32300 (9470)	36700 (10760)	41500 (12160)		
	GPM (L/min)	4.0 (15)	4.3 (16.3)	4.8 (18.2)	5.6 (21.1)	6.6 (25)	8.0 (30.1)	9.7 (36.8)		
	PSIG (kPa)	0.7 (5)	0.8 (5.8)	1.0 (7)	1.3 (9)	1.8 (12.1)	2.4 (16.7)	3.4 (23.6)		

CAPACITY DATA - R404A R507
LOW TEMPERATURE

Capacity Rating Conditions: 85°F (29.4°C) Entering Water, 105°F (40.6°C) Condensing, 0°F (0°C) Subcooling

MODEL BXSA	SATURATED SUCTION TEMPERATURE °F (°C)									
	-40 (-40)	-30 (-34.4)	-20 (-28.9)	-15 (-26.1)	-10 (-23.3)	0 (-17.8)				
BXSA005L6 Compressor: KANB-005E	BTU/H (Watts)	730 (210)	1240 (360)	1910 (560)	2310 (680)	2750 (810)	3740 (1100)			
	GPM (L/min)	0.9 (3.4)	0.7 (2.8)	0.7 (2.6)	0.7 (2.8)	0.8 (3.1)	1.2 (4.6)			
	PSIG (kPa)	0.4 (3.1)	0.4 (2.6)	0.4 (2.5)	0.4 (2.6)	0.4 (2.8)	0.6 (4.4)			
BXSA008L6 Compressor: KAMB-007E	BTU/H (Watts)	1750 (510)	2360 (690)	3320 (970)	3910 (1150)	4550 (1330)	5940 (1740)			
	GPM (L/min)	0.5 (2)	0.6 (2.3)	0.8 (3)	0.9 (3.5)	1.1 (4.3)	1.7 (6.4)			
	PSIG (kPa)	0.2 (1.7)	0.3 (2)	0.4 (3)	0.6 (4)	0.8 (5.3)	1.4 (10)			
BXSA010L6 Compressor: KAJB-010E	BTU/H (Watts)	2210 (650)	3230 (950)	4480 (1310)	5210 (1530)	6010 (1760)	7860 (2300)			
	GPM (L/min)	1.2 (4.5)	1.1 (4.3)	1.2 (4.4)	1.2 (4.7)	1.4 (5.2)	1.8 (6.9)			
	PSIG (kPa)	1.0 (7.1)	1.0 (6.6)	1.0 (7.1)	1.1 (7.8)	1.3 (9.1)	2.0 (14.1)			
BXSA015L6 Compressor: KALB-015E	BTU/H (Watts)	3260 (960)	4830 (1420)	6700 (1960)	7780 (2280)	8950 (2620)	11700 (3430)			
	GPM (L/min)	1.4 (5.2)	1.4 (5.4)	1.7 (6.3)	1.9 (7.3)	2.3 (8.5)	3.3 (12.5)			
	PSIG (kPa)	0.3 (2.4)	0.4 (2.5)	0.5 (3.4)	0.6 (4.3)	0.8 (5.8)	1.6 (11.2)			
BXSA020L6 Compressor: EADB-021E	BTU/H (Watts)	3570 (1050)	5240 (1540)	7480 (2190)	8820 (2580)	10300 (3020)	13800 (4040)			
	GPM (L/min)	1.4 (5.2)	1.5 (5.5)	1.9 (7.1)	2.3 (8.5)	2.8 (10.6)	4.6 (17.3)			
	PSIG (kPa)	0.3 (2.3)	0.4 (2.6)	0.6 (4.1)	0.8 (5.7)	1.2 (8.4)	2.8 (19.5)			
BXSA021L6 Compressor: EAVB-021E	BTU/H (Watts)	4270 (1250)	6330 (1860)	8810 (2580)	10200 (2990)	11800 (3460)	15400 (4510)			
	GPM (L/min)	0.8 (3.2)	1.2 (4.6)	1.9 (7)	2.3 (8.8)	2.9 (11)	4.5 (17)			
	PSIG (kPa)	0.4 (2.8)	0.5 (3.5)	0.8 (5.3)	1.0 (7)	1.4 (9.6)	2.8 (19.4)			
BXSA030L6 Compressor: LAHA-032E	BTU/H (Watts)	5660 (1660)	9130 (2680)	13600 (3990)	16100 (4720)	18900 (5540)	25100 (7360)			
	GPM (L/min)	1.2 (4.7)	1.7 (6.4)	3.1 (11.7)	4.3 (16.2)	5.8 (22.1)	10.4 (39.2)			
	PSIG (kPa)	0.4 (3)	0.7 (4.6)	1.6 (10.8)	2.6 (17.6)	4.2 (29)	10.9 (75.3)			
BXSA031L6 Compressor: NRD1-032E	BTU/H (Watts)	7640 (2240)	12000 (3520)	16600 (4860)	19200 (5630)	22000 (6450)	28800 (8440)			
	GPM (L/min)	4.2 (16)	3.1 (11.8)	3.5 (13.2)	4.3 (16.1)	5.5 (20.9)	10.2 (38.5)			
	PSIG (kPa)	1.6 (11.2)	0.9 (6.2)	1.1 (7.8)	1.6 (11.4)	2.6 (18)	7.3 (50.6)			
BXSA032L6 Compressor: LACA-032E	BTU/H (Watts)	8130 (2380)	12200 (3580)	17200 (5040)	-	-	-	-		
	GPM (L/min)	1.6 (5.9)	2.8 (10.5)	5.3 (20.1)	-	-	-	-		
	PSIG (kPa)	0.6 (4.1)	1.3 (9.3)	3.6 (24.7)	-	-	-	-		

CAPACITY DATA - R22 HIGH TEMPERATURE

Capacity Rating Conditions: 85°F (29.4°C) Entering Water, 105°F (40.6°C) Condensing, 0°F (0°C) Subcooling

MODEL BXSA	SATURATED SUCTION TEMPERATURE °F (°C)								
		0 (-17.8)	10 (-12.2)	20 (-6.7)	25 (-3.9)	30 (-1.1)	35 (1.7)	40 (4.4)	
BXSA005H2 Compressor: HAG2-0050	BTU/H (Watts)	2200 (640)	2890 (850)	3770 (1100)	4270 (1250)	4830 (1420)	6100 (1790)	6820 (2000)	
	GPM (L/min)	0.7 (2.6)	0.8 (3)	1.0 (3.9)	1.3 (4.7)	1.5 (5.8)	2.4 (9)	3.0 (11.3)	
	PSIG (kPa)	0.4 (2.5)	0.4 (2.7)	0.5 (3.6)	0.7 (4.6)	0.9 (6.4)	2.1 (14.6)	3.4 (23.1)	
BXSA008H2 Compressor: KAN2-0075	BTU/H (Watts)	3620 (1060)	4800 (1410)	6250 (1830)	7080 (2070)	7990 (2340)	10000 (2930)	11200 (3280)	
	GPM (L/min)	0.7 (2.7)	1.0 (3.7)	1.4 (5.4)	1.7 (6.5)	2.1 (8)	3.1 (11.8)	3.8 (14.3)	
	PSIG (kPa)	0.4 (2.6)	0.6 (4.2)	1.1 (7.5)	1.5 (10.3)	2.1 (14.2)	4.0 (27.4)	5.5 (37.9)	
BXSA010H2 Compressor: KAR2-0100	BTU/H (Watts)	5190 (1520)	6820 (2000)	8810 (2580)	9950 (2920)	11200 (3280)	13900 (4070)	15400 (4510)	
	GPM (L/min)	1.2 (4.5)	1.4 (5.3)	1.8 (7)	2.2 (8.3)	2.6 (9.9)	3.8 (14.5)	4.6 (17.4)	
	PSIG (kPa)	1.0 (7.2)	1.4 (9.4)	2.1 (14.5)	2.8 (19)	3.7 (25.4)	6.8 (47.2)	9.4 (64.8)	
BXSA015H2 Compressor: KAGB-0150	BTU/H (Watts)	6260 (1830)	8140 (2390)	10600 (3110)	12100 (3550)	13700 (4020)	17200 (5040)	19100 (5600)	
	GPM (L/min)	1.4 (5.5)	1.7 (6.4)	2.2 (8.4)	2.6 (10)	3.2 (12)	4.7 (17.6)	5.6 (21.4)	
	PSIG (kPa)	0.4 (2.6)	0.5 (3.4)	0.8 (5.6)	1.1 (7.5)	1.5 (10.4)	2.9 (20.3)	4.1 (28.5)	
BXSA020H2 Compressor: KAKB-0200	BTU/H (Watts)	8590 (2520)	11600 (3400)	15000 (4400)	16800 (4920)	18800 (5510)	23400 (6860)	25900 (7590)	
	GPM (L/min)	1.3 (5.1)	2.1 (8)	3.2 (12.2)	3.9 (14.9)	4.8 (18.2)	7.0 (26.6)	8.5 (32.2)	
	PSIG (kPa)	0.6 (3.8)	0.9 (6.2)	1.6 (11.3)	2.3 (15.6)	3.2 (21.8)	6.3 (43.3)	8.9 (61.5)	
BXSA030H2 Compressor: ERF1-0310	BTU/H (Watts)	-	19300 (5660)	24900 (7300)	28200 (8260)	31700 (9290)	39500 (11580)	43900 (12870)	
	GPM (L/min)	-	3.3 (12.5)	4.8 (18.3)	6.3 (23.7)	8.2 (31.2)	14.2 (53.8)	18.4 (69.8)	
	PSIG (kPa)	-	1.0 (7.1)	2.1 (14.3)	3.2 (22.3)	5.1 (35.4)	13.0 (89.5)	20.4 (141)	
BXSA040H2 Compressor: NRB2-0400	BTU/H (Watts)	-	25500 (7470)	34200 (10020)	39100 (11460)	44300 (12980)	56200 (16470)	62900 (18430)	
	GPM (L/min)	-	4.7 (17.8)	6.7 (25.3)	8.2 (31.1)	10.2 (38.5)	15.7 (59.5)	19.5 (73.9)	
	PSIG (kPa)	-	1.0 (6.8)	1.8 (12.3)	2.5 (17.6)	3.7 (25.5)	8.1 (55.6)	12.0 (82.4)	

CAPACITY DATA - R22 MEDIUM TEMPERATURE

Capacity Rating Conditions: 85°F (29.4°C) Entering Water, 105°F (40.6°C) Condensing, 0°F (0°C) Subcooling

MODEL BXSA	SATURATED SUCTION TEMPERATURE °F (°C)									
		-5 (-20.6)	0 (-17.8)	5 (-15)	10 (-12.2)	15 (-9.4)	20 (-6.7)	25 (-3.9)	30 (-1.1)	
BXSA005M2 Compressor: HAJ1-0050	BTU/H (Watts)	2170 (640)	2520 (740)	2900 (850)	3310 (970)	3760 (1100)	4260 (1250)	4800 (1410)	-	-
	GPM (L/min)	0.5 (2)	0.6 (2.1)	0.6 (2.2)	0.6 (2.4)	0.7 (2.7)	0.8 (3)	0.9 (3.4)	-	-
	PSIG (kPa)	0.2 (1.7)	0.3 (1.8)	0.3 (1.9)	0.3 (2.2)	0.4 (2.5)	0.4 (3.1)	0.6 (3.8)	-	-
BXSA008M2 Compressor: KAE2-0075	BTU/H (Watts)	3610 (1060)	4170 (1220)	4780 (1400)	5430 (1590)	6150 (1800)	6960 (2040)	7870 (2310)	-	-
	GPM (L/min)	1.1 (4.3)	1.1 (4.3)	1.1 (4.3)	1.2 (4.5)	1.3 (4.8)	1.4 (5.2)	1.6 (5.9)	-	-
	PSIG (kPa)	1.0 (6.7)	1.0 (6.6)	1.0 (6.8)	1.1 (7.3)	1.2 (8)	1.3 (9.2)	1.6 (11)	-	-
BXSA010M2 Compressor: KAM2-0100	BTU/H (Watts)	-	5610 (1640)	6560 (1920)	7590 (2220)	8700 (2550)	9900 (2900)	11200 (3280)	12600 (3690)	
	GPM (L/min)	-	1.2 (4.6)	1.3 (5)	1.5 (5.7)	1.7 (6.6)	2.1 (7.8)	2.5 (9.4)	3.0 (11.4)	
	PSIG (kPa)	-	1.1 (7.4)	1.2 (8.5)	1.5 (10.4)	1.9 (13.2)	2.5 (17.4)	3.4 (23.4)	4.6 (32)	
BXSA021M2 Compressor: ERC1-0200	BTU/H (Watts)	8010 (2350)	9330 (2730)	10800 (3170)	12600 (3690)	14500 (4250)	16600 (4860)	19000 (5570)	-	-
	GPM (L/min)	1.3 (4.9)	1.4 (5.4)	1.7 (6.3)	2.0 (7.5)	2.5 (9.4)	3.1 (11.9)	4.0 (15.3)	-	-
	PSIG (kPa)	0.5 (3.2)	0.5 (3.6)	0.6 (4.5)	0.8 (5.8)	1.1 (7.9)	1.6 (11.1)	2.3 (16.2)	-	-
BXSA030M2 Compressor: 3RA1-0310	BTU/H (Watts)	-	-	20100 (5890)	23000 (6740)	26000 (7620)	29300 (8590)	32900 (9640)	-	-
	GPM (L/min)	-	-	7.0 (26.4)	6.6 (25.1)	6.6 (25)	6.9 (26.1)	7.6 (28.8)	-	-
	PSIG (kPa)	-	-	2.7 (18.4)	2.5 (17.1)	2.5 (17)	2.6 (18.1)	3.1 (21.1)	-	-
BXSA050M2 Compressor: NRM1-0500	BTU/H (Watts)	-	-	33800 (9910)	38300 (11220)	43400 (12720)	48900 (14330)	55000 (16120)	-	-
	GPM (L/min)	-	-	8.0 (30.2)	8.5 (32.4)	9.4 (35.4)	10.5 (39.6)	11.9 (45.2)	-	-
	PSIG (kPa)	-	-	1.7 (11.4)	1.7 (12)	1.9 (12.9)	2.1 (14.4)	2.4 (16.9)	-	-

CAPACITY DATA - R407A

HIGH / MEDIUM TEMPERATURE

Capacity Rating Conditions: 85°F (29.4°C) Entering Water, 105°F (40.6°C) Condensing, 0°F (0°C) Subcooling

MODEL BXZA		SATURATED SUCTION TEMPERATURE °F (°C)									
		-10 (-23.3)	0 (-17.8)	10 (-12.2)	20 (-6.7)	25 (-3.9)	30 (-1.1)	35 (1.7)	40 (4.4)		
BXZA010H8 Compressor: ZS09KAE	BTU/H (Watts)	5340 (1560)	6720 (1970)	8340 (2440)	10300 (3020)	11400 (3340)	12700 (3720)	14100 (4130)	15600 (4570)		
	GPM (L/min)	2.6 (9.8)	2.8 (10.4)	2.4 (9.2)	2.4 (8.9)	2.4 (9.2)	2.7 (10.1)	3.0 (11.5)	3.6 (13.7)		
	PSIG (kPa)	1.5 (10.5)	1.6 (10.8)	1.5 (10.2)	1.5 (10.1)	1.5 (10.2)	1.5 (10.6)	1.6 (11.3)	1.8 (12.3)		
BXZA011H8 Compressor: ZS11KAE	BTU/H (Watts)	6370 (1870)	8030 (2350)	9960 (2920)	12300 (3600)	13600 (3990)	15100 (4430)	16800 (4920)	18600 (5450)		
	GPM (L/min)	2.2 (8.3)	2.4 (9.1)	2.4 (9)	2.7 (10.3)	3.1 (11.7)	3.7 (14)	4.6 (17.3)	5.8 (21.8)		
	PSIG (kPa)	1.4 (9.8)	1.5 (10.2)	1.5 (10.1)	1.6 (10.7)	1.6 (11.4)	1.8 (12.4)	2.0 (13.9)	2.3 (15.9)		
BXZA015H8 Compressor: ZS13KAE	BTU/H (Watts)	7280 (2130)	9170 (2690)	11400 (3340)	14000 (4100)	15600 (4570)	17300 (5070)	19200 (5630)	21300 (6240)		
	GPM (L/min)	2.2 (8.3)	2.6 (9.8)	2.4 (9.2)	2.7 (10.1)	3.0 (11.3)	3.5 (13.3)	4.3 (16.3)	5.4 (20.5)		
	PSIG (kPa)	1.0 (6.6)	1.2 (8.2)	1.1 (7.5)	1.2 (8.5)	1.5 (10.1)	1.9 (13)	2.6 (18.1)	3.9 (26.9)		
BXZA020H8 Compressor: ZB15KCE	BTU/H (Watts)	7640 (2240)	10100 (2960)	12900 (3780)	16200 (4750)	18100 (5300)	20200 (5920)	22500 (6590)	25100 (7360)		
	GPM (L/min)	2.8 (10.6)	3.0 (11.4)	3.1 (11.7)	3.4 (12.8)	3.8 (14.3)	4.4 (16.6)	5.3 (20.1)	6.6 (25.1)		
	PSIG (kPa)	1.4 (9.4)	1.5 (10.4)	1.6 (10.9)	1.8 (12.4)	2.1 (14.6)	2.7 (18.5)	3.6 (24.8)	5.2 (35.6)		
BXZA025H8 Compressor: ZB19KCE	BTU/H (Watts)	8940 (2620)	11900 (3490)	15300 (4480)	19400 (5690)	21700 (6360)	24200 (7090)	26800 (7850)	29700 (8700)		
	GPM (L/min)	2.8 (10.6)	3.0 (11.4)	3.1 (11.7)	3.2 (12.1)	3.3 (12.5)	3.4 (13)	3.8 (14.4)	4.6 (17.3)		
	PSIG (kPa)	0.7 (5)	0.8 (5.8)	0.9 (6.2)	1.0 (6.6)	1.0 (7.1)	1.1 (7.5)	1.3 (9.3)	1.9 (12.9)		
BXZA030H8 Compressor: ZB21KCE	BTU/H (Watts)	11300 (3310)	14900 (4370)	19300 (5660)	24500 (7180)	27400 (8030)	30500 (8940)	33900 (9940)	37500 (10990)		
	GPM (L/min)	2.9 (11)	3.1 (11.7)	3.3 (12.6)	3.7 (14.2)	4.5 (17)	5.7 (21.5)	7.4 (28.1)	9.8 (37)		
	PSIG (kPa)	0.8 (5.4)	0.9 (6.2)	1.0 (7.1)	1.3 (9)	1.8 (12.5)	2.7 (18.9)	4.3 (29.8)	6.9 (47.3)		
BXZA035H8 Compressor: ZB26KCE	BTU/H (Watts)	12900 (3780)	17100 (5010)	21800 (6390)	27300 (8000)	30500 (8940)	34000 (9960)	37900 (11110)	42200 (12370)		
	GPM (L/min)	3.0 (11.4)	3.4 (12.8)	3.5 (13.2)	4.9 (18.4)	6.3 (23.7)	8.3 (31.3)	11.1 (42.1)	15.0 (56.6)		
	PSIG (kPa)	0.8 (5.8)	1.1 (7.3)	1.1 (7.9)	2.1 (14.4)	3.2 (22.2)	5.2 (35.7)	8.5 (58.8)	14.2 (98)		
BXZA040H8 Compressor: ZB30KCE	BTU/H (Watts)	16000 (4690)	21000 (6150)	27200 (7970)	34400 (10080)	38400 (11250)	42800 (12540)	47400 (13890)	52300 (15330)		
	GPM (L/min)	6.6 (25)	7.0 (26.5)	7.4 (28)	7.7 (29.1)	8.7 (33.1)	10.7 (40.4)	13.5 (51.2)	17.5 (66.2)		
	PSIG (kPa)	2.5 (17)	2.7 (18.5)	2.9 (20.1)	3.1 (21.3)	3.8 (26.4)	5.4 (37.2)	8.3 (57.4)	13.6 (93.6)		
BXZA050H8 Compressor: ZB38KCE	BTU/H (Watts)	19600 (5740)	25800 (7560)	33300 (9760)	42200 (12370)	47200 (13830)	52500 (15390)	58200 (17060)	64200 (18820)		
	GPM (L/min)	5.0 (18.9)	5.4 (20.6)	6.1 (23)	8.4 (31.8)	10.4 (39.5)	13.2 (49.9)	16.8 (63.5)	21.3 (80.5)		
	PSIG (kPa)	2.7 (18.5)	2.8 (19.4)	3.0 (20.8)	3.8 (26.2)	4.6 (31.6)	5.8 (39.8)	7.6 (52.4)	10.3 (70.9)		
BXZA060H8 Compressor: ZB45KCE	BTU/H (Watts)	22500 (6590)	29500 (8650)	38100 (11170)	48300 (14160)	54100 (15860)	60200 (17640)	66700 (19550)	---	---	
	GPM (L/min)	4.2 (15.9)	5.1 (19.3)	7.7 (29.2)	12.9 (48.8)	16.3 (61.9)	20.3 (77)	25.0 (94.7)	---	---	
	PSIG (kPa)	0.3 (1.7)	0.5 (3.6)	1.5 (10.1)	3.9 (26.7)	5.9 (40.7)	8.7 (59.7)	12.5 (85.9)	---	---	

NOTES:

- Above ratings are based on mean temperature.
- To convert to dew point ratings, use 0.95 multiplier.

CAPACITY DATA - R407A

LOW TEMPERATURE

Capacity Rating Conditions: 85°F (29.4°C) Entering Water, 105°F (40.6°C) Condensing, 0°F (0°C) Subcooling

MODEL BXZA		SATURATED SUCTION TEMPERATURE °F (°C)									
		-40 (-40)	-35 (-37.2)	-30 (-34.4)	-25 (-31.7)	-20 (-28.9)	-15 (-26.1)	-10 (-23.3)	-5 (-20.6)		
BXZA020L8 Compressor: ZF06K4E	BTU/H (Watts)	3950 (1160)	4570 (1340)	5270 (1540)	6040 (1770)	6890 (2020)	7820 (2290)	8830 (2590)	9930 (2910)		
	GPM (L/min)	2.6 (9.8)	2.8 (10.6)	2.6 (9.9)	2.5 (9.5)	2.5 (9.5)	2.6 (9.9)	2.9 (11)	3.4 (12.9)		
	PSIG (kPa)	1.1 (7.4)	1.2 (8.4)	1.1 (7.5)	1.0 (6.9)	1.0 (6.9)	1.1 (7.5)	1.3 (9)	1.7 (11.7)		
BXZA025L8 Compressor: ZF08K4E	BTU/H (Watts)	4870 (1430)	5650 (1660)	6510 (1910)	7460 (2190)	8510 (2490)	9660 (2830)	10900 (3190)	12300 (3600)		
	GPM (L/min)	2.2 (8.3)	2.4 (9.1)	2.6 (9.8)	2.7 (10.2)	2.8 (10.7)	3.0 (11.3)	3.3 (12.6)	3.9 (14.9)		
	PSIG (kPa)	1.0 (6.6)	1.1 (7.4)	1.2 (8.2)	1.3 (8.7)	1.3 (9.3)	1.5 (10.1)	1.7 (12)	2.3 (15.6)		
BXZA030L8 Compressor: ZF09K4E	BTU/H (Watts)	5500 (1610)	6290 (1840)	7250 (2120)	8360 (2450)	9580 (2810)	10900 (3190)	12200 (3580)	13600 (3990)		
	GPM (L/min)	2.3 (8.7)	2.4 (9.1)	2.7 (10.2)	2.8 (10.7)	3.0 (11.3)	3.4 (12.7)	3.9 (14.7)	4.6 (17.5)		
	PSIG (kPa)	1.0 (7)	1.1 (7.4)	1.3 (8.7)	1.3 (9.3)	1.5 (10.1)	1.8 (12.1)	2.2 (15.2)	3.0 (20.4)		
BXZA035L8 Compressor: ZF11K4E	BTU/H (Watts)	6830 (2000)	7790 (2280)	9000 (2640)	10400 (3050)	11900 (3490)	13600 (3990)	15300 (4480)	17000 (4980)		
	GPM (L/min)	2.8 (10.6)	3.0 (11.4)	3.1 (11.8)	3.3 (12.5)	3.7 (14.1)	4.4 (16.7)	5.4 (20.4)	6.6 (25)		
	PSIG (kPa)	1.4 (9.4)	1.5 (10.4)	1.6 (11)	1.7 (12)	2.1 (14.2)	2.7 (18.6)	3.7 (25.4)	5.1 (35.2)		
BXZA045L8 Compressor: ZF13K4E	BTU/H (Watts)	7830 (2290)	8820 (2580)	10100 (2960)	11600 (3400)	13400 (3930)	15300 (4480)	17500 (5130)	19700 (5770)		
	GPM (L/min)	3.1 (11.8)	3.2 (12.1)	3.4 (13)	3.9 (14.8)	4.8 (18.1)	6.0 (22.8)	7.9 (29.8)	10.2 (38.5)		
	PSIG (kPa)	1.6 (11)	1.6 (11.3)	1.8 (12.6)	2.2 (15.5)	3.1 (21.1)	4.4 (30.5)	6.9 (47.3)	10.6 (72.9)		
BXZA055L8 Compressor: ZF15K4E	BTU/H (Watts)	9890 (2900)	11100 (3250)	12600 (3690)	14500 (4250)	16500 (4840)	18900 (5540)	21500 (6300)	24300 (7120)		
	GPM (L/min)	3.0 (11.4)	3.3 (12.5)	3.5 (13.2)	3.5 (13.4)	4.0 (15)	4.9 (18.7)	6.6 (24.8)	8.9 (33.6)		
	PSIG (kPa)	0.8 (5.8)	1.0 (7)	1.1 (7.9)	1.2 (8)	1.4 (10)	2.2 (14.8)	3.5 (24.1)	5.8 (40.2)		
BXZA060L8 Compressor: ZF18K4E	BTU/H (Watts)	12000 (3520)	13500 (3960)	15300 (4480)	17500 (5130)	20100 (5890)	22800 (6680)	25900 (7590)	---	---	
	GPM (L/min)	3.5 (13.1)	3.6 (13.6)	4.0 (15.3)	5.0 (19)	6.8 (25.7)	9.3 (35.1)	12.9 (48.8)	---	---	
	PSIG (kPa)	1.1 (7.7)	1.2 (8.2)	1.5 (10.3)	2.2 (15.2)	3.7 (25.5)	6.3 (43.4)	11.0 (75.9)	---	---	

NOTES:

- Above ratings are based on mean temperature.
- To convert to dew point ratings, use 0.95 multiplier.

Capacity Rating Conditions: 85°F (29.4°C) Entering Water, 105°F (40.6°C) Condensing, 0°F (0°C) Subcooling

MODEL BXZA		SATURATED SUCTION TEMPERATURE °F (°C)									
		-10 (-23.3)	0 (-17.8)	10 (-12.2)	20 (-6.7)	25 (-3.9)	30 (-1.1)	35 (1.7)	40 (4.4)		
BXZA010H8 Compressor: ZS09KAE	BTU/H (Watts)	5040 (1480)	6290 (1840)	7860 (2300)	9840 (2880)	11000 (3220)	12300 (3600)	13700 (4020)	15300 (4480)		
	GPM (L/min)	2.6 (9.8)	2.8 (10.6)	2.5 (9.3)	2.4 (8.9)	2.4 (9.2)	2.6 (10)	3.0 (11.4)	3.6 (13.7)		
	PSIG (kPa)	1.5 (10.5)	1.6 (10.8)	1.5 (10.3)	1.5 (10)	1.5 (10.2)	1.5 (10.5)	1.6 (11.2)	1.8 (12.3)		
BXZA011H8 Compressor: ZS11KAE	BTU/H (Watts)	6050 (1770)	7550 (2210)	9440 (2770)	11800 (3460)	13200 (3870)	14800 (4340)	16500 (4840)	18400 (5390)		
	GPM (L/min)	2.2 (8.3)	2.5 (9.3)	2.4 (8.9)	2.6 (9.9)	3.0 (11.3)	3.6 (13.6)	4.5 (16.9)	5.7 (21.6)		
	PSIG (kPa)	1.4 (9.8)	1.5 (10.2)	1.5 (10.1)	1.5 (10.5)	1.6 (11.2)	1.8 (12.2)	2.0 (13.7)	2.3 (15.8)		
BXZA015H8 Compressor: ZS13KAE	BTU/H (Watts)	6980 (2050)	8690 (2550)	10700 (3140)	13300 (3900)	14800 (4340)	16600 (4860)	18600 (5450)	20900 (6130)		
	GPM (L/min)	2.2 (8.3)	2.6 (10)	2.4 (9.3)	2.6 (9.8)	2.8 (10.8)	3.3 (12.6)	4.1 (15.5)	5.3 (19.9)		
	PSIG (kPa)	1.0 (6.6)	1.2 (8.4)	1.1 (7.6)	1.2 (8.1)	1.4 (9.4)	1.7 (11.9)	2.4 (16.7)	3.7 (25.6)		
BXZA020H8 Compressor: ZB15KCE	BTU/H (Watts)	7620 (2230)	9410 (2760)	12100 (3550)	15600 (4570)	17700 (5190)	20000 (5860)	22500 (6590)	25200 (7390)		
	GPM (L/min)	2.8 (10.6)	3.0 (11.4)	3.1 (11.7)	3.3 (12.5)	3.7 (13.9)	4.3 (16.3)	5.3 (20)	6.6 (25.1)		
	PSIG (kPa)	1.4 (9.4)	1.5 (10.4)	1.6 (10.9)	1.7 (11.9)	2.0 (14)	2.6 (17.9)	3.6 (24.6)	5.2 (35.6)		
BXZA025H8 Compressor: ZB19KCE	BTU/H (Watts)	10200 (2990)	12200 (3580)	15300 (4480)	19500 (5710)	22100 (6480)	24800 (7270)	27900 (8180)	31100 (9110)		
	GPM (L/min)	2.8 (10.6)	3.0 (11.4)	3.1 (11.7)	3.2 (12.1)	3.3 (12.6)	3.5 (13.4)	4.2 (15.8)	5.3 (19.9)		
	PSIG (kPa)	0.7 (5)	0.8 (5.8)	0.9 (6.2)	1.0 (6.6)	1.0 (7.1)	1.2 (8.1)	1.6 (11)	2.4 (16.5)		
BXZA030H8 Compressor: ZB21KCE	BTU/H (Watts)	12300 (3600)	14600 (4280)	18400 (5390)	23500 (6890)	26500 (7770)	29800 (8730)	33500 (9820)	37400 (10960)		
	GPM (L/min)	2.9 (11)	3.1 (11.7)	3.3 (12.7)	3.6 (13.6)	4.2 (16)	5.4 (20.4)	7.2 (27.3)	9.8 (37)		
	PSIG (kPa)	0.8 (5.4)	0.9 (6.2)	1.0 (7.2)	1.2 (8.3)	1.6 (11.3)	2.5 (17.2)	4.1 (28.3)	6.9 (47.3)		
BXZA035H8 Compressor: ZB26KCE	BTU/H (Watts)	14300 (4190)	17000 (4980)	21400 (6270)	27400 (8030)	30900 (9060)	34800 (10200)	39000 (11430)	43600 (12780)		
	GPM (L/min)	3.0 (11.4)	3.3 (12.6)	3.5 (13.4)	5.1 (19.3)	6.7 (25.3)	9.1 (34.3)	12.4 (46.8)	16.8 (63.7)		
	PSIG (kPa)	0.8 (5.8)	1.0 (7.1)	1.2 (8.1)	2.3 (15.6)	3.6 (24.9)	6.0 (41.7)	10.2 (70.6)	17.4 (120.2)		
BXZA040H8 Compressor: ZB30KCE	BTU/H (Watts)	15300 (4480)	20600 (6040)	26500 (7770)	33200 (9730)	37100 (10870)	41200 (12070)	45700 (13390)	50600 (14830)		
	GPM (L/min)	6.6 (25)	7.0 (26.5)	7.5 (28.3)	7.5 (28.3)	8.3 (31.5)	9.9 (37.4)	12.4 (46.8)	16.0 (60.6)		
	PSIG (kPa)	2.5 (17)	2.7 (18.5)	3.0 (20.5)	3.0 (20.5)	3.5 (24.3)	4.7 (32.5)	7.0 (48.6)	11.4 (78.9)		
BXZA050H8 Compressor: ZB38KCE	BTU/H (Watts)	19100 (5600)	25700 (7530)	33000 (9670)	41500 (12160)	46300 (13570)	51400 (15060)	57100 (16730)	63200 (18520)		
	GPM (L/min)	5.0 (18.9)	5.5 (20.6)	6.1 (23.2)	8.3 (31.5)	10.2 (38.7)	12.8 (48.4)	16.3 (61.7)	20.8 (78.8)		
	PSIG (kPa)	2.7 (18.5)	2.8 (19.4)	3.0 (20.8)	3.8 (25.9)	4.5 (31)	5.6 (38.6)	7.3 (50.7)	10.0 (68.9)		
BXZA060H8 Compressor: ZB45KCE	BTU/H (Watts)	22600 (6620)	30500 (8940)	39200 (11490)	49300 (14450)	54900 (16090)	61100 (17910)	67800 (19870)	---		
	GPM (L/min)	4.2 (15.9)	5.1 (19.3)	8.4 (31.8)	13.7 (51.8)	17.1 (64.6)	21.2 (80.3)	26.1 (98.9)	---		
	PSIG (kPa)	0.3 (1.7)	0.5 (3.6)	1.7 (12)	4.3 (29.7)	6.4 (43.9)	9.3 (64.3)	13.5 (92.8)	---		

NOTES:

- Above ratings are based on mean temperature.
- To convert to dew point ratings, use 0.95 multiplier.

For R449A, use R448A data.

Capacity Rating Conditions: 85°F (29.4°C) Entering Water, 105°F (40.6°C) Condensing, 0°F (0°C) Subcooling

MODEL BXZA	SATURATED SUCTION TEMPERATURE °F (°C)											
		-40 (-40)	-35 (-37.2)	-30 (-34.4)	-25 (-31.7)	-20 (-28.9)	-15 (-26.1)	-10 (-23.3)	-5 (-20.6)			
BXZA020L8 Compressor: ZF06K4E	BTU/H (Watts)	4040 (1180)	4700 (1380)	5420 (1590)	6190 (1810)	7030 (2060)	7950 (2330)	8950 (2620)	10000 (2930)			
	GPM (L/min)	2.6 (9.8)	2.8 (10.7)	2.6 (10)	2.5 (9.5)	2.5 (9.4)	2.6 (9.9)	2.9 (10.9)	3.4 (12.8)			
	PSIG (kPa)	1.1 (7.4)	1.2 (8.5)	1.1 (7.6)	1.0 (7)	1.0 (6.9)	1.1 (7.4)	1.3 (8.8)	1.7 (11.6)			
BXZA025L8 Compressor: ZF08K4E	BTU/H (Watts)	5190 (1520)	5990 (1760)	6860 (2010)	7830 (2290)	8900 (2610)	10100 (2960)	11400 (3340)	12800 (3750)			
	GPM (L/min)	2.2 (8.3)	2.4 (9.1)	2.6 (9.8)	2.7 (10.2)	2.8 (10.7)	3.0 (11.5)	3.4 (13)	4.1 (15.6)			
	PSIG (kPa)	1.0 (6.6)	1.1 (7.4)	1.2 (8.2)	1.3 (8.7)	1.4 (9.3)	1.5 (10.3)	1.8 (12.6)	2.4 (16.8)			
BXZA030L8 Compressor: ZF09K4E	BTU/H (Watts)	5850 (1710)	6720 (1970)	7680 (2250)	8740 (2560)	9900 (2900)	11200 (3280)	12600 (3690)	14100 (4130)			
	GPM (L/min)	2.3 (8.7)	2.4 (9.1)	2.7 (10.2)	2.9 (10.8)	3.1 (11.6)	3.4 (13)	4.1 (15.4)	5.0 (18.8)			
	PSIG (kPa)	1.0 (7)	1.1 (7.4)	1.3 (8.7)	1.4 (9.4)	1.5 (10.4)	1.8 (12.5)	2.4 (16.5)	3.4 (23.2)			
BXZA035L8 Compressor: ZF11K4E	BTU/H (Watts)	7280 (2130)	8350 (2450)	9540 (2800)	10900 (3190)	12300 (3600)	13900 (4070)	15700 (4600)	17700 (5190)			
	GPM (L/min)	2.8 (10.6)	3.0 (11.4)	3.1 (11.9)	3.3 (12.7)	3.7 (14.1)	4.4 (16.7)	5.4 (20.6)	7.0 (26.4)			
	PSIG (kPa)	1.4 (9.4)	1.5 (10.4)	1.6 (11.1)	1.8 (12.2)	2.1 (14.4)	2.7 (18.5)	3.7 (25.8)	5.6 (38.5)			
BXZA045L8 Compressor: ZF13K4E	BTU/H (Watts)	8340 (2440)	9530 (2790)	10900 (3190)	12500 (3660)	14300 (4190)	16300 (4780)	18400 (5390)	20800 (6100)			
	GPM (L/min)	3.5 (13.3)	3.8 (14.4)	4.3 (16.2)	5.0 (19)	6.1 (23)	7.6 (28.8)	9.6 (36.2)	12.3 (46.6)			
	PSIG (kPa)	1.9 (13.1)	2.1 (14.8)	2.6 (17.7)	3.3 (22.6)	4.5 (30.9)	6.5 (44.5)	9.5 (65.6)	14.7 (101.6)			
BXZA055L8 Compressor: ZF15K4E	BTU/H (Watts)	10500 (3080)	12000 (3520)	13700 (4020)	15600 (4570)	17700 (5190)	20100 (5890)	22700 (6650)	25600 (7500)			
	GPM (L/min)	3.0 (11.4)	3.3 (12.5)	3.7 (13.9)	4.1 (15.6)	5.0 (18.7)	6.3 (23.9)	8.3 (31.4)	11.1 (42.2)			
	PSIG (kPa)	0.8 (5.8)	1.0 (7)	1.3 (8.6)	1.6 (10.8)	2.2 (14.9)	3.3 (22.6)	5.2 (35.8)	8.6 (59.1)			
BXZA060L8 Compressor: ZF18K4E	BTU/H (Watts)	12800 (3750)	14600 (4280)	16700 (4890)	18900 (5540)	21500 (6300)	24300 (7120)	27300 (8000)	---	---		
	GPM (L/min)	4.1 (15.7)	4.7 (17.9)	5.7 (21.6)	7.1 (26.8)	9.2 (34.9)	12.1 (45.9)	16.0 (60.6)	---	---		
	PSIG (kPa)	1.6 (10.8)	2.0 (13.7)	2.8 (19)	4.0 (27.4)	6.2 (42.8)	9.9 (68.4)	16.0 (110.3)	---	---		

NOTES:

- Above ratings are based on mean temperature.
 - To convert to dew point ratings, use 0.95 multiplier.
- For R449A, use R448A data.

**CAPACITY DATA - R407C
HIGH / MEDIUM TEMPERATURE**

Capacity Rating Conditions: 85°F (29.4°C) Entering Water, 105°F (40.6°C) Condensing, 0°F (0°C) Subcooling

MODEL BXZA	SATURATED SUCTION TEMPERATURE °F (°C)								
		10 (-12.2)	15 (-9.4)	20 (-6.7)	25 (-3.9)	30 (-1.1)	35 (1.7)	40 (4.4)	
BXZA010H8 Compressor: ZS09KAE	BTU/H (Watts)	7620 (2230)	8630 (2530)	9690 (2840)	10800 (3170)	12000 (3520)	13300 (3900)	14700 (4310)	
	GPM (L/min)	2.2 (8.4)	2.7 (10.1)	3.1 (11.9)	3.7 (14)	4.3 (16.3)	5.0 (19.1)	5.8 (22.1)	
	PSIG (kPa)	0.8 (5.7)	1.1 (7.7)	1.5 (10.2)	2.0 (13.5)	2.6 (17.7)	3.4 (23.4)	4.4 (30.5)	
BXZA011H8 Compressor: ZS11KAE	BTU/H (Watts)	9100 (2670)	10300 (3020)	11600 (3400)	12900 (3780)	14400 (4220)	15900 (4660)	17500 (5130)	
	GPM (L/min)	3.1 (11.8)	3.7 (14)	4.4 (16.6)	5.2 (19.6)	6.1 (23)	7.1 (26.7)	8.2 (31)	
	PSIG (kPa)	1.4 (10)	2.0 (13.6)	2.6 (18.2)	3.6 (24.5)	4.7 (32.7)	6.3 (43.2)	8.3 (57)	
BXZA015H8 Compressor: ZS13KAE	BTU/H (Watts)	10400 (3050)	11800 (3460)	13200 (3870)	14800 (4340)	16400 (4810)	18100 (5300)	20000 (5860)	
	GPM (L/min)	3.2 (12.3)	3.9 (14.8)	4.7 (17.8)	5.6 (21.3)	6.7 (25.2)	7.9 (29.7)	9.2 (34.8)	
	PSIG (kPa)	1.6 (11.4)	2.3 (15.6)	3.1 (21.3)	4.2 (29.2)	5.7 (39.2)	7.7 (52.8)	10.2 (70.3)	
BXZA020H8 Compressor: ZB15KCE	BTU/H (Watts)	11700 (3430)	13200 (3870)	14800 (4340)	16600 (4860)	18400 (5390)	20500 (6010)	22700 (6650)	
	GPM (L/min)	3.1 (11.6)	3.8 (14.2)	4.6 (17.4)	5.6 (21.2)	6.8 (25.6)	8.2 (30.9)	9.8 (37.2)	
	PSIG (kPa)	1.6 (10.8)	2.1 (14.6)	2.9 (19.7)	3.9 (26.9)	5.3 (36.7)	7.3 (50.2)	10.0 (68.8)	
BXZA025H8 Compressor: ZB19KCE	BTU/H (Watts)	12900 (3780)	14700 (4310)	16700 (4890)	18900 (5540)	21200 (6210)	23800 (6980)	26700 (7820)	
	GPM (L/min)	1.3 (4.9)	2.0 (7.5)	2.8 (10.7)	3.9 (14.8)	5.2 (19.9)	6.9 (26)	8.9 (33.5)	
	PSIG (kPa)	0.3 (2)	0.5 (3.3)	0.8 (5.3)	1.2 (8.4)	1.9 (13)	2.9 (19.7)	4.3 (29.8)	
BXZA030H8 Compressor: ZB21KCE	BTU/H (Watts)	17400 (5100)	19600 (5740)	22100 (6480)	24700 (7240)	27600 (8090)	30800 (9030)	34200 (10020)	
	GPM (L/min)	4.1 (15.7)	5.4 (20.5)	7.0 (26.4)	8.9 (33.5)	11.1 (42.2)	13.9 (52.6)	17.2 (65)	
	PSIG (kPa)	1.3 (9.1)	2.0 (13.6)	2.9 (20.2)	4.3 (29.8)	6.3 (43.8)	9.3 (63.9)	13.5 (93)	
BXZA035H8 Compressor: ZB26KCE	BTU/H (Watts)	21000 (6150)	23400 (6860)	26300 (7710)	29600 (8670)	33100 (9700)	36900 (10810)	40800 (11960)	
	GPM (L/min)	5.4 (20.5)	6.5 (24.6)	7.9 (30)	9.7 (36.8)	11.9 (45.1)	14.4 (54.6)	17.3 (65.5)	
	PSIG (kPa)	2.1 (14.5)	2.8 (19.3)	3.9 (26.6)	5.4 (37.3)	7.6 (52.5)	10.6 (73.4)	14.7 (101.3)	
BXZA040H8 Compressor: ZB30KCE	BTU/H (Watts)	23300 (6830)	26300 (7710)	29500 (8650)	33100 (9700)	37000 (10840)	41200 (12070)	45700 (13390)	
	GPM (L/min)	7.4 (28.2)	8.8 (33.5)	10.5 (39.7)	12.4 (47.1)	14.8 (55.9)	17.5 (66.1)	20.7 (78.2)	
	PSIG (kPa)	2.9 (20.2)	3.9 (27)	5.3 (36.4)	7.1 (49.1)	9.7 (66.6)	13.1 (90.6)	17.9 (123.4)	
BXZA050H8 Compressor: ZB38KCE	BTU/H (Watts)	30300 (8880)	34000 (9960)	38200 (11200)	42700 (12510)	47500 (13920)	52600 (15420)	58100 (17030)	
	GPM (L/min)	9.8 (37)	12.2 (46)	15.0 (56.8)	18.4 (69.8)	22.5 (85.1)	27.3 (103.2)	32.9 (124.4)	
	PSIG (kPa)	2.5 (17)	3.4 (23.3)	4.7 (32.1)	6.4 (44.3)	8.9 (61.1)	12.2 (84.1)	16.8 (115.7)	
BXZA060H8 Compressor: ZB45KCE	BTU/H (Watts)	34700 (10170)	39100 (11460)	43900 (12870)	49000 (14360)	54500 (15970)	60400 (17700)	66900 (19610)	
	GPM (L/min)	10.8 (40.9)	12.9 (48.9)	15.4 (58.2)	18.3 (69.2)	21.7 (82)	25.7 (97.2)	30.4 (115.1)	
	PSIG (kPa)	3.4 (23.4)	4.5 (30.8)	5.9 (40.7)	7.8 (53.9)	10.4 (71.6)	13.9 (95.7)	18.6 (128.3)	

NOTE: The capacities shown above are rated at dew point. The dew point is a saturation point and is the condition (pressure and temperature) at which a gas begins to condense. Since R407C has significant glide, the saturated gas and saturated liquid temperatures are not the same. It is important that all components of a system are selected correctly

Capacity Rating Conditions: 85°F (29.4°C) Entering Water, 105°F (40.6°C) Condensing, 0°F (0°C) Subcooling

MODEL BXZA	SATURATED SUCTION TEMPERATURE °F (°C)									
	-10 (-23.3)	0 (-17.8)	10 (-12.2)	20 (-6.7)	25 (-3.9)	30 (-1.1)	35 (1.7)	40 (4.4)		
BXZA010H8 Compressor: ZS09KAE	BTU/H (Watts)	5530 (1620)	6990 (2050)	8670 (2540)	10700 (3140)	11900 (3490)	13200 (3870)	14600 (4280)	16200 (4750)	
	GPM (L/min)	0.8 (3.1)	1.2 (4.4)	1.6 (6)	2.2 (8.2)	2.5 (9.5)	2.9 (11.1)	3.4 (13)	4.0 (15.2)	
	PSIG (kPa)	0.2 (1.3)	0.3 (2.1)	0.5 (3.3)	0.8 (5.4)	1.0 (7)	1.3 (9.1)	1.7 (11.9)	2.3 (15.7)	
BXZA011H8 Compressor: ZS11KAE	BTU/H (Watts)	6700 (1960)	8470 (2480)	10500 (3080)	13000 (3810)	14400 (4220)	16000 (4690)	17700 (5190)	19700 (5770)	
	GPM (L/min)	1.2 (4.5)	1.6 (6.2)	2.3 (8.6)	3.1 (11.7)	3.6 (13.7)	4.2 (16)	5.0 (18.7)	5.8 (22)	
	PSIG (kPa)	0.3 (2.1)	0.5 (3.5)	0.9 (5.9)	1.4 (9.9)	1.9 (13)	2.5 (17.1)	3.3 (22.7)	4.4 (30.3)	
BXZA015H8 Compressor: ZS13KAE	BTU/H (Watts)	7620 (2230)	9630 (2820)	12000 (3520)	14700 (4310)	16400 (4810)	18200 (5330)	20200 (5920)	22400 (6560)	
	GPM (L/min)	1.0 (3.9)	1.5 (5.8)	2.2 (8.4)	3.1 (11.9)	3.7 (14.1)	4.4 (16.8)	5.3 (19.9)	6.3 (23.7)	
	PSIG (kPa)	0.3 (2)	0.5 (3.5)	0.9 (6.1)	1.6 (10.7)	2.1 (14.3)	2.8 (19.2)	3.8 (25.9)	5.1 (35)	
BXZA020H8 Compressor: ZB15KCE	BTU/H (Watts)	8420 (2470)	10900 (3190)	13800 (4040)	17100 (5010)	19000 (5570)	21000 (6150)	23100 (6770)	25400 (7440)	
	GPM (L/min)	1.2 (4.5)	1.7 (6.4)	2.4 (9.1)	3.4 (12.8)	4.0 (15.1)	4.8 (18.1)	5.7 (21.5)	6.7 (25.5)	
	PSIG (kPa)	0.4 (3)	0.7 (4.7)	1.1 (7.6)	1.8 (12.4)	2.3 (16)	3.0 (21)	4.0 (27.6)	5.3 (36.4)	
BXZA025H8 Compressor: ZB19KCE	BTU/H (Watts)	11100 (3250)	14000 (4100)	17400 (5100)	21400 (6270)	23600 (6920)	26000 (7620)	28500 (8350)	31200 (9140)	
	GPM (L/min)	0.8 (3)	1.2 (4.5)	1.8 (6.9)	2.8 (10.4)	3.4 (12.9)	4.2 (15.9)	5.2 (19.5)	6.3 (24)	
	PSIG (kPa)	0.2 (1.1)	0.3 (1.8)	0.4 (2.9)	0.7 (5.1)	1.0 (6.9)	1.3 (9.3)	1.8 (12.6)	2.5 (17.3)	
BXZA030H8 Compressor: ZB21KCE	BTU/H (Watts)	13400 (3930)	16900 (4950)	20900 (6130)	25700 (7530)	28400 (8320)	31200 (9140)	34300 (10050)	37500 (10990)	
	GPM (L/min)	1.3 (5)	2.0 (7.6)	3.1 (11.6)	4.6 (17.6)	5.7 (21.7)	7.1 (26.7)	8.7 (32.8)	10.7 (40.3)	
	PSIG (kPa)	0.3 (2)	0.5 (3.4)	0.9 (5.9)	1.6 (10.8)	2.2 (14.8)	3.0 (20.6)	4.2 (28.8)	5.9 (40.6)	
BXZA035H8 Compressor: ZB26KCE	BTU/H (Watts)	15600 (4570)	19700 (5770)	24400 (7150)	30000 (8790)	33000 (9670)	36400 (10670)	39900 (11690)	43800 (12840)	
	GPM (L/min)	1.8 (6.8)	2.7 (10.1)	3.9 (14.7)	5.6 (21.1)	6.6 (25.1)	7.9 (29.8)	9.3 (35.2)	11.0 (41.5)	
	PSIG (kPa)	0.4 (3.1)	0.8 (5.2)	1.3 (8.8)	2.2 (15.1)	2.9 (19.9)	3.8 (26.2)	5.0 (34.6)	6.6 (45.7)	
BXZA040H8 Compressor: ZB30KCE	BTU/H (Watts)	17900 (5250)	22500 (6590)	28000 (8210)	34300 (10050)	37900 (11110)	41700 (12220)	45800 (13420)	50200 (14710)	
	GPM (L/min)	3.3 (12.6)	4.4 (16.8)	5.9 (22.5)	8.0 (30.1)	9.2 (34.8)	10.6 (40.3)	12.3 (46.5)	14.2 (53.7)	
	PSIG (kPa)	0.8 (5.6)	1.3 (8.7)	2.0 (13.9)	3.3 (22.5)	4.2 (28.9)	5.4 (37.2)	7.0 (48)	9.0 (62.1)	
BXZA050H8 Compressor: ZB38KCE	BTU/H (Watts)	22300 (6540)	28100 (8240)	34900 (10230)	42900 (12570)	47300 (13860)	52000 (15240)	57200 (16760)	62600 (18350)	
	GPM (L/min)	2.9 (10.9)	4.5 (17)	6.8 (25.7)	10.0 (37.9)	12.1 (45.6)	14.4 (54.7)	17.2 (65.2)	20.5 (77.5)	
	PSIG (kPa)	0.5 (3.5)	0.9 (6)	1.5 (10.2)	2.5 (17.6)	3.3 (23)	4.4 (30.3)	5.8 (39.8)	7.6 (52.4)	
BXZA060H8 Compressor: ZB45KCE	BTU/H (Watts)	26500 (7770)	33400 (9790)	41500 (12160)	50900 (14920)	56200 (16470)	61800 (18110)	67900 (19900)	74400 (21800)	
	GPM (L/min)	4.7 (17.9)	6.4 (24.3)	8.7 (32.9)	11.8 (44.6)	13.7 (51.8)	15.9 (60.2)	18.5 (69.9)	21.4 (81)	
	PSIG (kPa)	1.0 (7.2)	1.6 (10.9)	2.5 (16.9)	3.9 (26.7)	4.9 (33.8)	6.2 (43)	7.9 (54.8)	10.2 (70.1)	

HIGH / MEDIUM TEMPERATURE

Capacity Rating Conditions: 85°F (29.4°C) Entering Water, 105°F (40.6°C) Condensing, 0°F (0°C) Subcooling

MODEL BXZA	SATURATED SUCTION TEMPERATURE °F (°C)									
	10 (-12.2)	15 (-9.4)	20 (-6.7)	25 (-3.9)	30 (-1.1)	35 (1.7)	40 (4.4)	45 (7.2)		
BXZA010H8 Compressor: ZS09KAE	BTU/H (Watts)	8490 (2490)	9510 (2790)	10600 (3110)	11800 (3460)	13000 (3810)	14300 (4190)	15800 (4630)	17400 (5100)	
	GPM (L/min)	1.4 (5.4)	1.7 (6.4)	2.0 (7.6)	2.4 (9)	2.8 (10.5)	3.3 (12.4)	3.8 (14.5)	4.5 (17)	
	PSIG (kPa)	0.4 (2.8)	0.5 (3.7)	0.7 (4.8)	0.9 (6.3)	1.2 (8.3)	1.6 (10.9)	2.1 (14.4)	2.8 (19.1)	
BXZA011H8 Compressor: ZS11KAE	BTU/H (Watts)	9990 (2930)	11200 (3280)	12500 (3660)	13800 (4040)	15300 (4480)	16900 (4950)	18600 (5450)	20400 (5980)	
	GPM (L/min)	2.0 (7.4)	2.3 (8.8)	2.8 (10.5)	3.3 (12.3)	3.8 (14.5)	4.5 (17.1)	5.3 (20.1)	6.2 (23.5)	
	PSIG (kPa)	0.7 (4.7)	0.9 (6.2)	1.2 (8.2)	1.6 (10.9)	2.1 (14.4)	2.8 (19.3)	3.7 (25.7)	4.9 (34.1)	
BXZA015H8 Compressor: ZS13KAE	BTU/H (Watts)	11500 (3370)	12900 (3780)	14300 (4190)	15900 (4660)	17600 (5160)	19400 (5690)	21300 (6240)	23500 (6890)	
	GPM (L/min)	1.9 (7.3)	2.3 (8.8)	2.8 (10.6)	3.4 (12.8)	4.1 (15.4)	4.8 (18.4)	5.8 (21.8)	6.9 (25.9)	
	PSIG (kPa)	0.7 (5)	1.0 (6.6)	1.3 (9)	1.8 (12.2)	2.4 (16.6)	3.3 (22.4)	4.4 (30.3)	6.0 (41.3)	
BXZA020H8 Compressor: ZB15KCE	BTU/H (Watts)	13300 (3900)	14900 (4370)	16700 (4890)	18600 (5450)	20600 (6040)	22700 (6650)	25000 (7330)	27400 (8030)	
	GPM (L/min)	1.9 (7.4)	2.4 (9)	2.9 (11)	3.5 (13.4)	4.3 (16.2)	5.1 (19.5)	6.2 (23.4)	7.4 (28.1)	
	PSIG (kPa)	0.8 (5.7)	1.1 (7.5)	1.4 (10)	1.9 (13.3)	2.6 (17.7)	3.4 (23.6)	4.6 (31.8)	6.2 (42.8)	
BXZA025H8 Compressor: ZB19KCE	BTU/H (Watts)	14900 (4370)	16700 (4890)	18700 (5480)	20800 (6100)	23100 (6770)	25500 (7470)	28100 (8240)	31000 (9090)	
	GPM (L/min)	1.2 (4.6)	1.5 (5.8)	1.9 (7.3)	2.4 (9.1)	3.0 (11.4)	3.8 (14.3)	4.7 (17.9)	5.9 (22.4)	
	PSIG (kPa)	0.3 (1.8)	0.3 (2.4)	0.5 (3.2)	0.6 (4.3)	0.8 (5.8)	1.2 (8)	1.6 (11.1)	2.3 (15.6)	
BXZA030H8 Compressor: ZB21KCE	BTU/H (Watts)	19400 (5690)	21700 (6360)	24300 (7120)	27000 (7910)	29900 (8760)	33000 (9670)	36400 (10670)	39900 (11690)	
	GPM (L/min)	2.3 (8.7)	2.9 (11.1)	3.7 (14.1)	4.7 (17.8)	5.9 (22.5)	7.5 (28.3)	9.4 (35.5)	11.7 (44.3)	
	PSIG (kPa)	0.6 (4)	0.8 (5.5)	1.1 (7.8)	1.6 (11)	2.3 (15.7)	3.3 (22.6)	4.7 (32.7)	6.9 (47.5)	
BXZA035H8 Compressor: ZB26KCE	BTU/H (Watts)	22500 (6590)	25200 (7390)	28100 (8240)	31200 (9140)	34600 (10140)	38100 (11170)	42000 (12310)	46200 (13540)	
	GPM (L/min)	3.0 (11.4)	3.7 (13.9)	4.5 (17)	5.5 (20.8)	6.7 (25.2)	8.0 (30.4)	9.7 (36.6)	11.6 (43.7)	
	PSIG (kPa)	0.9 (6.1)	1.2 (8.1)	1.6 (10.9)	2.1 (14.8)	2.9 (20)	3.9 (27.1)	5.3 (36.8)	7.2 (49.9)	
BXZA040H8 Compressor: ZB30KCE	BTU/H (Watts)	26300 (7710)	29500 (8650)	32900 (9640)	36600 (10730)	40600 (11900)	44800 (13130)	49300 (14450)	54100 (15860)	
	GPM (L/min)	5.1 (19.2)	6.0 (22.7)	7.1 (26.7)	8.3 (31.5)	9.8 (37.1)	11.5 (43.5)	13.4 (50.9)	15.7 (59.4)	
	PSIG (kPa)	1.6 (10.8)	2.0 (14.1)	2.7 (18.5)	3.5 (24.4)	4.7 (32.2)	6.2 (42.6)	8.2 (56.3)	10.8 (74.5)	
BXZA050H8 Compressor: ZB38KCE	BTU/H (Watts)	32300 (9470)	36300 (10640)	40500 (11870)	45100 (13220)	49900 (14620)	55100 (16150)	60700 (17790)	66600 (19520)	
	GPM (L/min)	5.3 (19.9)	6.6 (25.2)	8.3 (31.4)	10.3 (38.9)	12.6 (47.7)	15.3 (58.1)	18.6 (70.3)	22.3 (84.5)	
	PSIG (kPa)	1.1 (7.3)	1.4 (9.9)	2.0 (13.5)	2.6 (18.2)	3.6 (24.6)	4.8 (33.3)	6.5 (44.9)	8.8 (60.4)	
BXZA060H8 Compressor: ZB45KCE	BTU/H (Watts)	38900 (11400)	43500 (12750)	48400 (14180)	53900 (15800)	59700 (17500)	65900 (19310)	72600 (21280)	79700 (23360)	
	GPM (L/min)	7.3 (27.5)	8.6 (32.6)	10.2 (38.5)	12.1 (45.7)	14.3 (54)	16.8 (63.7)	19.8 (75)	23.2 (88)	
	PSIG (kPa)	1.9 (13.1)	2.4 (16.7)	3.1 (21.4)	4.0 (27.7)	5.2 (36.1)	6.8 (47.1)	8.9 (61.6)	11.7 (80.7)	

CAPACITY DATA - R404A R507

LOW TEMPERATURE

Capacity Rating Conditions: 85°F (29.4°C) Entering Water, 105°F (40.6°C) Condensing, 0°F (0°C) Subcooling

MODEL BXZA	SATURATED SUCTION TEMPERATURE °F (°C)										
	-40 (-40)	-30 (-34.4)	-25 (-31.7)	-20 (-28.9)	-15 (-26.1)	-10 (-23.3)	-5 (-20.6)	0 (-17.8)			
BXZA020L6 Compressor: ZF06K4E	BTU/H (Watts)	4470 (1310)	5910 (1730)	6690 (1960)	7530 (2210)	8430 (2470)	9400 (2750)	10500 (3080)	11600 (3400)		
	GPM (L/min)	1.1 (4)	1.4 (5.2)	1.6 (5.9)	1.8 (6.8)	2.1 (7.9)	2.4 (9.2)	2.8 (10.7)	3.3 (12.5)		
	PSIG (kPa)	0.3 (1.8)	0.4 (2.6)	0.5 (3.3)	0.6 (4.1)	0.7 (5.2)	1.0 (6.6)	1.2 (8.5)	1.6 (11.1)		
BXZA025L6 Compressor: ZF08K4E	BTU/H (Watts)	5780 (1690)	7500 (2200)	8470 (2480)	9530 (2790)	10700 (3140)	11900 (3490)	13300 (3900)	14800 (4340)		
	GPM (L/min)	1.1 (4.3)	1.5 (5.8)	1.8 (6.9)	2.1 (8.1)	2.5 (9.6)	3.0 (11.3)	3.5 (13.4)	4.2 (15.9)		
	PSIG (kPa)	0.3 (2.3)	0.5 (3.6)	0.7 (4.5)	0.8 (5.9)	1.1 (7.6)	1.4 (10)	1.9 (13.2)	2.5 (17.5)		
BXZA030L6 Compressor: ZF09K4E	BTU/H (Watts)	6380 (1870)	8270 (2420)	9330 (2730)	10500 (3080)	11800 (3460)	13200 (3870)	14700 (4310)	16300 (4780)		
	GPM (L/min)	1.1 (4.3)	1.6 (6.2)	2.0 (7.4)	2.3 (8.8)	2.8 (10.5)	3.3 (12.5)	3.9 (14.9)	4.7 (17.7)		
	PSIG (kPa)	0.3 (2.3)	0.6 (3.9)	0.7 (5.1)	1.0 (6.7)	1.3 (8.8)	1.7 (11.7)	2.3 (15.7)	3.1 (21.1)		
BXZA035L6 Compressor: ZF11K4E	BTU/H (Watts)	7900 (2320)	10200 (2990)	11500 (3370)	12900 (3780)	14500 (4250)	16200 (4750)	18100 (5300)	20200 (5920)		
	GPM (L/min)	1.3 (5.1)	1.9 (7.4)	2.3 (8.9)	2.8 (10.7)	3.4 (12.8)	4.1 (15.5)	4.9 (18.6)	5.9 (22.4)		
	PSIG (kPa)	0.5 (3.5)	0.8 (5.7)	1.1 (7.3)	1.4 (9.5)	1.8 (12.5)	2.4 (16.5)	3.2 (22)	4.3 (29.6)		
BXZA045L6 Compressor: ZF13K4E	BTU/H (Watts)	9010 (2640)	11600 (3400)	13100 (3840)	14800 (4340)	16600 (4860)	18600 (5450)	20800 (6100)	23200 (6800)		
	GPM (L/min)	2.7 (10.2)	3.6 (13.5)	4.1 (15.6)	4.8 (18.2)	5.6 (21.3)	6.6 (24.9)	7.7 (29.3)	9.1 (34.5)		
	PSIG (kPa)	1.3 (8.9)	1.9 (13.4)	2.4 (16.8)	3.1 (21.2)	3.9 (27.1)	5.1 (35)	6.6 (45.8)	8.8 (60.5)		
BXZA055L6 Compressor: ZF15K4E	BTU/H (Watts)	11200 (3280)	14600 (4280)	16500 (4840)	18500 (5420)	20700 (6070)	23200 (6800)	25900 (7590)	28800 (8440)		
	GPM (L/min)	1.8 (6.8)	2.7 (10.1)	3.2 (12.3)	4.0 (15)	4.8 (18.3)	5.9 (22.4)	7.3 (27.5)	8.9 (33.9)		
	PSIG (kPa)	0.4 (2.9)	0.7 (4.9)	0.9 (6.4)	1.2 (8.5)	1.7 (11.4)	2.3 (15.6)	3.1 (21.6)	4.4 (30.3)		
BXZA060L6 Compressor: ZF18K4E	BTU/H (Watts)	13300 (3900)	17300 (5070)	19500 (5710)	22000 (6450)	24800 (7270)	27700 (8120)	31000 (9090)	34500 (10110)		
	GPM (L/min)	2.2 (8.2)	3.5 (13.2)	4.4 (16.7)	5.6 (21)	7.0 (26.5)	8.8 (33.5)	11.1 (42.2)	14.0 (53.1)		
	PSIG (kPa)	0.5 (3.7)	1.0 (7.1)	1.4 (10)	2.1 (14.2)	3.0 (20.4)	4.3 (29.7)	6.3 (43.8)	9.4 (65.1)		

MODEL BXHA	COMPRESSOR MODEL NO.	POWER SUPPLY	COMPRESSOR		UNIT		
			RLA	LRA	MCA	MOP	
BXHA005H7-	IS1	RST45C1E-CAA	115/1/60	9.4	54.5	11.8	20
	IS2	RST45C1E-CAV	208-230/1/60	4.6	26.5	5.8	15
BXHA008H7-	IS1	RST55C1E-CAA	115/1/60	13.5	70.0	16.9	30
	IS2	RST55C1E-CAV	208-230/1/60	6.1	33.7	7.6	15
BXHA010H7-	IS2	RST70C1E-PFV	208-230/1/60	6.9	46.0	8.6	15
	IT3	RST70C1E-TA5	208-230/3/60	4.9	36.0	6.1	15
BXHA015H7-	IS2	CR18K6E-PFV	208-230/1/60	9.4	49.0	11.8	20
	IT3	CR18K6E-TF5	208-230/3/60	5.4	49.0	6.8	15
BXHA020H7-	IS2	CR24K6E-PFV	208-230/1/60	11.2	61.0	14.0	25
	IT3	CR24K6E-TF5	208-230/3/60	6.9	55.0	8.6	15
	IT4	CR24K6E-TFD	460/3/60	3.6	28.0	4.5	15
BXHA025H7-	IS2	CR32K6E-PFV	208-230/1/60	14.4	82.0	18.0	30
	IT3	CR32K6E-TF5	208-230/3/60	9.0	72.0	11.3	20
	IT4	CR32K6E-TFD	460/3/60	4.6	33.0	5.7	15
BXHA030H7-	IS2	CR38K6E-PFV	208-230/1/60	17.1	105.0	21.4	35
	IT3	CR38K6E-TF5	208-230/3/60	10.7	85.0	13.4	20
	IT4	CR38K6E-TFD	460/3/60	5.3	42.0	6.6	15
BXHA035H7-	IS2	CR42K6E-PFV	208-230/1/60	18.3	102.0	22.9	40
	IT3	CR42K6E-TF5	208-230/3/60	12.6	91.0	15.8	25
	IT4	CR42K6E-TFD	460/3/60	5.7	42.0	7.1	15
	IT5	CR42K6E-TFE	575/3/60	4.7	39.0	5.8	15
BXHA040H7-	IS2	CR53KQE-PFV	208-230/1/60	26.0	140.0	32.5	50
	IT3	CR53KQE-TF5	208-230/3/60	16.3	107.0	20.4	35
	IT4	CR53KQE-TFD	460/3/60	8.1	55.0	10.2	15
BXHA050H7-	IS2	CRNQ-050E-PFV	208-230/1/60	30.8	142.0	38.5	60
	IT3	CRNQ-050E-TF5	208-230/3/60	19.2	130.0	24.0	40
	IT4	CRNQ-050E-TFD	460/3/60	8.7	65.0	10.8	20
	IT5	CRNQ-050E-TFE	575/3/60	7.1	52.0	8.8	15
BXHA006E6-	IS1	RST45C1E-CAA	115/1/60	9.4	54.5	11.8	20
	IS2	RST45C1E-CAV	208-230/1/60	4.6	26.5	5.8	15
BXHA008E6-	IS1	RST55C1E-CAA	115/1/60	13.5	70.0	16.9	30
	IS2	RST55C1E-CAV	208-230/1/60	6.1	33.7	7.6	15
BXHA009E6-	IS1	RST64C1E-CAA	115/1/60	13.1	77.0	16.4	25
	IS2	RST64C1E-CAV	208-230/1/60	8.0	43.0	10.0	15
BXHA010E6-	IS2	RST70C1E-PFV	208-230/1/60	6.9	46.0	8.6	15
	IT3	RST70C1E-TA5	208-230/3/60	4.9	36.0	6.1	15
BXHA015E6-	IS2	CS10K6E-PFV	208-230/1/60	9.8	56.0	12.3	20
	IT3	CS10K6E-TF5	208-230/3/60	6.7	51.0	8.4	15
	IT4	CS10K6E-TFD	460/3/60	3.2	25.0	4.0	15
BXHA020E6-	IS2	CS12K6E-PFV	208-230/1/60	9.8	56.0	12.3	20
	IT3	CS12K6E-TF5	208-230/3/60	6.7	51.0	8.4	15
BXHA025E6-	IS2	CS14K6E-PFV	208-230/1/60	11.2	61.0	14.0	25
	IT3	CS14K6E-TF5	208-230/3/60	8.2	55.0	10.3	15
	IT4	CS14K6E-TFD	460/3/60	4.2	28.0	5.3	15
BXHA030E6-	IS2	CS18K6E-PFV	208-230/1/60	14.4	82.0	17.9	30
	IT3	CS18K6E-TF5	208-230/3/60	7.9	65.5	9.9	15
	IT4	CS18K6E-TFD	460/3/60	4.2	33.0	5.3	15
BXHA035E6-	IS2	CS20K6E-PFV	208-230/1/60	16.7	96.0	20.8	35
	IT3	CS20K6E-TF5	208-230/3/60	10.2	75.0	12.8	20
	IT4	CS20K6E-TFD	460/3/60	4.6	40.0	5.7	15
BXHA040E6-	IS2	CS27K6E-PFV	208-230/1/60	21.5	95.4	26.8	45
	IT3	CS27K6E-TF5	208-230/3/60	14.0	82.0	17.5	30
	IT4	CS27K6E-TFD	460/3/60	7.6	41.0	9.5	15
BXHA050E6-	IS2	CS33K6E-PFV	208-230/1/60	27.6	125.0	34.5	60
	IT3	CS33K6E-TF5	208-230/3/60	16.8	102.0	21.0	35
	IT4	CS33K6E-TFD	460/3/60	8.8	48.0	11.1	15
BXHA006L6-	IS1	RFT22C1E-CAA	115/1/60	7.1	54.5	8.9	15
	IS2	RFT22C1E-CAV	208-230/1/60	4.7	29.0	5.9	15
BXHA008L6-	IS1	RFT26C1E-CAA	115/1/60	9.7	66.0	12.1	20
	IS2	RFT26C1E-CAV	208-230/1/60	5.8	35.5	7.3	15
BXHA010L6-	IS2	CF04K6E-PFV	208-230/1/60	9.9	59.2	12.4	20
	IT3	CF04K6E-TF5	208-230/3/60	6.1	52.0	7.6	15
BXHA020L6-	IS2	CF06K6E-PFV	208-230/1/60	10.3	59.2	12.8	20
	IT3	CF06K6E-TF5	208-230/3/60	6.3	52.0	7.9	15
BXHA025L6-	IS2	CF09K6E-PFV	208-230/1/60	15.0	87.0	18.8	30
	IT3	CF09K6E-TF5	208-230/3/60	9.2	72.2	11.5	20
	IT4	CF09K6E-TFD	460/3/60	4.9	35.8	6.2	15
BXHA030L6-	IS2	CF12K6E-PFV	208-230/1/60	18.4	105.0	23.0	40
	IT3	CF12K6E-TF5	208-230/3/60	11.0	85.0	13.8	20
	IT4	CF12K6E-TFD	460/3/60	5.9	42.0	7.4	15

Above listed RLA value is based on UL rating method and may differ from published compressor RLA data.

MODEL BXSA	COMPRESSOR MODEL NO.	POWER SUPPLY	COMPRESSOR		UNIT		
			RLA	LRA	MCA	MOP	
BXSA008H2-	IS2	KAN2-0075-CAV	208-230/1/60	6.1	36	7.6	15
	IT3	KAN1-0075-TAC	208-230/3/60	3.5	19.9	4.4	15
BXSA010H2-	IS2	KAR2-0100-CAV	208-230/1/60	7.4	40	9.3	15
	IT3	KAR1-0100-TAC	208-230/3/60	4.3	27	5.4	15
BXSA015H2-	IS2	KAGB-0150-CAV	208-230/1/60	9.6	55	12.0	20
	IT3	KAGA-0150-TAC	208-230/3/60	5.5	35.5	6.9	15
	IT4	KAGA-0150-TAD	460/3/60	2.5	18.2	3.1	15
BXSA020H2-	IS2	KAKB-0200-CAV	208-230/1/60	10.6	55	13.3	20
	IT3	KAKA-0200-TAC	208-230/3/60	6.8	50	8.5	15
	IT4	KAKA-0200-TAD	460/3/60	3.0	25	3.8	15
BXSA030H2-	IS3	ERF2-0310-CAB	230/1/60	17.0	86	21.3	35
	IT3	ERF1-0310-TAC	208-230/3/60	11.7	82	14.6	25
	IT4	ERF1-0310-TAD	460/3/60	6.4	41	8.0	15
BXSA008M2-	IS2	KAE2-0075-CAV	208-230/1/60	5.4	36	6.8	15
	IT3	KAE1-0075-TAC	208-230/3/60	3.4	19.9	4.3	15
BXSA010M2-	IS2	KAM2-0100-CAV	208-230/1/60	7.5	40	9.4	15
	IT3	KAM1-0100-TAC	208-230/3/60	4.5	27	5.6	15
BXSA021M2-	IS3	ERC2-0200-CAB	230/1/60	10.9	58	13.6	20
	IT3	ERC1-0200-TAC	208-230/3/60	6.8	46	8.5	15
	IT4	ERC1-0200-TAD	460/3/60	3.6	23	4.5	15
	IT5	ERC1-0200-TAE	575/3/60	3.2	20	4.0	15
BXSA010M6-	IS2	KARB-010E-CAV	208-230/1/60	7.4	40	9.3	15
	IT3	KARA-010E-TAC	208-230/3/60	4.3	27	5.4	15
BXSA020M6-	IS2	KAKB-021E-CAV	208-230/1/60	10.6	55	13.3	20
	IT3	KAKA-020E-TAC	208-230/3/60	6.8	50	8.5	15
	IT4	KAKA-022E-TAD	460/3/60	3.0	25	3.8	15
BXSA021M6-	IT3	ERCA-021E-TAC	208-230/3/60	8.8	46	11.0	15
	IT4	ERCA-020E-TAD	460/3/60	3.5	23	4.4	15
	IT5	ERCA-020E-TAE	575/3/60	3.1	20	3.9	15
BXSA030M6-	IS3	ERFB-031E-CAB	230/1/60	17.0	86	21.3	35
	IT3	ERFA-031E-TAC	208-230/3/60	12.4	82	15.5	25
	IT4	ERFA-031E-TAD	460/3/60	5.8	41	7.3	15
BXSA035M6-	IT3	3RAA-031E-TAC	208-230/3/60	14.2	82	17.8	30
	IT4	3RAA-031E-TAD	460/3/60	6.3	41	7.9	15
BXSA040M6-	IT3	NRB2-040E-TFC	208-230/3/60	21.8	141	27.3	45
	IT4	NRB2-040E-TFD	460/3/60	9.0	63	11.3	20
BXSA005L6-	IS2	KANB-005E-CAV	208-230/1/60	3.6	24	4.5	15
	IT3	KANA-006E-TAC	208-230/3/60	2.2	13.2	2.8	15
BXSA008L6-	IS2	KAMB-007E-CAV	208-230/1/60	5.6	36	7.0	15
	IT3	KAMA-007E-TAC	208-230/3/60	3.2	19.9	4.0	15
BXSA010L6-	IS2	KAJB-010E-CAV	208-230/1/60	6.9	40	8.6	15
	IT3	KAJA-011E-TAC	208-230/3/60	4.6	27	5.8	15
BXSA015L6-	IS2	KALB-015E-CAV	208-230/1/60	9.9	55	12.4	20
	IT3	KALA-016E-TAC	208-230/3/60	6.6	50	8.3	15
	IT4	KALA-016E-TAD	460/3/60	3.4	25	4.3	15
BXSA020L6-	IS3	EADB-021E-CAB	230/1/60	10.0	58	12.5	20
	IT3	EADA-020E-TAC	208-230/3/60	6.8	46	8.5	15
BXSA021L6-	IS2	EAVB-021E-CAV	208-230/1/60	14.7	102	18.4	30
	IT3	EAVA-021E-TAC	208-230/3/60	7.4	50	9.3	15
	IT4	EAVA-021E-TAD	460/3/60	3.9	26.6	4.9	15
	IT5	EAVA-021E-TAE	575/3/60	3.1	20	3.9	15
BXSA030L6-	IS3	LAHB-032E-CAB	230/1/60	16.7	105	20.9	35
	IT3	LAHB-032E-TAC	208-230/3/60	12.8	112	16.0	25
	IT4	LAHB-032E-TAD	460/3/60	6.0	56	7.5	15
	IT5	LAHB-032E-TAE	575/3/60	4.1	30	5.1	15
BXSA032L6-	IS3	LACB-032E-CAB	230/1/60	15.5	105	19.4	30
	IT3	LACB-032E-TAC	208-230/3/60	12.8	112	16.0	25
	IT4	LACB-032E-TAD	460/3/60	6.0	56	7.5	15

Above listed RLA value is based on UL rating method and may differ from published compressor RLA data.

MODEL BXZA	COMPRESSOR MODEL NO.	POWER SUPPLY	COMPRESSOR		UNIT		
			RLA	LRA	MCA	MOP	
BXZA010H8-	IS2	ZS09KAE-PFV	208-230/1/60	10.0	40.3	12.5	20
	IT3	ZS09KAE-TF5	208-230/3/60	8.0	55.4	10.0	15
	IT4	ZS09KAE-TFD	460/3/60	3.8	28	4.8	15
BXZA011H8-	IS2	ZS11KAE-PFV	208-230/1/60	12.6	55	15.8	25
	IT3	ZS11KAE-TF5	208-230/3/60	10.4	58	13.0	20
	IT4	ZS11KAE-TFD	460/3/60	4.3	28	5.4	15
BXZA015H8-	IS2	ZS13KAE-PFV	208-230/1/60	12.0	56	15.0	25
	IT3	ZS13KAE-TF5	208-230/3/60	9.7	58	12.1	20
	IT4	ZS13KAE-TFD	460/3/60	4.8	29	6.0	15
BXZA020H8-	IS2	ZB15KCE-PFV	208-230/1/60	15.7	61	19.6	35
	IT3	ZB15KCE-TF5	208-230/3/60	8.9	55	11.1	20
	IT4	ZB15KCE-TFD	460/3/60	5.0	27	6.3	15
BXZA025H8-	IS2	ZB19KCE-PFV	208-230/1/60	17.9	73	22.4	40
	IT3	ZB19KCE-TF5	208-230/3/60	10.0	63	12.5	20
	IT4	ZB19KCE-TFD	460/3/60	5.0	31	6.3	15
BXZA030H8-	IS2	ZB21KCE-PFV	208-230/1/60	20.7	100	25.9	45
	IT3	ZB21KCE-TF5	208-230/3/60	12.1	77	15.1	25
	IT4	ZB21KCE-TFD	460/3/60	6.1	39	7.6	15
BXZA035H8-	IS2	ZB26KCE-PFV	208-230/1/60	23.6	127	29.5	50
	IT3	ZB26KCE-TF5	208-230/3/60	13.9	88	17.4	30
	IT4	ZB26KCE-TFD	460/3/60	7.1	44	8.9	15
BXZA040H8-	IS2	ZB30KCE-PFV	208-230/1/60	26.8	132	33.5	60
	IT3	ZB30KCE-TF5	208-230/3/60	15.7	115	19.6	35
	IT4	ZB30KCE-TFD	460/3/60	7.5	47.5	9.4	15
	IT5	ZB30KCE-TFE	575/3/60	6.0	38	7.5	15
BXZA050H8-	IS2	ZB38KCE-PFV	208-230/1/60	31.1	175	38.9	70
	IT3	ZB38KCE-TF5	208-230/3/60	22.1	115	27.6	45
	IT4	ZB38KCE-TFD	460/3/60	9.6	63	12.0	20
	IT5	ZB38KCE-TFE	575/3/60	7.7	50	9.6	15
BXZA060H8-	IT3	ZB45KCE-TF5	208-230/3/60	22.5	156	28.1	50
	IT4	ZB45KCE-TFD	460/3/60	11.5	70	14.4	25
	IT5	ZB45KCE-TFE	575/3/60	9.2	56	11.5	20
BXZA020L 6/8-	IS2	ZF06K4E-PFV	208-230/1/60	13.6	61	17.0	30
	IT3	ZF06K4E-TF5	208-230/3/60	9.3	55	11.6	20
BXZA025L 6/8-	IS2	ZF08K4E-PFV	208-230/1/60	16.4	73	20.5	35
	IT3	ZF08K4E-TF5	208-230/3/60	9.7	63	12.1	20
	IT4	ZF08K4E-TFD	460/3/60	5.0	39	6.3	15
BXZA030L 6/8-	IS2	ZF09KCE-PFV	208-230/1/60	16.4	88	20.5	35
	IT3	ZF09KCE-TF5	208-230/3/60	11.1	77	13.9	25
	IT4	ZF09KCE-TFD	460/3/60	5.7	39	7.1	15
	IT5	ZF09KCE-TFE	575/3/60	4.3	31	5.4	15
BXZA035L 6/8-	IS2	ZF11K4E-PFV	208-230/1/60	20.7	109	25.9	45
	IT3	ZF11K4E-TF5	208-230/3/60	13.6	88	17.0	30
	IT4	ZF11K4E-TFD	460/3/60	7.1	44	8.9	15
	IT5	ZF11K4E-TFE	575/3/60	5.0	34	6.3	15
BXZA045L 6/8-	IS2	ZF13K4E-PFV	208-230/1/60	26.8	129	33.5	60
	IT3	ZF13K4E-TF5	208-230/3/60	15.0	99	18.8	30
	IT4	ZF13K4E-TFD	460/3/60	8.2	49.5	10.3	15
	IT5	ZF13K4E-TFE	575/3/60	8.2	40	10.3	15
BXZA055L 6/8-	IS2	ZF15K4E-PFV	208-230/1/60	31.8	169	39.8	70
	IT3	ZF15K4E-TF5	208-230/3/60	21.4	123	26.8	45
	IT4	ZF15K4E-TFD	460/3/60	9.6	62	12.0	20
	IT5	ZF15K4E-TFE	575/3/60	7.9	50	9.9	15
BXZA060L 6/8-	IT3	ZF18K4E-TF5	208-230/3/60	23.9	156	29.9	50
	IT4	ZF18K4E-TFD	460/3/60	9.3	70	11.6	20
	IT5	ZF18K4E-TFE	575/3/60	7.9	54	9.9	15

Above listed RLA value is based on UL rating method and may differ from published compressor RLA data.

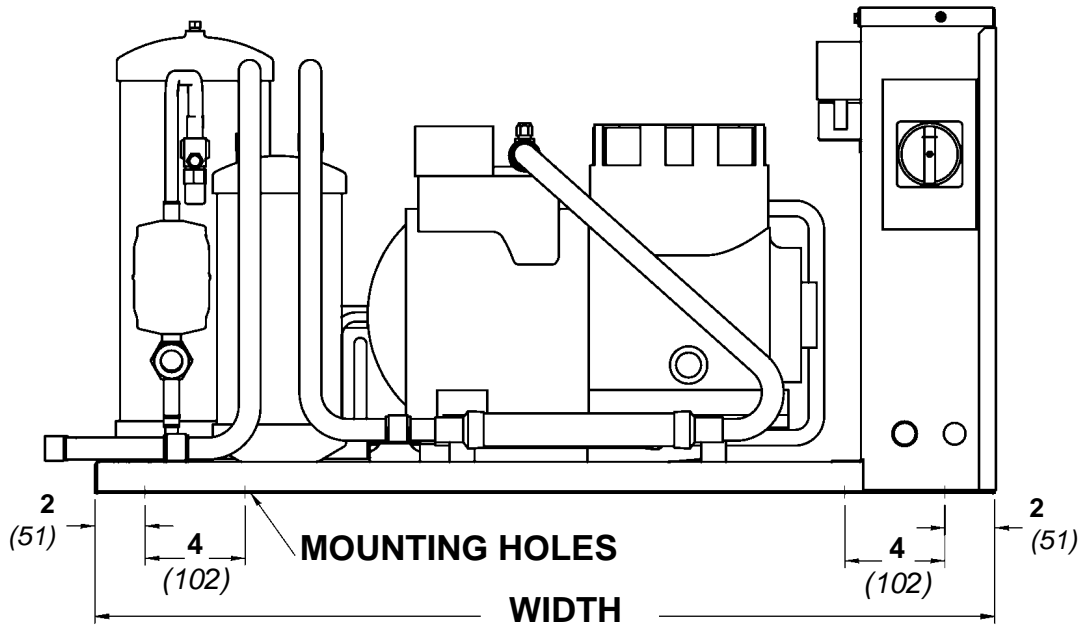
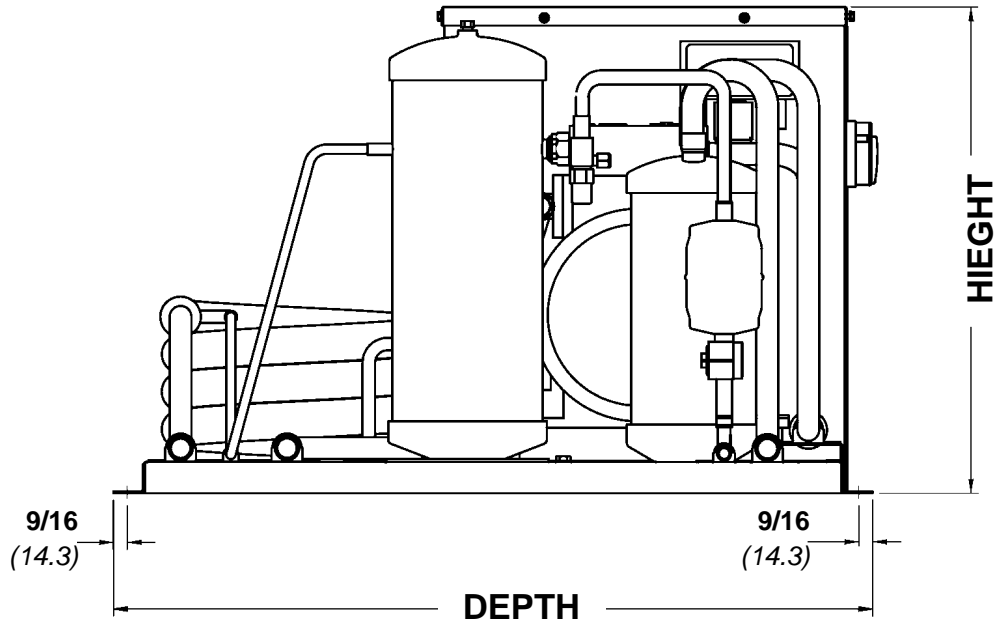

**REFER TO NEXT PAGE FOR
DIMENSIONAL DATA FOR SPECIFIC MODELS**

BXH**DIMENSIONAL DATA****60Hz**

MODEL BXHA	WIDTH		DEPTH		HIEGHT	
	Inches	mm	Inches	mm	Inches	mm
BXHA005H7	24 7/8	632	30 3/8	772	16 1/2	419
BXHA008H7	24 7/8	632	30 3/8	772	16 1/2	419
BXHA010H7	24 7/8	632	30 3/8	772	16 1/2	419
BXHA015H7	36 3/8	924	30 3/8	772	19 1/2	495
BXHA020H7	36 3/8	924	30 3/8	772	19 1/2	495
BXHA025H7	36 3/8	924	30 3/8	772	19 1/2	495
BXHA030H7	43 7/8	1114	32 7/8	835	30	762
BXHA035H7	43 7/8	1114	32 7/8	835	30	762
BXHA040H7	43 7/8	1114	32 7/8	835	30	762
BXHA050H7	43 7/8	1114	32 7/8	835	30	762
BXHA006E6	24 7/8	632	30 3/8	772	16 1/2	419
BXHA008E6	24 7/8	632	30 3/8	772	16 1/2	419
BXHA009E6	24 7/8	632	30 3/8	772	16 1/2	419
BXHA010E6	24 7/8	632	30 3/8	772	16 1/2	419
BXHA015E6	36 3/8	924	30 3/8	772	19 1/2	495
BXHA020E6	36 3/8	924	30 3/8	772	19 1/2	495
BXHA025E6	36 3/8	924	30 3/8	772	19 1/2	495
BXHA030E6	43 7/8	1114	32 7/8	835	30	762
BXHA035E6	43 7/8	1114	32 7/8	835	30	762
BXHA040E6	43 7/8	1114	32 7/8	835	30	762
BXHA050E6	43 7/8	1114	32 7/8	835	30	762
BXHA006L6	24 7/8	632	30 3/8	772	16 1/2	419
BXHA008L6	24 7/8	632	30 3/8	772	16 1/2	419
BXHA010L6	24 7/8	632	30 3/8	772	16 1/2	419
BXHA020L6	24 7/8	632	30 3/8	772	16 1/2	419
BXHA025L6	36 3/8	924	30 3/8	772	19 1/2	495
BXHA030L6	36 3/8	924	30 3/8	772	19 1/2	495

BXS**DIMENSIONAL DATA****60Hz**

MODEL BXSA	WIDTH		DEPTH		HIEGHT	
	Inches	mm	Inches	mm	Inches	mm
BXSA005H2	24 7/8	632	30 3/8	772	16 1/2	419
BXSA008H2	24 7/8	632	30 3/8	772	16 1/2	419
BXSA010H2	24 7/8	632	30 3/8	772	16 1/2	419
BXSA015H2	36 3/8	924	30 3/8	772	19 1/2	495
BXSA020H2	36 3/8	924	30 3/8	772	19 1/2	495
BXSA030H2	43 7/8	1114	32 7/8	835	30	762
BXSA008M2	24 7/8	632	30 3/8	772	16 1/2	419
BXSA010M2	24 7/8	632	30 3/8	772	16 1/2	419
BXSA021M2	36 3/8	924	30 3/8	772	19 1/2	495
BXSA010M6	24 7/8	632	30 3/8	772	16 1/2	419
BXSA020M6	36 3/8	924	30 3/8	772	19 1/2	495
BXSA021M6	36 3/8	924	30 3/8	772	19 1/2	495
BXSA030M6	43 7/8	1114	32 7/8	835	30	762
BXSA005L6	24 7/8	632	30 3/8	772	16 1/2	419
BXSA008L6	24 7/8	632	30 3/8	772	16 1/2	419
BXSA010L6	24 7/8	632	30 3/8	772	16 1/2	419
BXSA015L6	36 3/8	924	30 3/8	772	19 1/2	495
BXSA020L6	36 3/8	924	30 3/8	772	19 1/2	495
BXSA021L6	36 3/8	924	30 3/8	772	19 1/2	495
BXSA030L6	43 7/8	1114	32 7/8	835	30	762
BXSA032L6	43 7/8	1114	32 7/8	835	30	762

BXZ**DIMENSIONAL DATA****60Hz**

MODEL BXZA	WIDTH		DEPTH		HIEGHT	
	Inches	mm	Inches	mm	Inches	mm
BXZA010H8	36 3/8	924	30 3/8	772	19 1/2	495
BXZA011H8	36 3/8	924	30 3/8	772	19 1/2	495
BXZA015H8	36 3/8	924	30 3/8	772	19 1/2	495
BXZA020H8	36 3/8	924	30 3/8	772	19 1/2	495
BXZA025H8	36 3/8	924	30 3/8	772	19 1/2	495
BXZA030H8	43 7/8	1114	32 7/8	835	30	762
BXZA035H8	43 7/8	1114	32 7/8	835	30	762
BXZA040H8	43 7/8	1114	32 7/8	835	30	762
BXZA050H8	43 7/8	1114	32 7/8	835	30	762
BXZA060H8	43 7/8	1114	32 7/8	835	30	762
BXZA020L 6/8	36 3/8	924	30 3/8	772	19 1/2	495
BXZA025L 6/8	36 3/8	924	30 3/8	772	19 1/2	495
BXZA030L 6/8	36 3/8	924	30 3/8	772	19 1/2	495
BXZA035L 6/8	36 3/8	924	30 3/8	772	19 1/2	495
BXZA045L 6/8	43 7/8	1114	32 7/8	835	30	762
BXZA055L 6/8	43 7/8	1114	32 7/8	835	30	762
BXZA060L 6/8	43 7/8	1114	32 7/8	835	30	762

MODEL BXHA	FIELD CONNECTIONS				WATER CONNECTION		RECEIVER CAPACITY 90% FULL *		SHIPPING WEIGHT	
	SUCTION		LIQUID		In.	mm	Lbs.	Kgs	Lbs.	Kgs
	In.	mm	In.	mm						
BXHA005H7	1/2	13	3/8	10	1/2	13	6.0	2.7	110	50
BXHA008H7	5/8	16	3/8	10	1/2	13	6.0	2.7	120	54
BXHA010H7	5/8	16	3/8	10	1/2	13	6.0	2.7	140	64
BXHA015H7	5/8	16	3/8	10	5/8	16	12.0	5.4	240	109
BXHA020H7	5/8	16	3/8	10	3/4	19	12.0	5.4	240	109
BXHA025H7	7/8	22	3/8	10	7/8	22	15.0	6.8	250	113
BXHA030H7	7/8	22	1/2	13	7/8	22	23.0	10.4	330	150
BXHA035H7	7/8	22	1/2	13	7/8	22	23.0	10.4	330	150
BXHA040H7	1 1/8	29	1/2	13	7/8	22	23.0	10.4	340	154
BXHA050H7	1 1/8	29	1/2	13	1 1/8	29	23.0	10.4	350	159
BXHA006E6	5/8	16	3/8	10	1/2	13	5.4	2.4	120	54
BXHA008E6	5/8	16	3/8	10	1/2	13	5.4	2.4	120	54
BXHA009E6	5/8	16	3/8	10	1/2	13	5.4	2.4	120	54
BXHA010E6	5/8	16	3/8	10	1/2	13	5.4	2.4	140	64
BXHA015E6	5/8	16	3/8	10	5/8	16	11.3	5.1	240	109
BXHA020E6	5/8	16	3/8	10	5/8	16	11.3	5.1	240	109
BXHA025E6	7/8	22	1/2	13	3/4	19	14.4	6.5	240	109
BXHA030E6	7/8	22	1/2	13	7/8	22	21.5	9.8	320	145
BXHA035E6	7/8	22	1/2	13	7/8	22	21.5	9.8	320	145
BXHA040E6	7/8	22	1/2	13	7/8	22	21.5	9.8	320	145
BXHA050E6	7/8	22	1/2	13	1 1/8	29	21.5	9.8	330	150
BXHA006L6	1/2	13	3/8	10	1/2	13	5.4	2.4	110	50
BXHA008L6	5/8	16	3/8	10	1/2	13	5.4	2.4	160	73
BXHA010L6	7/8	22	3/8	10	1/2	13	5.4	2.4	160	73
BXHA020L6	7/8	22	3/8	10	1/2	13	5.4	2.4	160	73
BXHA025L6	7/8	22	3/8	10	5/8	16	11.3	5.1	240	109
BXHA030L6	7/8	22	1/2	13	3/4	19	14.4	6.5	250	113

*** NOTE ON ALTERNATE REFRIGERANTS:**

* PUBLISHED RECEIVER CAPACITY IS BASED ON **R404A** ON MODELS USING "8" AS REFRIGERANT CODE.
FOR ALTERNATE REFRIGERANTS, MULTIPLY **R404A** VALUE BY THE APPROPRIATE VALUE BELOW:

R407A	R407C	R448A	R507	R22
1.10	1.10	1.05	1.00	1.15

- For R449A, use R448A data.

MODEL BXSA	FIELD CONNECTIONS				WATER CONNECTION		RECEIVER CAPACITY 90% FULL *		SHIPPING WEIGHT	
	SUCTION		LIQUID		In.	mm	Lbs.	Kgs	Lbs.	Kgs
	Inches	mm	Inches	mm						
BXSA005H2	1/2	13	3/8	10	1/2	13	6	2.7	190	86
BXSA008H2	1/2	13	3/8	10	1/2	13	6	2.7	220	100
BXSA010H2	5/8	16	3/8	10	1/2	13	6	2.7	240	109
BXSA015H2	7/8	22	3/8	10	5/8	16	16	7.3	280	127
BXSA020H2	7/8	22	1/2	13	5/8	16	16	7.3	290	132
BXSA030H2	1 1/8	29	1/2	13	7/8	22	25	11.3	410	186
BXSA008M2	5/8	16	3/8	10	1/2	13	6	2.7	220	100
BXSA010M2	5/8	16	3/8	10	1/2	13	6	2.7	240	109
BXSA021M2	7/8	22	1/2	13	3/4	19	16	7.3	350	159
BXSA010M6	5/8	16	3/8	10	1/2	13	5.4	2.4	240	109
BXSA020M6	7/8	22	1/2	13	5/8	16	14	6.4	290	132
BXSA021M6	7/8	22	1/2	13	3/4	19	14	6.3	350	159
BXSA030M6	7/8	22	1/2	13	7/8	22	22	10.0	410	186
BXSA005L6	1/2	13	3/8	10	1/2	13	5.4	2.4	220	100
BXSA008L6	5/8	16	3/8	10	1/2	13	5.4	2.4	240	109
BXSA010L6	7/8	22	3/8	10	1/2	13	5.4	2.4	260	118
BXSA015L6	7/8	22	3/8	10	5/8	16	14	6.4	280	127
BXSA020L6	7/8	22	3/8	10	5/8	16	14	6.4	350	159
BXSA021L6	7/8	22	1/2	13	5/8	16	14	6.4	350	159
BXSA030L6	1 1/8	29	1/2	13	3/4	19	22	10.0	420	191
BXSA032L6	1 1/8	29	1/2	13	3/4	19	22	10.0	420	191

MODEL BXZA	FIELD CONNECTIONS				WATER CONNECTION		RECEIVER CAPACITY 90% FULL *		SHIPPING WEIGHT	
	SUCTION		LIQUID		In.	mm	Lbs.	Kgs	Lbs.	Kgs
	Inches	mm	Inches	mm						
XZA010H8	5/8	16	3/8	10	5/8	16	5.4	2.4	115	52
XZA011H8	5/8	16	3/8	10	5/8	16	5.4	2.4	125	57
XZA015H8	7/8	22	3/8	10	5/8	16	11.0	5.0	150	68
XZA020H8	7/8	22	3/8	10	3/4	19	11.0	5.0	250	113
XZA025H8	7/8	22	1/2	13	7/8	22	14.0	6.4	250	113
XZA030H8	7/8	22	1/2	13	7/8	22	22.0	10.0	265	120
XZA035H8	7/8	22	1/2	13	7/8	22	22.0	10.0	330	150
XZA040H8	1 1/8	29	1/2	13	7/8	22	22.0	10.0	330	150
XZA050H8	1 1/8	29	1/2	13	7/8	22	22.0	10.0	340	154
XZA060H8	1 1/8	29	1/2	13	1 1/8	29	22.0	10.0	350	159
XZA020L 6/8	7/8	22	3/8	10	5/8	16	11.0	5.0	200	91
XZA025L 6/8	7/8	22	3/8	10	5/8	16	14.0	6.4	220	100
XZA030L 6/8	7/8	22	3/8	10	5/8	16	14.0	6.4	230	104
XZA035L 6/8	7/8	22	1/2	13	3/4	19	22.0	10.0	240	109
XZA045L 6/8	1 1/8	29	1/2	13	3/4	19	22.0	10.0	290	132
XZA055L 6/8	1 1/8	29	1/2	13	7/8	22	22.0	10.0	290	132
XZA060L 6/8	1 1/8	29	1/2	13	7/8	22	22.0	10.0	300	136

*** NOTE ON ALTERNATE REFRIGERANTS:**

* PUBLISHED RECEIVER CAPACITY IS BASED ON **R404A** ON MODELS USING "8" AS REFRIGERANT CODE.
FOR ALERNATE REFRIGERANTS, MULTIPLY **R404A** VALUE BY THE APPROPRIATE VALUE BELOW:

R407A	R407C	R448A	R507	R22
1.10	1.10	1.05	1.00	1.15

- For R449A, use R448A data.

TYPICAL SYSTEM WIRING DIAGRAM

208-230/3/60 Unit with Single Air Defrost Evaporator

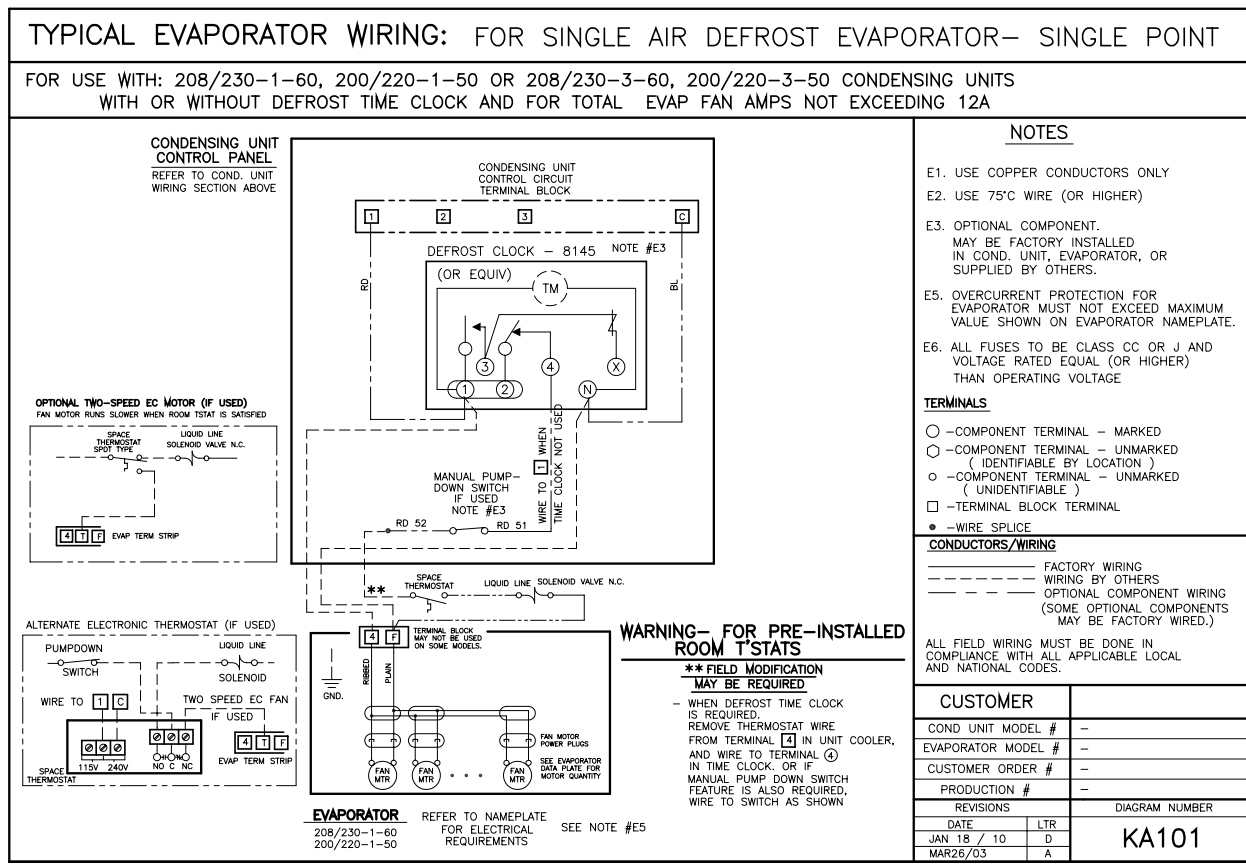
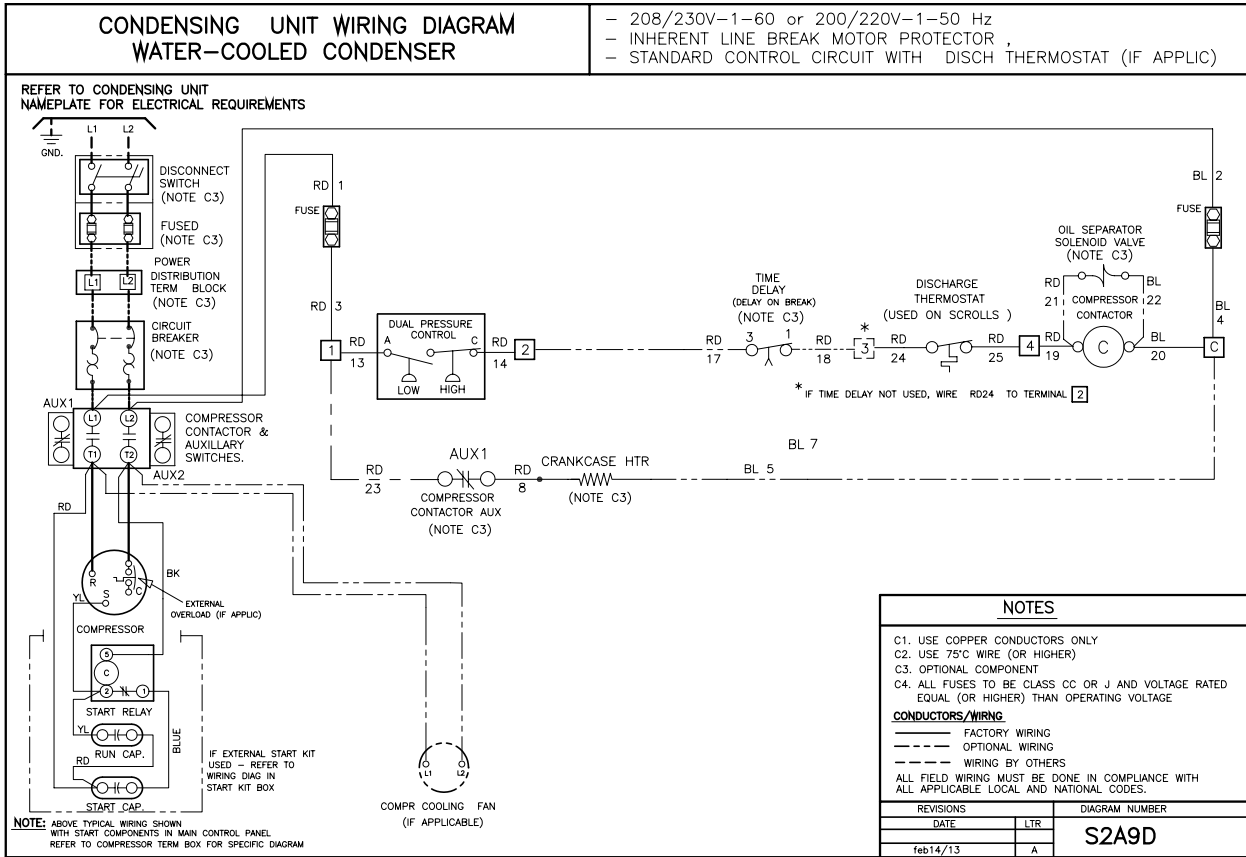

TYPICAL SYSTEM WIRING DIAGRAM

208-230/3/60 Unit

with Single Low Profile Electric Defrost Evaporator

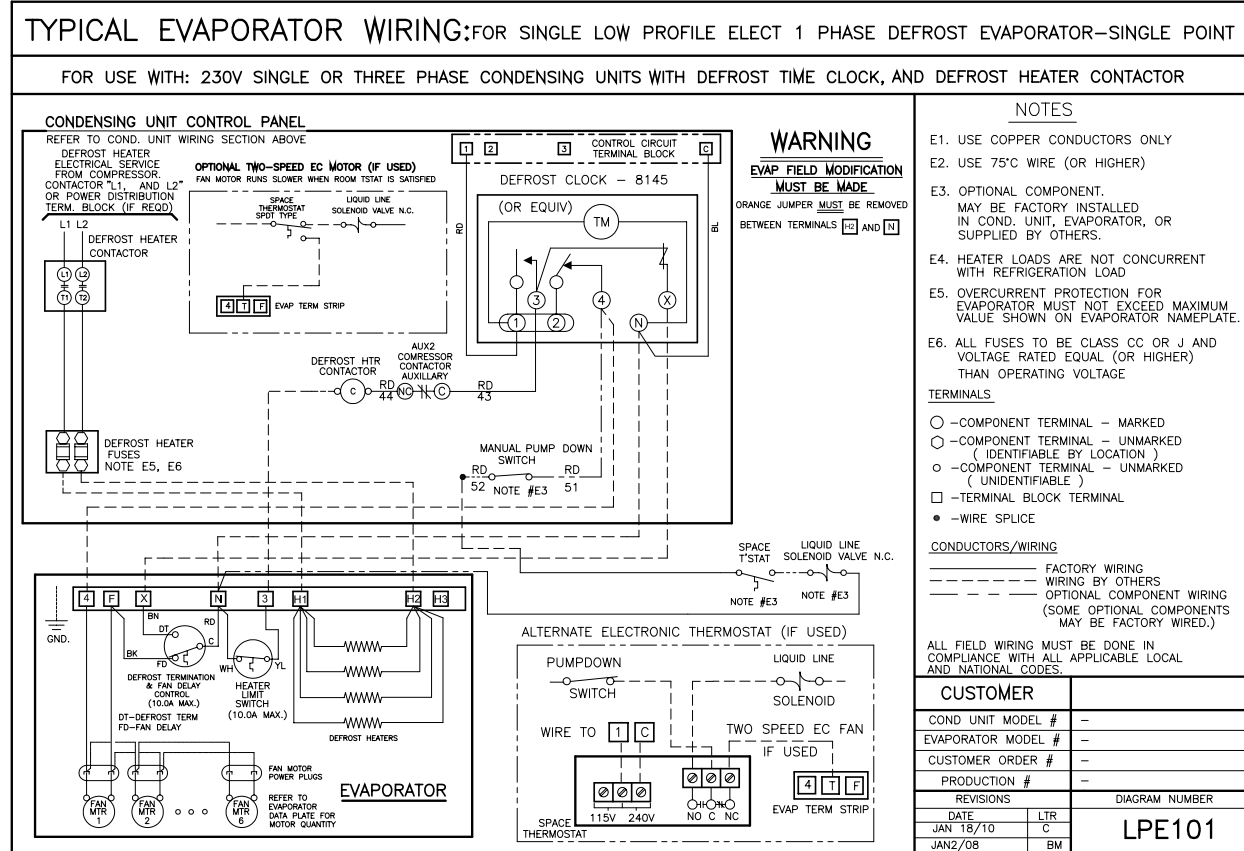
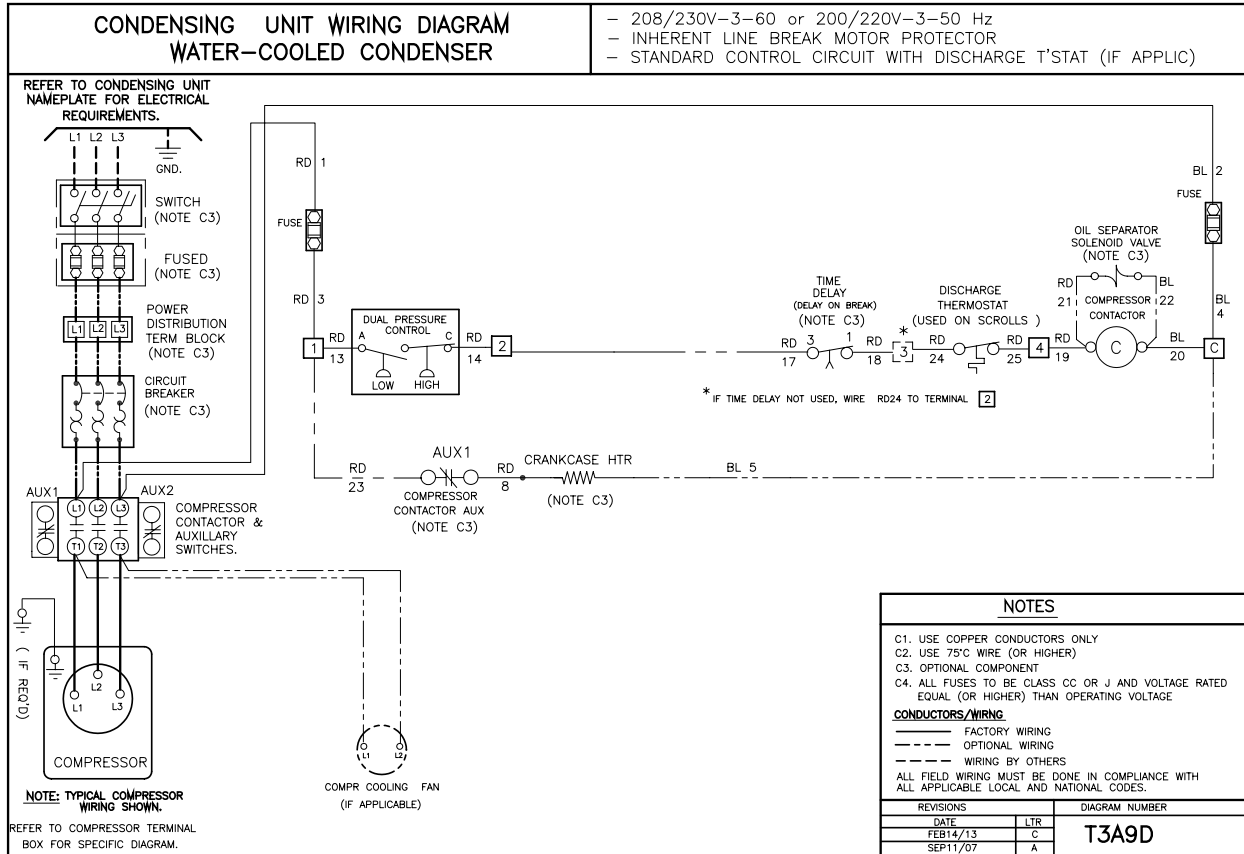

TYPICAL SYSTEM WIRING DIAGRAM

460/3/60 or 575/3/60 Unit

with Single Low Profile Electric Defrost Evaporator

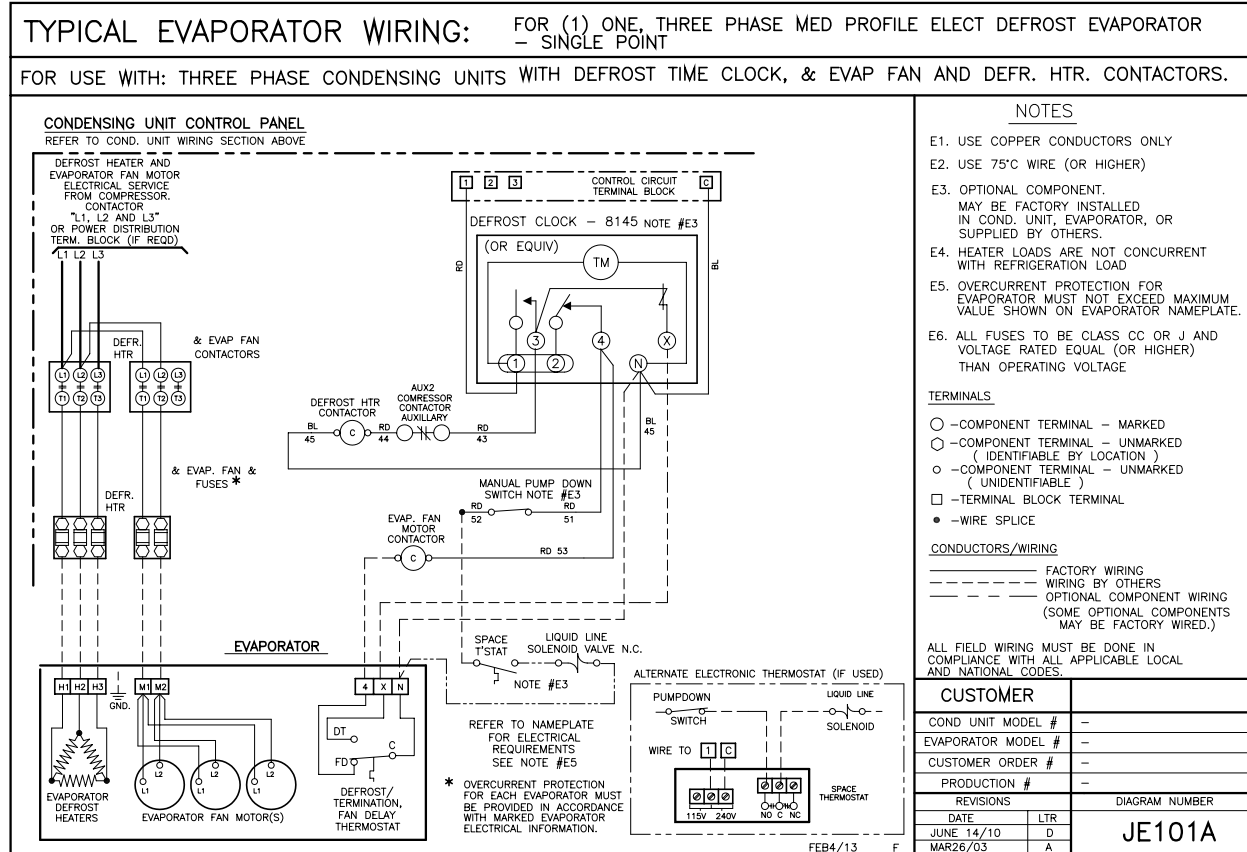
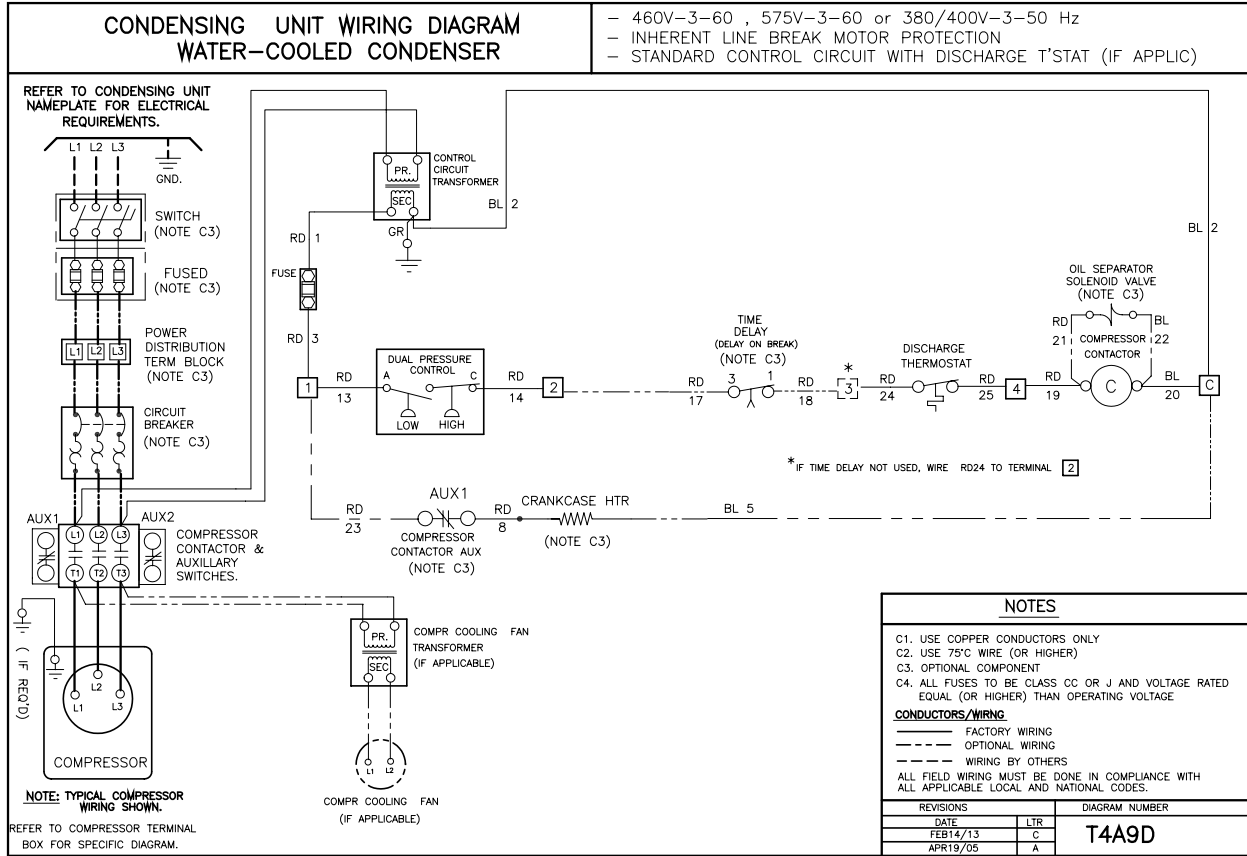

 <p>PRODUCT SUPPORT</p>	<p><i>web:</i> b-rp.ca/bx <i>email:</i> rcu-wccu@b-rp.ca <i>call:</i> 1-844-893-3222 x523</p>
 <p>TROUBLESHOOTING</p>	<p><i>email:</i> troubleshooting@b-rp.ca <i>call:</i> 1-844-893-3222 x529</p>
 <p>SERVICE PARTS</p>	<p><i>web:</i> b-rp.ca/parts <i>email:</i> parts@b-rp.ca <i>call:</i> 1-844-893-3222 x501</p>
 <p>WARRANTY</p>	<p><i>web:</i> b-rp.ca/warranty <i>email:</i> warranty@b-rp.ca <i>call:</i> 1-844-893-3222 x501</p>
 <p>ORDERS</p>	<p><i>email:</i> orders@b-rp.ca <i>call:</i> 1-844-893-3222 x501</p>
 <p>SHIPPING</p>	<p><i>email:</i> shipping@b-rp.ca <i>call:</i> 1-844-893-3222 x503</p>



General Sales, Parts & Service, Manufacturing & Engineering
135 Little Nine Drive, Morehead City, NC 28557
252-240-2829 • 1-800-24-BALLY • FAX: 252-240-0384
e-mail: ballysales@ballyrefboxes.com • www.ballyrefboxes.com



DISTRIBUTED BY:

