



NEXT GENERATION AIR HANDLERS

**INDOOR/OUTDOOR AIR HANDLERS OFFERING UP TO
64,000 CFM WITH UP TO 8" STATIC PRESSURE**



Features

- Single wall heavy gauge galvanized cabinet
- Full size access doors for easy maintenance
- Efficient forward curved blower
- Internal motor
- ETL Certification
- Horizontal and vertical cabinet styles
- External electrical box mounted on cabinet
- Extended grease lines with external access
- Stainless steel drain pan on all cooling coils

Options

- Double wall cabinet with 2" mineral wool insulation
- Outdoor cabinet
- Internal vibration isolators
- Airfoil (up to 8" total static pressure)
- Disconnect switch
- Flat filter
- Angle filters
- Mixing box
- Dampers



NOTHING BEATS A BALLY

BAC, BAH, BAF Air Handlers

Our central station air handling unit has been designed to meet your requirements for air conditioning, heating and ventilation applications. Available in single zone, horizontal or vertical models from 700 to 64,000 CFM, the unit allows design flexibility and higher total static pressures. Consisting of forward curved centrifugal fans housed in a galvanized steel cabinet, the unit features accessories consistent with your application. Galvanized steel insulated cooling coil cabinets are generously sized for direct expansion, chilled or hot water copper tube, aluminum fin coils.

- **Indoor/Outdoor Applications**
- 14 Models
- Up to 6" total static pressure
- Up to 64,000 CFM
- Up to 75 HP

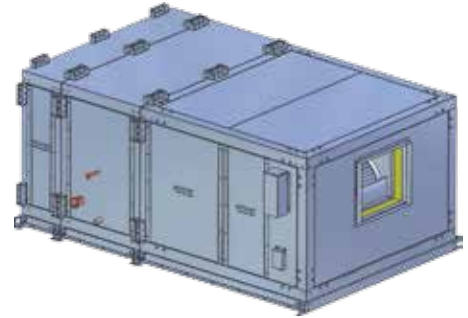

BAP Product Coolers

This flexible unit can be used in any number of applications ranging from low temperature freezers to ripening rooms.

- **Indoor Applications Only**
- Large Face Area Centrifugal Fan
- "Bolt-On" Coil for Maximum Capacity in Minimum Space
- 10 Models
- Up to 44,000 CFM
- Up to 30 HP

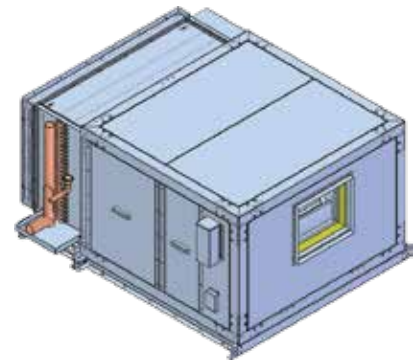

BAB Bolt-On Air Cooled Condenser/Heat Reclaim

The BAB centrifugal air cooled condenser is available as an alternative to roof mounted propeller fan type units. Featuring galvanized steel, dynamically balanced, forward curved fans housed in a galvanized steel cabinet, the BAB is ideal for conditions requiring flexible CFM and varied static pressures. Copper tube, aluminum fin condenser coils in various row and fin configurations make this unit an ideal choice for indoor mounted and ducted applications.

- **Indoor Applications Only**
- Large Face Area Centrifugal Fan
- "Bolt-On" Coil for Maximum Capacity in Minimum Space
- 14 Models
- Up to 55,000 CFM
- Up to 50 HP

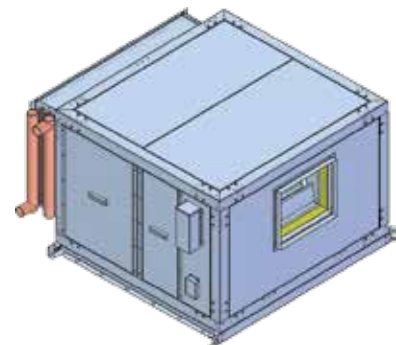

Morehead City, NC | Brantford, ON | Longview, TX
Toll Free: 1-800-242-2559

ballysales@ballyrefboxes.com
www.b-rp.ca